



# **DEEP SEA ELECTRONICS PLC DSE8660 Operator Manual**

**Document number 057-120**

Author : Anthony Manton



Deep Sea Electronics Plc  
Highfield House  
Hunmanby  
North Yorkshire  
YO14 0PH  
ENGLAND

Sales Tel: +44 (0) 1723 890099  
Sales Fax: +44 (0) 1723 893303

E-mail: [sales@deepseapl.com](mailto:sales@deepseapl.com)  
Website: [www.deepseapl.com](http://www.deepseapl.com)

## DSE8660 ATS and Mains Controller Operators Manual

© Deep Sea Electronics Plc

All rights reserved. No part of this publication may be reproduced in any material form (including photocopying or storing in any medium by electronic means or other) without the written permission of the copyright holder except in accordance with the provisions of the Copyright, Designs and Patents Act 1988.

Applications for the copyright holder's written permission to reproduce any part of this publication should be addressed to Deep Sea Electronics Plc at the address above.

The DSE logo is a UK registered trademark of Deep Sea Electronics PLC.

Any reference to trademarked product names used within this publication is owned by their respective companies.

Deep Sea Electronics Plc reserves the right to change the contents of this document without prior notice.

### Amendments since last publication

Issue no.	Comments
1	First release
2	Added ROCOF & Vector Shift and page numbers
3	Added 'MSC OLD UNITS ON BUS' alarm description
4	Added Ethernet, Host USB , Data logging
4.1	Added amendments to multiple mains
5	Added Expansion Devices

### Clarification of notation used within this publication.



Highlights an essential element of a procedure to ensure correctness.



Indicates a procedure or practice, which, if not strictly observed, could result in damage or destruction of equipment.



Indicates a procedure or practice, which could result in injury to personnel or loss of life if not followed correctly.

## TABLE OF CONTENTS

Section	Page
<b>1 BIBLIOGRAPHY .....</b>	<b>6</b>
1.1 INSTALLATION INSTRUCTIONS .....	6
1.2 TRAINING GUIDES .....	6
1.3 MANUALS.....	6
<b>2 INTRODUCTION .....</b>	<b>7</b>
<b>3 SPECIFICATIONS.....</b>	<b>8</b>
3.1 TERMINAL SPECIFICATION .....	8
3.2 POWER SUPPLY REQUIREMENTS .....	8
3.3 GENERATOR BUS AND MAINS VOLTAGE / FREQUENCY SENSING .....	8
3.4 MAINS AND LOAD CURRENT SENSING .....	9
3.5 INPUTS .....	9
3.5.1 DIGITAL INPUTS .....	9
3.6 OUTPUTS .....	10
3.6.1 OUTPUTS A & B.....	10
3.6.2 OUTPUTS C & D .....	10
3.6.3 OUTPUTS E,F,G,H,I & J.....	10
3.7 COMMUNICATION PORTS .....	11
3.7.1 USB CONNECTION .....	12
3.7.2 USB HOST-MASTER (USB DRIVE CONNECTION) .....	12
3.7.3 RS232 .....	13
3.7.4 RS485 .....	15
3.7.5 ETHERNET .....	16
3.7.5.1 DIRECT PC CONNECTION .....	16
3.7.5.2 CONNECTION TO BASIC ETHERNET.....	17
3.7.5.3 CONNECTION TO COMPANY INFRASTRUCTURE ETHERNET .....	18
3.7.5.4 CONNECTION TO THE INTERNET .....	19
3.8 DSENET® FOR EXPANSION MODULES .....	22
3.9 SOUNDER .....	23
3.9.1 ADDING AN EXTERNAL SOUNDER TO THE APPLICATION .....	23
3.10 DIMENSIONS AND MOUNTING .....	24
3.10.1 DIMENSIONS .....	24
3.10.2 CABLE TIE FIXING POINTS .....	26
3.10.3 SILICON SEALING GASKET.....	26
3.11 APPLICABLE STANDARDS.....	27
3.11.1 ENCLOSURE CLASSIFICATIONS.....	28
<b>4 INSTALLATION.....</b>	<b>30</b>
4.1 TERMINAL DESCRIPTION .....	30
4.1.1 DC SUPPLY, FUEL AND START OUTPUTS.....	30
4.1.2 MAGNETIC PICKUP, CAN AND EXPANSION .....	31
4.1.3 LOAD SWITCHING AND MAINS VOLTAGE SENSING (V1) .....	32
4.1.4 GENERATOR BUS VOLTAGE SENSING (V2).....	32
4.1.5 MAINS CURRENT TRANSFORMERS.....	33
4.1.1 LOAD CURRENT TRANSFORMER.....	34
4.1.1.1 ADVANTAGES OF LOAD CT.....	34
4.1.2 CONFIGURABLE DIGITAL INPUTS .....	35
4.1.3 PC CONFIGURATION INTERFACE CONNECTOR.....	35
4.1.4 RS485 CONNECTOR.....	36
4.1.5 RS232 CONNECTOR.....	36
4.2 TYPICAL WIRING DIAGRAMS .....	37
4.2.1 3 PHASE, 4 WIRE .....	38
4.2.2 SINGLE MAINS, MULTIPLE GENERATORS.....	39
4.2.3 DUAL MAINS, MULTIPLE GENERATORS .....	40
4.2.4 MULTIPLE MAINS, MULTIPLE GENERATORS .....	41
4.2.5 DSENET®.....	42
4.2.6 EARTH SYSTEMS.....	43

4.2.6.1	NEGATIVE EARTH.....	43
4.2.6.2	POSITIVE EARTH.....	43
4.2.6.3	FLOATING EARTH.....	43
<b>4.3</b>	<b>TYPICAL ARRANGEMENT OF DSENET®.....</b>	<b>44</b>
<b>5</b>	<b>DESCRIPTION OF CONTROLS.....</b>	<b>45</b>
5.1	DSE8660 AMF CONTROL MODULE.....	45
5.2	QUICKSTART GUIDE.....	47
5.2.1	STARTING THE ENGINE(S).....	47
5.2.2	STOPPING THE ENGINE(S).....	48
5.3	VIEWING THE INSTRUMENT PAGES.....	49
5.3.1	STATUS.....	50
5.3.2	MAINS.....	51
5.3.3	BUS.....	51
5.3.4	SERIAL PORT.....	52
5.3.5	ABOUT.....	56
5.3.5.1	ETHERNET PAGES.....	56
5.3.5.2	DATA LOGGING PAGES.....	57
5.4	VIEWING THE EVENT LOG.....	58
5.5	USER CONFIGURABLE INDICATORS.....	59
5.6	CONTROLS.....	60
<b>6</b>	<b>OPERATION.....</b>	<b>62</b>
6.1	ALTERNATIVE CONFIGURATIONS.....	62
6.2	STOP MODE.....	63
6.3	AUTOMATIC MODE.....	63
6.3.1	WAITING IN AUTO MODE.....	63
6.3.2	STARTING SEQUENCE.....	63
6.3.3	ENGINE RUNNING.....	64
6.3.3.1	BUS MODE.....	64
6.3.3.2	MAINS MODE.....	64
6.3.4	STOPPING SEQUENCE.....	64
6.4	MANUAL MODE.....	65
6.4.1	WAITING IN MANUAL MODE.....	65
6.4.2	ENGINE RUNNING.....	65
6.4.3	STOPPING SEQUENCE.....	65
6.5	TEST MODE.....	66
6.5.1	WAITING IN TEST MODE.....	66
6.5.2	ENGINE RUNNING.....	66
6.6	MULTIPLE MAINS OPERATION.....	67
6.6.1	8660 PRIORITY.....	67
6.6.2	8660 LOAD CT.....	68
<b>7</b>	<b>PROTECTIONS.....</b>	<b>69</b>
7.1	INDICATIONS.....	69
7.2	WARNINGS.....	70
7.3	ELECTRICAL TRIPS.....	71
7.4	ROCOF / VECTOR SHIFT.....	71
<b>8</b>	<b>SCHEDULER.....</b>	<b>72</b>
8.1.1	STOP MODE.....	72
8.1.2	MANUAL MODE.....	72
8.1.3	AUTO MODE.....	72
<b>9</b>	<b>FRONT PANEL CONFIGURATION.....</b>	<b>73</b>
9.1	ACCESSING THE MAIN FRONT PANEL CONFIGURATION EDITOR.....	74
9.1.1	EDITING A PARAMETER.....	75
9.1.2	ADJUSTABLE PARAMETERS.....	76
9.2	ACCESSING THE 'RUNNING' CONFIGURATION EDITOR.....	77
9.2.1	EDITING A PARAMETER.....	77
9.2.2	ADJUSTABLE PARAMETERS (RUNNING EDITOR).....	77
<b>10</b>	<b>COMMISSIONING.....</b>	<b>78</b>
10.1.1	PRE-COMMISSIONING.....	78

<b>11</b>	<b>FAULT FINDING .....</b>	<b>79</b>
<b>12</b>	<b>MAINTENANCE, SPARES, REPAIR AND SERVICING .....</b>	<b>80</b>
12.1.1.1	PACK OF PLUGS .....	80
12.1.1.2	INDIVIDUAL PLUGS.....	80
<b>12.2</b>	<b>PURCHASING ADDITIONAL FIXING CLIPS FROM DSE .....</b>	<b>80</b>
<b>12.3</b>	<b>PURCHASING ADDITIONAL SEALING GASKET FROM DSE.....</b>	<b>80</b>
<b>12.4</b>	<b>EXPANSION MODULES.....</b>	<b>81</b>
<b>13</b>	<b>WARRANTY .....</b>	<b>82</b>
<b>14</b>	<b>DISPOSAL.....</b>	<b>82</b>
14.1	WEEE (WASTE ELECTRICAL AND ELECTRONIC EQUIPMENT) .....	82
14.2	ROHS (RESTRICTION OF HAZARDOUS SUBSTANCES).....	82

# 1 BIBLIOGRAPHY

This document refers to and is referred to by the following DSE publications which can be obtained from the DSE website [www.deepseapl.com](http://www.deepseapl.com)

## 1.1 INSTALLATION INSTRUCTIONS

Installation instructions are supplied with the product in the box and are intended as a 'quick start' guide only.

DSE PART	DESCRIPTION
053-069	DSE8610 Installation Instructions
053-070	DSE8660 Installation Instructions
053-032	DSE2548 LED Expansion Annunciator Installation Instructions
053-033	DSE2130 Input Expansion Installation Instructions
053-034	DSE2157 Output Expansion Installation Instructions

## 1.2 TRAINING GUIDES

Training Guides are produced to give 'handout' sheets on specific subjects during training sessions.

DSE PART	DESCRIPTION
056-005	Using CTs With DSE Products
056-007	Advantages of Load CT
056-021	Mains Decoupling
056-022	Breaker Control
056-030	Module PIN Codes
056-042	Bus Mode or Mains Mode
056-047	Fail to close and out of sync

## 1.3 MANUALS

DSE PART	DESCRIPTION
057-082	DSE2130 Input Expansion Manual
057-083	DSE2157 Output Expansion Manual
057-084	DSE2548 Annunciator Expansion Manual
057-115	DSE8610 Operator Manual
057-119	DSE8600 Series Configuration Software Manual
057-139	DSE2131 Input Expansion Manual
057-140	DSE2133 Input Expansion Manual
057-141	DSE2152 Output Expansion Manual

## 2 INTRODUCTION

This document details the installation and operation requirements of the DSE8660 modules, part of the DSEPower® range of products.

The manual forms part of the product and should be kept for the entire life of the product. If the product is passed or supplied to another party, ensure that this document is passed to them for reference purposes.

This is not a *controlled document*. You will not be automatically informed of updates. Any future updates of this document will be included on the DSE website at [www.deepseapl.com](http://www.deepseapl.com)

The **DSE8600 series** is designed to provide differing levels of functionality across a common platform. This allows the generator OEM greater flexibility in the choice of controller to use for a specific application.

The **DSE8660** module has been designed to monitor the mains (utility) supply and automatically start/stop one or more generator sets equipped with DSE8610 controllers depending upon the status of the mains (utility) supply.

Synchronising and Load Sharing features are included within the controller, along with the necessary protections for such a system. This provides forward sync, back sync (no break changeover) and start/stop upon changing load levels.

The user also has the facility to view the system operating parameters via the LCD display.

The powerful ARM microprocessor contained within the module allows for incorporation of a range of complex features:

- *Text based LCD display (supporting multiple languages).*
- **True RMS** Voltage, Current and Power monitoring.
- *Fully configurable inputs for use as alarms or a range of different functions.*
- *R.O.C.O.F. and Vector shift for detection of mains failure when in parallel with the mains supply.*

Using a PC and the Configuration Suite software allows alteration of selected operational sequences, timers and alarms.

Additionally, the module's integral fascia configuration editor allows adjustment of a subset of this information. A robust plastic case designed for front panel mounting houses the module. Connections are via locking plug and sockets.

### 3 SPECIFICATIONS

#### 3.1 TERMINAL SPECIFICATION

Connection type	Two part connector. <ul style="list-style-type: none"> <li>• Male part fitted to module</li> <li>• Female part supplied in module packing case - Screw terminal, rising clamp, no internal spring.</li> </ul>	 <p>Example showing cable entry and screw terminals of a 10 way connector</p>
Minimum cable size	0.5mm <sup>2</sup> (AWG 24)	
Maximum cable size	2.5mm <sup>2</sup> (AWG 10)	

**NOTE:** For purchasing additional connector plugs from DSE, please see the section entitled *Maintenance, Spares, Repair and Servicing* elsewhere in this document.

#### 3.2 POWER SUPPLY REQUIREMENTS

Minimum supply voltage	8V continuous
Cranking dropouts	Able to survive 0V for 50mS providing the supply was at least 10V before the dropout and recovers to 5V afterwards. This is more than sufficient to allow the module to operate during engine cranking where the battery supply falls as low as 4V (on a 12V system!)  This is achieved without the need for internal batteries or other external requirements.
Maximum supply voltage	35V continuous (60V protection for surges)
Reverse polarity protection	-35V continuous
Maximum operating current (all inputs and outputs on)	400mA at 24V 200mA at 12V
Maximum standby current (all inputs and outputs off)	110mA at 24V 210mA at 12V

##### Plant supply instrumentation display

Range	0V-70V DC (Note Maximum continuous operating voltage of 35V DC)
Resolution	0.1V
Accuracy	±1% full scale (±0.7V)

#### 3.3 GENERATOR BUS AND MAINS VOLTAGE / FREQUENCY SENSING

Measurement type	True RMS conversion
Sample Rate	5KHz or better
Harmonics	Up to 10 <sup>th</sup> or better
Input Impedance	300K Ω ph-N
Phase to Neutral	15V (minimum required for sensing frequency) to 333V AC (absolute maximum) Suitable for 110V to 277V nominal (±20% for under/overvoltage detection)
Phase to Phase	26V (minimum required for sensing frequency) to 576V AC (absolute maximum) Suitable for 190V ph-ph to 479V ph-ph nominal (±20% for under/overvoltage detection)
Common mode offset from Earth	100V AC (max)
Resolution	1V AC phase to neutral 2V AC phase to phase
Accuracy	±1% of full scale phase to neutral (±3.33V ph-N) ±2% of full scale phase to phase (±11.52V ph-ph)
Minimum frequency	3.5Hz
Maximum frequency	75.0Hz
Frequency resolution	0.1Hz
Frequency accuracy	±0.2Hz



### 3.4 MAINS AND LOAD CURRENT SENSING

Measurement type	True RMS conversion
Sample Rate	5KHz or better
Harmonics	Up to 10 <sup>th</sup> or better
Nominal CT secondary rating	1A or 5A (5A recommended)
Maximum continuous current	5A
Overload Measurement	3 x Nominal CT setting
Absolute maximum overload	50A for 1 second
Burden	0.5VA (0.02Ω current shunts)
common mode offset	±2V peak plant ground to CT common terminal
Resolution	0.5% of 5A
Accuracy	±1% of Nominal (1A or 5A) (excluding CT error)

### 3.5 INPUTS

#### 3.5.1 DIGITAL INPUTS

Number	11
Arrangement	Contact between terminal and ground
Low level threshold	2.1V minimum
High level threshold	6.6V maximum
Maximum input voltage	+50V DC with respect to plant supply negative
Minimum input voltage	-24V DC with respect to plant supply negative
Contact wetting current	7mA typical
Open circuit voltage	12V typical

### 3.6 OUTPUTS

#### 3.6.1 OUTPUTS A & B

Outputs A & B are not fitted to the DSE8660 controller.

#### 3.6.2 OUTPUTS C & D

Type	Voltage free relays, fully configurable, normally used for generator bus / mains load switch control.
Rating	8A resistive @ 250 V AC

#### 3.6.3 OUTPUTS E,F,G,H,I & J

Type	Fully configurable, supplied from DC supply terminal 2.
Rating	3A resistive @ 35V

### 3.7 COMMUNICATION PORTS

USB Port	USB2.0 Device for connection to PC running DSE configuration suite only Max distance 6m (20 feet)
Serial Communication	RS232 and RS485 are both fitted for individual or simultaneous operation.
RS232 Serial port	Non – Isolated port Max Baud rate 115200 baud subject to S/W TX, RX, RTS, CTS, DSR, DTR, DCD Male 9 way D type connector Max distance 15m (50 feet)
RS485 Serial port	Isolated Data connection 2 wire + common Half Duplex Data direction control for Transmit (by s/w protocol) Max Baud Rate 115200 External termination required (120Ω) Max common mode offset 70V (on board protection transorb) Max distance 1.2km (¾ mile)
MSC Port	MSC Port for connection to other DSE8660 and DSE8610 controllers Max distance 240m (133 feet). Use DSE124 to extend this if required.

### 3.7.1 USB CONNECTION

The USB port is provided to give a simple means of connection between a PC and the DSE8660 series controller. Using the DSE Configuration Suite Software, the operator is then able to control the module, starting or stopping the generator(s), selecting operating modes, etc. Additionally, the various operating parameters (such as output volts, oil pressure, etc.) of the remote generator(s) are available to be viewed or changed.

To connect a DSE8600 series module to a PC by USB, the following items are required:

- DSE8600 series module
- DSE 8600 series configuration software (Supplied on configuration suite software CD or available from [www.deepseapl.com](http://www.deepseapl.com)).
- USB cable Type A to Type B.  
(This is the same cable as often used between a PC and a USB printer)  
  
DSE can supply this cable if required :  
PC Configuration interface lead (USB type A – type B) DSE Part No 016-125



**NOTE:** - The DC supply must be connected to the module for configuration by PC.

**NOTE:** - Refer to DSE8600 series Configuration Suite Manual (DSE part 057-119) for further details on configuring, monitoring and control.

### 3.7.2 USB HOST-MASTER (USB DRIVE CONNECTION)

Capability to add USB Host facility for USB 'Pendrive' type interface for data recording  
Connector Type A.  
For data logging max maximum size 16Gb.(see viewing the instrument pages)

**NOTE:-** Refer to DSE8600 series Configuration Suite Manual (DSE part 057-119) for further details on configuring, monitoring and control.

### 3.7.3 RS232

The RS232 port on the DSE8600 series controller supports the Modbus RTU protocol. The Gencomm register table for the controller is available upon request from the DSE Technical Support Department.

RS232 is for short distance communication (max 15m) and is typically used to connect the DSE86xx series controller to a telephone or GSM modem for more remote communications.

Many PCs are not fitted with an internal RS232 serial port. DSE DOES NOT recommends the use of USB to RS232 convertors but can recommend PC add-ons to provide the computer with an RS232 port.

Recommended PC Serial Port add-ons (for computers without internal RS232 port):  
Remember to check these parts are suitable for your PC. Consult your PC supplier for further advice.

- Brainboxes PM143 PCMCIA RS232 card (for laptop PCs)
- Brainboxes VX-001 Express Card RS232 (for laptops and nettops PCs)
- Brainboxes UC246 PCI RS232 card (for desktop PCs)
- Brainboxes PX-246 PCI Express 1 Port RS232 1 x 9 Pin (for desktop PCs)



Supplier:

**Brainboxes**

**Tel:** +44 (0)151 220 2500

**Web:** <http://www.brainboxes.com>

**Email:** Sales:[sales@brainboxes.com](mailto:sales@brainboxes.com)

**NB** DSE Have no business tie to Brainboxes. Over many years, our own engineers have used these products and are happy to recommend them.

**RECOMMENDED EXTERNAL MODEMS:**

- Multitech Global Modem – MultiModem ZBA (PSTN)  
DSE Part Number 020-252  
(Contact DSE Sales for details of localisation kits for these modems)



- Wavecom Fastrak Supreme GSM modem kit (PSU, Antenna and modem)\*  
DSE Part number 0830-001-01



- Brodersen GSM Industrial Modem\*  
DSE Part number 020-245



**NOTE: \*For GSM modems, a SIM card is required, supplied by your GSM network provider:**

- For SMS only, a 'normal' voice SIM card is required. This enables the controller to send SMS messages to designated mobile phones upon status and alarm conditions.
- For a data connection to a PC running DSE Configuration Suite Software, a 'special' CSD (Circuit Switched Data) SIM card is required that will enable the modem to answer an incoming data call. Many 'pay as you go' services will not provide a CSD (Circuit Switched Data) SIM card.

### 3.7.4 RS485

The RS485 port on the DSE8600 series controller supports the Modbus RTU protocol. The DSE Gencomm register table for the controller is available upon request from the DSE Technical Support Department.

RS485 is used for point-to-point cable connection of more than one device (maximum 32 devices) and allows for connection to PCs, PLCs and Building Management Systems (to name just a few devices).

One advantage of the RS485 interface is the large distance specification (1.2km when using Belden 9841 (or equivalent) cable). This allows for a large distance between the DSE8600 series module and a PC running the DSE Configuration Suite software. The operator is then able to control the module, starting or stopping the generator(s), selecting operating modes, etc.

The various operating parameters (such as output volts, oil pressure, etc.) of the remote generator(s) can be viewed or changed.

**NOTE: - For a single module to PC connection and distances up to 6m (8yds), the USB connection method is more suitable and provides for a lower cost alternative to RS485 (which is more suited to longer distance connections).**

Recommended PC Serial Port add-ons (for computers without internal RS485 port). Remember to check these parts are suitable for your PC. Consult your PC supplier for further advice.

- Brainboxes PM154 PCMCIA RS485 card (for laptops PCs)  
Set to 'Half Duplex, Autogating" with 'CTS True' set to 'enabled'
- Brainboxes VX-023 ExpressCard 1 Port RS422/485 (for laptops and nettop PCs)
- Brainboxes UC320 PCI Velocity RS485 card (for desktop PCs)  
Set to 'Half Duplex, Autogating" with 'CTS True' set to 'enabled'
- Brainboxes PX-324 PCI Express 1 Port RS422/485 (for desktop PCs)



Supplier:

**Brainboxes**

**Tel:** +44 (0)151 220 2500

**Web:** <http://www.brainboxes.com>

**Email:** Sales:[sales@brainboxes.com](mailto:sales@brainboxes.com)

**NB** DSE Have no business tie to Brainboxes. Over many years, our own engineers have used these products and are happy to recommend them.

### 3.7.5 ETHERNET

The DSE8660 is fitted with ETHERNET socket for connection to LAN (local area networks)

Description	
1	TX+
2	TX-
3	RX+
4	Do not connect
5	Do not connect
6	RX-
7	Do not connect
8	Do not connect

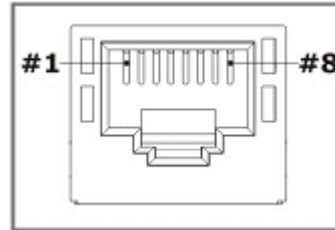

#### 3.7.5.1 DIRECT PC CONNECTION

##### Requirements

- DSE8660
- Crossover Ethernet cable (see Below)
- PC with Ethernet port

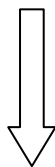











Crossover network cable





**Crossover cable wiring detail**

Two pairs crossed, two pairs uncrossed  
10baseT/100baseTX crossover

Pin	Connection 1 (T568A)	Connection 2 (T568B)
1	 white/green stripe	 white/orange stripe
2	 green solid	 orange solid
3	 white/orange stripe	 white/green stripe
4	 blue solid	 blue solid
5	 white/blue stripe	 white/blue stripe
6	 orange solid	 green solid
7	 white/brown stripe	 white/brown stripe
8	 brown solid	 brown solid

For the advanced Engineer, a crossover cable is a CAT5 cable with one end terminated as T568A and the other end terminated as T568B.



**NOTE:-** This cable can be purchased from any good PC or IT store.

**3.7.5.2 CONNECTION TO BASIC ETHERNET**

**Requirements**

- DSE8660
- Ethernet cable (see below)
- Working Ethernet (company or home network)
- PC with Ethernet port

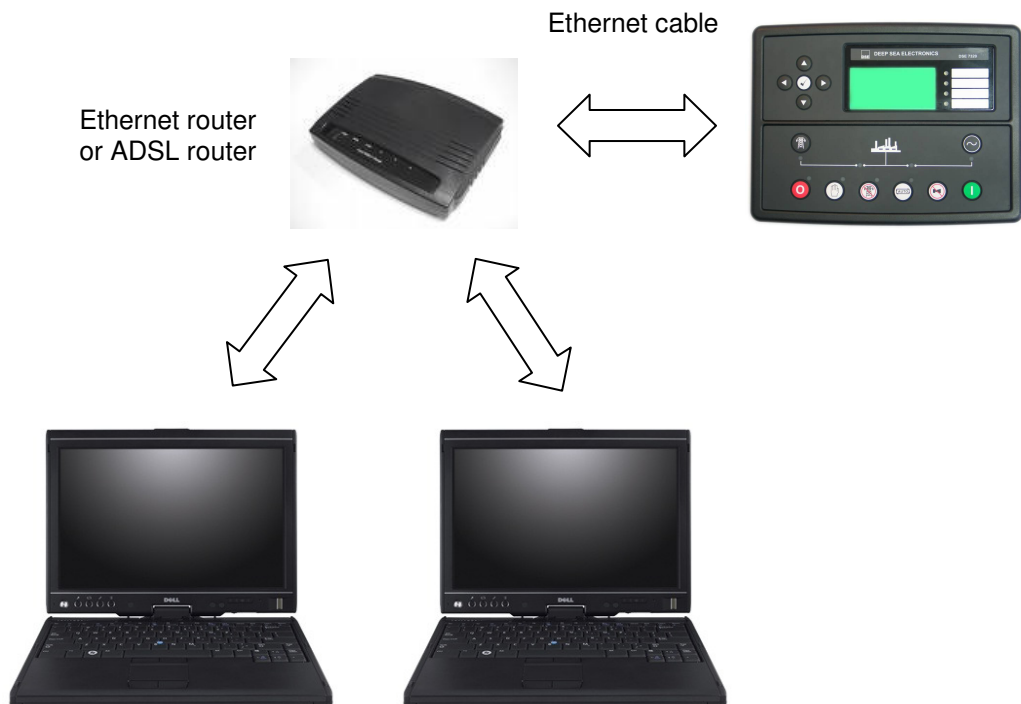

**Ethernet cable wiring detail**

10baseT/100baseT

Pin	Connection 1 (T568A)	Connection 2 (T568A)
1	 white/green stripe	 white/green stripe
2	 green solid	 green solid
3	 white/orange stripe	 white/orange stripe
4	 blue solid	 blue solid
5	 white/blue stripe	 white/blue stripe
6	 orange solid	 orange solid
7	 white/brown stripe	 white/brown stripe
8	 brown solid	 brown solid



For the advanced Engineer, this cable has both ends terminated as T568A (as shown below) or T568B.

**NOTE:- DSE Stock a 2m (2.2yds) Ethernet Cable – Part number 016-137. Alternatively they can be purchased from any good PC or IT store.**

**3.7.5.3 CONNECTION TO COMPANY INFRASTRUCTURE ETHERNET**

**Requirements**

- DSE8660
- Ethernet cable (see below)
- Working Ethernet (company or home network)
- PC with Ethernet port and Windows Internet Explorer 6 or above, Firefox

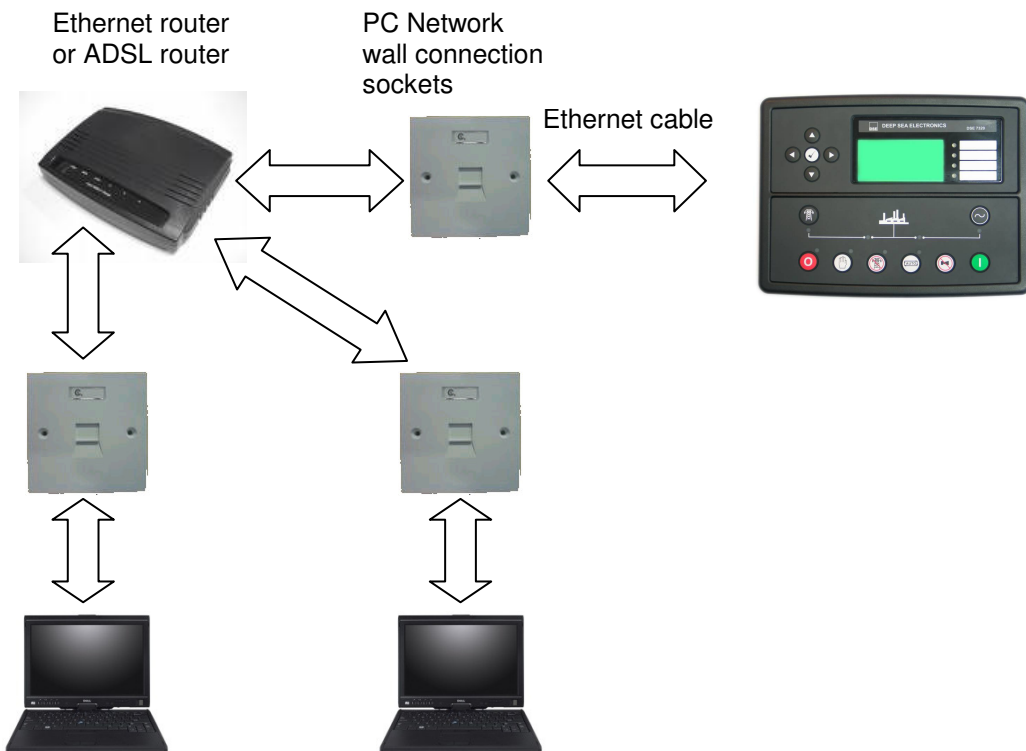

**Ethernet cable wiring detail**

10baseT/100baseT

Pin	Connection 1 (T568A)	Connection 2 (T568A)
1	 white/green stripe	 white/green stripe
2	 green solid	 green solid
3	 white/orange stripe	 white/orange stripe
4	 blue solid	 blue solid
5	 white/blue stripe	 white/blue stripe
6	 orange solid	 orange solid
7	 white/brown stripe	 white/brown stripe
8	 brown solid	 brown solid

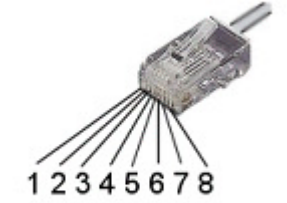

For the advanced Engineer, this cable has both ends terminated as T568A (as shown below) or T568B.

**NOTE:-** DSE Stock a 2m (2.2yds) Ethernet Cable – Part number 016-137. Alternatively they can be purchased from any good PC or IT store.

**3.7.5.4 CONNECTION TO THE INTERNET**



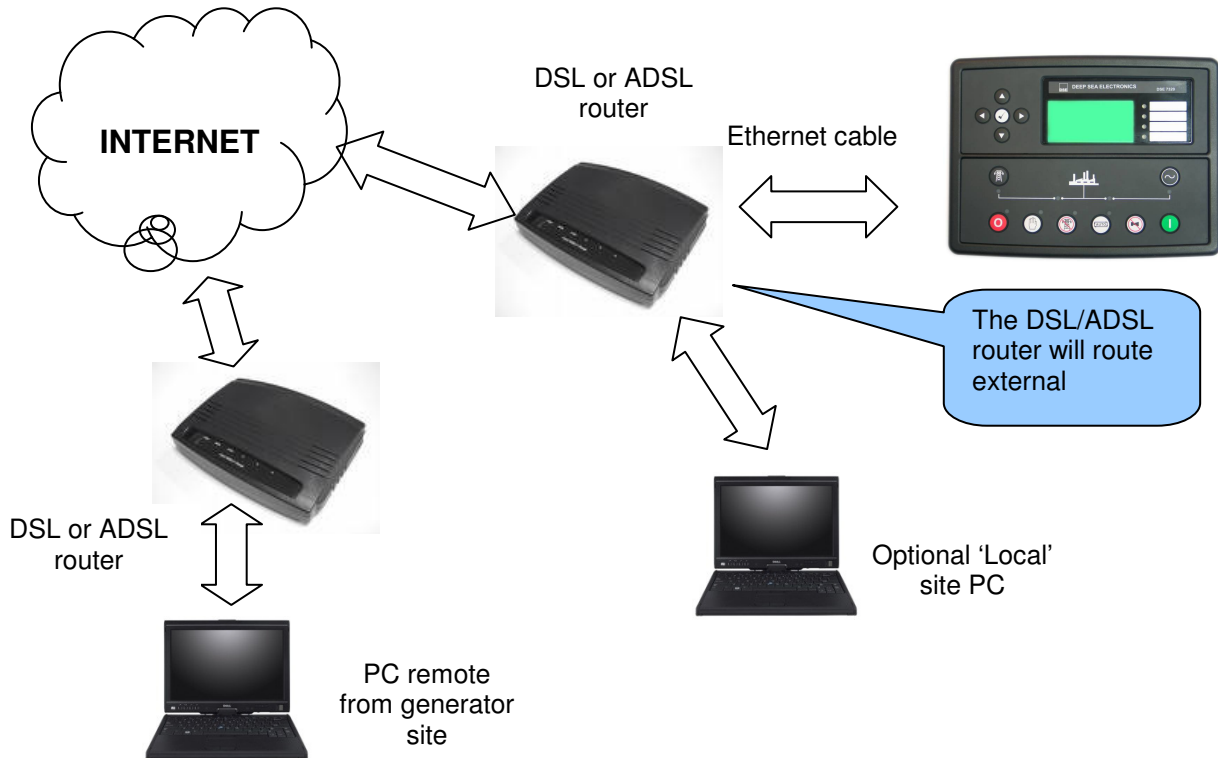

**Requirements**

- Ethernet cable (see below)
- Working Ethernet (company or home network)
- Working Internet connection (ADSL or DSL recommended)



**Ethernet cable wiring detail**

10baseT/100baseT

Pin	Connection 1 (T568A)	Connection 2 (T568A)
1	 white/green stripe	 white/green stripe
2	 green solid	 green solid
3	 white/orange stripe	 white/orange stripe
4	 blue solid	 blue solid
5	 white/blue stripe	 white/blue stripe
6	 orange solid	 orange solid
7	 white/brown stripe	 white/brown stripe
8	 brown solid	 brown solid



For the advanced Engineer, this cable has both ends terminated as T568A (as shown below) or T568B.

**NOTE:- DSE Stock a 2m (2.2yds) Ethernet Cable – Part number 016-137. Alternatively they can be purchased from any good PC or IT store.**

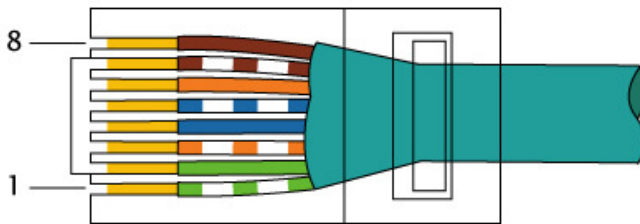

EIA/TIA-568A

## **Firewall configuration for internet access**

As modem/routers differ enormously in their configuration, it is not possible for DSE to give a complete guide to their use with the DSE8660. However it is possible to give a description of the requirements in generic terms. For details of how to achieve the connection to your modem/router you are referred to the supplier of your modem/router equipment.

The DSE8660 makes its data available over Modbus TCP and as such communicates over the Ethernet using a Port configured via the DSE config suite software..

You must configure your modem/router to allow inbound traffic on this port. For more information you are referred to your WAN interface device (modem/router) manufacturer.

It is also important to note that if the port assigned (setting from software "Modbus Port Number") is already in use on the LAN, the DSE8660 cannot be used and another port must be used .

### **Outgoing Firewall rule**

As the DSE8660 makes its user interface available to standard web browsers, all communication uses the chosen port. It is usual for a firewall to make the same port outgoing open for communication.

### **Incoming traffic (virtual server)**

Network Address and Port Translation (NAPT) allows a single device, such as the modem/router gateway, to act as an agent between the Internet (or "public external network") and a local (or "internal private") network. This means that only a single, unique IP address is required to represent an entire group of computers.

For our DSE8660 application, this means that the WAN IP address of the modem/router is the IP address we need to access the site from an external (internet) location.

When requests reaches the modem/router, we want this passed to a 'virtual server' for handling, in our case this is the DSE8660 module.

**Result :** Traffic arriving from the WAN (internet) on port xxx is automatically sent to IP address set within the configuration software on the LAN (DSE8660) for handling.

 <b>NOTE:- Refer to DSE8600 series Configuration Suite Manual (DSE part 057-119) for further details on configuring, monitoring and control.</b>
---

### 3.8 DSENET® FOR EXPANSION MODULES

DSENet® is the interconnection cable between the host controller and the expansion module(s) and must not be connect to any device other than DSE equipment designed for connection to the DSENet®

Cable type	Two core screened twisted pair
Cable characteristic impedance	120Ω
Recommended cable	Belden 9841 Belden 9271
Maximum cable length	1200m (¾ mile) when using Belden 9841 or direct equivalent. 600m (666 yds) when using Belden 9271 or direct equivalent.
DSENet® topology	"Daisy Chain" Bus with no stubs (spurs)
DSENet® termination	120Ω. Fitted internally to host controller. Must be fitted externally to the 'last' expansion module by the customer.

**▲NOTE: As a termination resistor is internally fitted to the host controller, the host controller must be the 'first' unit on the DSENet®. A termination resistor MUST be fitted to the 'last' unit on the DSENet®. For connection details, you are referred to the section entitled 'typical wiring diagram' elsewhere in this document.**

**▲NOTE: DSE8600 series do not support the 2510/2520 display modules.**

### 3.9 SOUNDER

DSE8600 Series features an internal sounder to draw attention to warning, shutdown and electrical trip alarms.

Sounder level	64db @ 1m
---------------	-----------

#### 3.9.1 ADDING AN EXTERNAL SOUNDER TO THE APPLICATION

Should an external alarm or indicator be required, this can be achieved by using the DSE Configuration Suite PC software to configure an auxiliary output for *Audible Alarm*, and by configuring an auxiliary input for *Alarm Mute* (if required).

The audible alarm output activates and de-activates at the same time as the module's internal sounder. The Alarm mute input and internal alarm mute button activate 'in parallel' with each other. Either signal will mute both the internal sounder and audible alarm output.

Example of configuration to achieve external sounder with external alarm mute button:

The screenshot shows two configuration panels from the DSE Configuration Suite software. The top panel, titled "Relay Outputs (DC Supply Out)", has a table with two columns: "Source" and "Polarity". The "Source" column has a dropdown menu with "Audible Alarm" selected. The "Polarity" column has a dropdown menu with "Energise" selected. The bottom panel, titled "Digital Input A", has a "Function" dropdown menu with "Alarm Mute" selected.

Output	Source	Polarity
Output E	Audible Alarm	Energise

Function
Alarm Mute

Specifications

**3.10 DIMENSIONS AND MOUNTING**

**3.10.1 DIMENSIONS**

240.0mm x 181.1mm x 41.7mm (9.4" x 7.1" x 1.6")

**PANEL CUTOUT**

220mm x 160mm (8.7" x 6.3")

**WEIGHT**

0.7kg (1.4lb)

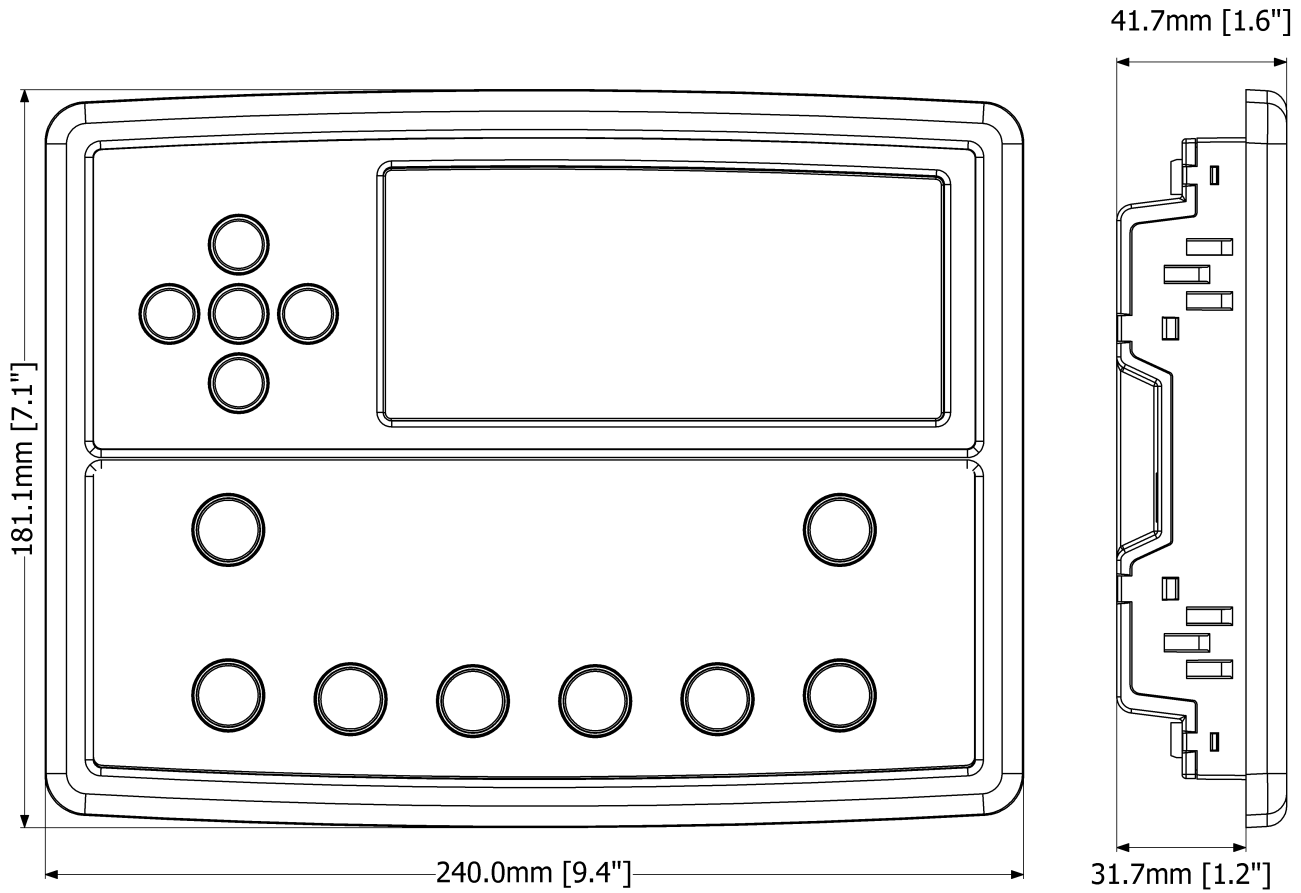



## FIXING CLIPS

Supplied fixing clips hold the module into the panel fascia.

Withdraw the fixing clip screw (turn anticlockwise) until only the pointed end is protruding from the clip.

- Insert the three 'prongs' of the fixing clip into the slots in the side of the 8600 series module case.
- Pull the fixing clip backwards (towards the back of the module) ensuring all three prongs of the clip are inside their allotted slots.
- Turn the fixing clip screws clockwise until they make contact with the panel fascia.
- Turn the screws a little more to secure the module into the panel fascia. Take care not to over tighten the fixing clip screws.

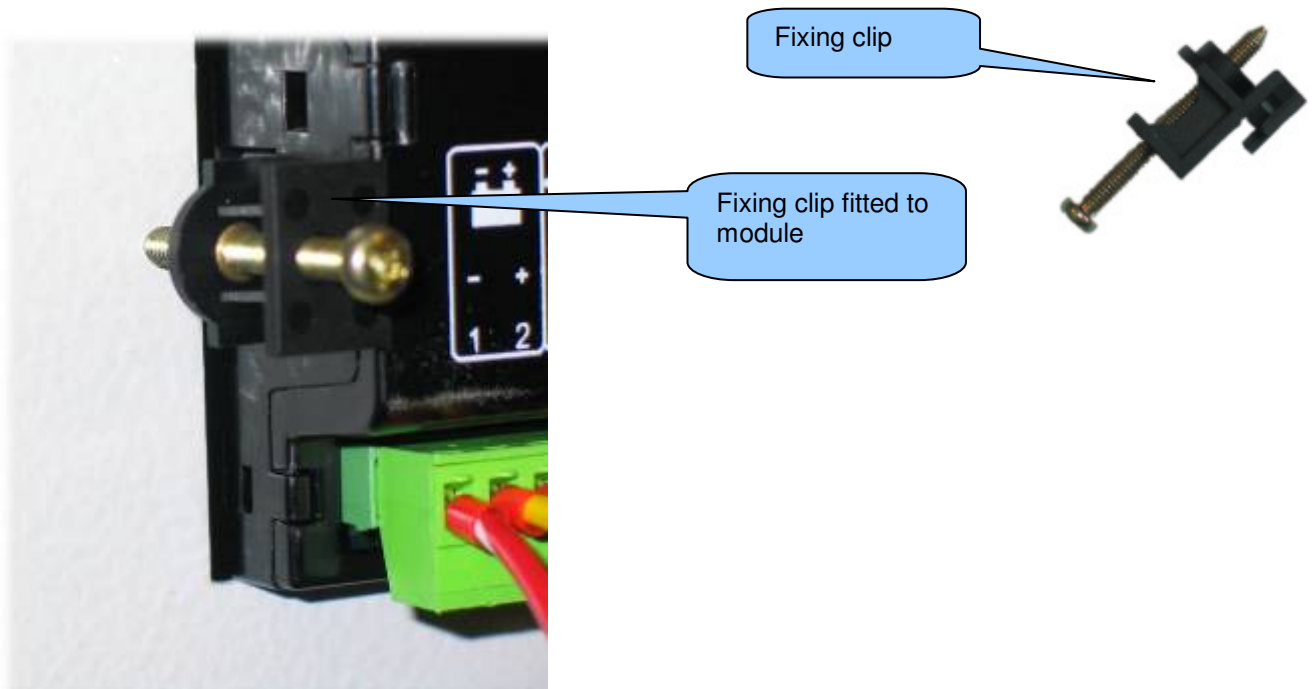

**NOTE: In conditions of excessive vibration, mount the module on suitable anti-vibration mountings.**

### 3.10.2 CABLE TIE FIXING POINTS

Integral cable tie fixing points are included on the rear of the module's case to aid wiring. This additionally provides strain relief to the cable loom by removing the weight of the loom from the screw connectors, thus reducing the chance of future connection failures.

Care should be taken not to overtighten the cable tie (for instance with cable tie tools) to prevent the risk of damage to the module case.



Cable tie fixing point

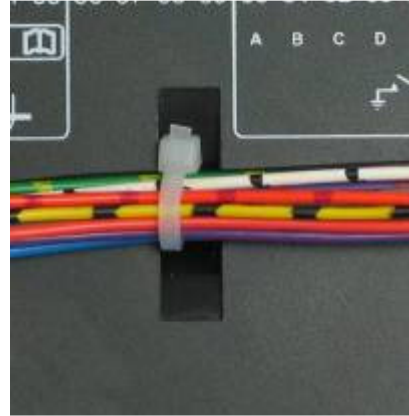

With cable and tie in place

### 3.10.3 SILICON SEALING GASKET

The supplied silicon gasket provides improved sealing between the 8600 series module and the panel fascia. The gasket is fitted to the module before installation into the panel fascia.

Take care to ensure the gasket is correctly fitted to the module to maintain the integrity of the seal.

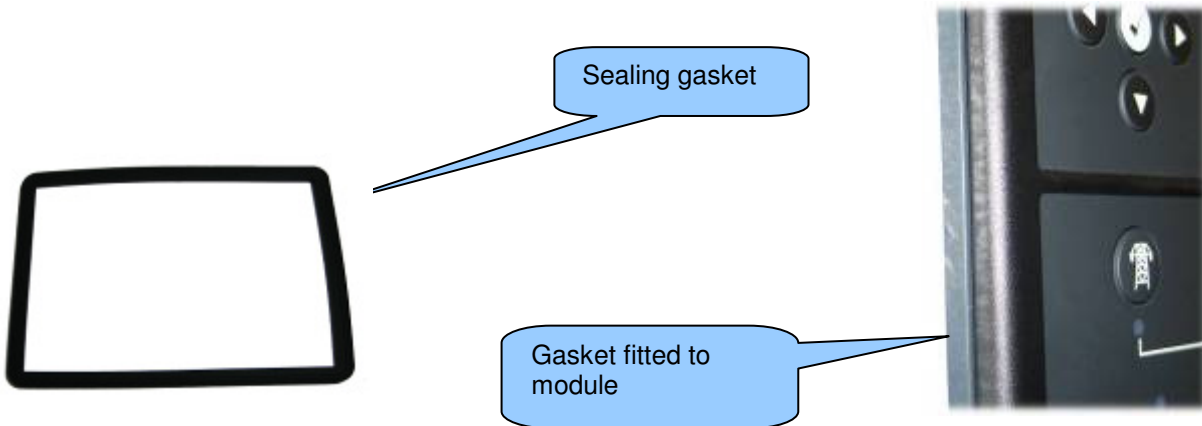

### 3.11 APPLICABLE STANDARDS

<b>BS 4884-1</b>	This document conforms to BS4884-1 1992 Specification for presentation of essential information.
<b>BS 4884-2</b>	This document conforms to BS4884-2 1993 Guide to content
<b>BS 4884-3</b>	This document conforms to BS4884-3 1993 Guide to presentation
<b>BS EN 60068-2-1</b> (Minimum temperature)	-30°C (-22°F)
<b>BS EN 60068-2-2</b> (Maximum temperature)	+70°C (158°F)
<b>BS EN 60950</b>	Safety of information technology equipment, including electrical business equipment
<b>BS EN 61000-6-2</b>	EMC Generic Immunity Standard (Industrial)
<b>BS EN 61000-6-4</b>	EMC Generic Emission Standard (Industrial)
<b>BS EN 60529</b> (Degrees of protection provided by enclosures) (see overleaf)	IP65 (front of module when installed into the control panel with the supplied sealing gasket) IP42 (front of module when installed into the control panel WITHOUT being sealed to the panel)
<b>UL508</b> <b>NEMA rating</b> (Approximate) (see overleaf)	12 (Front of module when installed into the control panel with the supplied sealing gasket). 2 (Front of module when installed into the control panel WITHOUT being sealed to the panel)
<b>IEEE C37.2</b> (Standard Electrical Power System Device Function Numbers and Contact Designations)	<p>Under the scope of IEEE 37.2, <i>function numbers can also be used to represent functions in microprocessor devices and software programs.</i></p> <p>The 8600 series controller is device number 11L-8600 (Multifunction device protecting Line (mains) – 8600 series module).</p> <p>As the module is configurable by the generator OEM, the functions covered by the module will vary. Under the module's factory configuration, the device numbers included within the module are :</p> <p>2 – Time delay starting or closing relay 27AC – AC undervoltage relay 27DC – DC undervoltage relay 30 – annunciator relay 42 – Running circuit breaker 52 – AC circuit breaker 59AC – AC overvoltage relay 59DC – DC overvoltage relay 62 – Time delay stopping or opening relay 74– Alarm relay 81 – Frequency relay 86 – Lockout relay</p>

In line with our policy of continual development, Deep Sea Electronics, reserve the right to change specification without notice.

### 3.11.1 ENCLOSURE CLASSIFICATIONS

#### IP CLASSIFICATIONS

8600 series specification under BS EN 60529 Degrees of protection provided by enclosures

**IP65** (Front of module when module is installed into the control panel with the optional sealing gasket).

**IP42** (front of module when module is installed into the control panel WITHOUT being sealed to the panel)

First Digit	Second Digit
Protection against contact and ingress of solid objects 0 No protection	Protection against ingress of water 0 No protection
1 Protected against ingress solid objects with a diameter of more than 50 mm. No protection against deliberate access, e.g. with a hand, but large surfaces of the body are prevented from approach.	1 Protection against dripping water falling vertically. No harmful effect must be produced (vertically falling drops).
2 Protected against penetration by solid objects with a diameter of more than 12 mm. Fingers or similar objects prevented from approach.	2 Protection against dripping water falling vertically. There must be no harmful effect when the equipment (enclosure) is tilted at an angle up to 15° from its normal position (drops falling at an angle).
3 Protected against ingress of solid objects with a diameter of more than 2.5 mm. Tools, wires etc. with a thickness of more than 2.5 mm are prevented from approach.	3 Protection against water falling at any angle up to 60° from the vertical. There must be no harmful effect (spray water).
4 Protected against ingress of solid objects with a diameter of more than 1 mm. Tools, wires etc. with a thickness of more than 1 mm are prevented from approach.	4 Protection against water splashed against the equipment (enclosure) from any direction. There must be no harmful effect (splashing water).
5 Protected against harmful dust deposits. Ingress of dust is not totally prevented but the dust must not enter in sufficient quantity to interface with satisfactory operation of the equipment. Complete protection against contact.	5 Protection against water projected from a nozzle against the equipment (enclosure) from any direction. There must be no harmful effect (water jet).
6 Protection against ingress of dust (dust tight). Complete protection against contact.	6 Protection against heavy seas or powerful water jets. Water must not enter the equipment (enclosure) in harmful quantities (splashing over).

**NEMA CLASSIFICATIONS**

8600 series NEMA Rating (Approximate)

**12** (Front of module when module is installed into the control panel with the optional sealing gasket).

**2** (front of module when module is installed into the control panel WITHOUT being sealed to the panel)



**NOTE: - There is no direct equivalence between IP / NEMA ratings. IP figures shown are approximate only.**







1 <b>IP30</b>	Provides a degree of protection against contact with the enclosure equipment and against a limited amount of falling dirt.
2 <b>IP31</b>	Provides a degree of protection against limited amounts of falling water and dirt.
3 <b>IP64</b>	Provides a degree of protection against windblown dust, rain and sleet; undamaged by the formation of ice on the enclosure.
3R <b>IP32</b>	Provides a degree of protection against rain and sleet.; undamaged by the formation of ice on the enclosure.
4 (X) <b>IP66</b>	Provides a degree of protection against splashing water, windblown dust and rain, hose directed water; undamaged by the formation of ice on the enclosure. (Resist corrosion).
12/12K <b>IP65</b>	Provides a degree of protection against dust, falling dirt and dripping non corrosive liquids.
13 <b>IP65</b>	Provides a degree of protection against dust and spraying of water, oil and non corrosive coolants.

## 4 INSTALLATION

The DSE8600 Series module is designed to be mounted on the panel fascia. For dimension and mounting details, see the section entitled *Specification, Dimension and mounting* elsewhere in this document.



### 4.1 TERMINAL DESCRIPTION

#### 4.1.1 DC SUPPLY, FUEL AND START OUTPUTS

Icon	PIN No	DESCRIPTION	CABLE SIZE	NOTES
	1	DC Plant Supply Input (Negative)	2.5mm <sup>2</sup> AWG 13	
	2	DC Plant Supply Input (Positive)	2.5 mm <sup>2</sup> AWG 13	(Recommended Maximum Fuse 15A anti-surge) Supplies the module (2A anti-surge requirement) and Output relays E,F,G & H
	3	Not Connected		
	4	Not Connected		
	5	Not Connected		
	6	Not Connected		
	7	Functional Earth	2.5mm <sup>2</sup> AWG 13	Connect to a good clean earth point.
	8	Output relay E	1.0mm <sup>2</sup> AWG 18	Plant Supply Positive from terminal 2. 3 Amp rated.
	9	Output relay F	1.0mm <sup>2</sup> AWG 18	Plant Supply Positive from terminal 2. 3 Amp rated.
	10	Output relay G	1.0mm <sup>2</sup> AWG 18	Plant Supply Positive. from terminal 2. 3 Amp rated.
	11	Output relay H	1.0mm <sup>2</sup> AWG 18	Plant Supply Positive from terminal 2. 3 Amp rated.
	12	Output relay I	1.0mm <sup>2</sup> AWG 18	Plant Supply Positive from terminal 2. 3 Amp rated.
	13	Output relay J	1.0mm <sup>2</sup> AWG 18	Plant Supply Positive from terminal 2. 3 Amp rated.



 **NOTE: Terminal 14 is not fitted to the DSE8600 series controller.**

### 4.1.2 MAGNETIC PICKUP, CAN AND EXPANSION

	PIN No	DESCRIPTION	CABLE SIZE	NOTES
	22	Not Connected		
	23	Not Connected		
	24	Not Connected		
<b>CAN</b> 	25	Not Connected		
	26	Not Connected		
	27	Not Connected		
	28	DSENet expansion +	0.5mm <sup>2</sup> AWG 20	Use only 120Ω RS485 approved cable
	29	DSENet expansion -	0.5mm <sup>2</sup> AWG 20	Use only 120Ω RS485 approved cable
	30	DSENet expansion SCR	0.5mm <sup>2</sup> AWG 20	Use only 120Ω RS485 approved cable
<b>MSC</b>	31	MultiSet Comms (MSC) Link H	0.5mm <sup>2</sup> AWG 20	Use only 120Ω RS485 approved cable
	32	MultiSet Comms (MSC) Link L	0.5mm <sup>2</sup> AWG 20	Use only 120Ω RS485 approved cable
	33	MultiSet Comms (MSC) Link SCR	0.5mm <sup>2</sup> AWG 20	Use only 120Ω RS485 approved cable
<b>GOV</b>	34	Not Connected		
	35	Not Connected		
<b>AVR</b>	37	Not Connected		
	38	Not Connected		

 **NOTE: Screened 120Ω impedance cable specified for use with CAN must be used for the DSENet link and the Multiset comms (MSC) link. DSE stock and supply Belden cable 9841 which is a high quality 120Ω impedance cable suitable for CAN use (DSE part number 016-030)**

### 4.1.3 LOAD SWITCHING AND MAINS VOLTAGE SENSING (V1)

	PIN No	DESCRIPTION	CABLE SIZE	NOTES
	39	Output relay C	1.0mm AWG 18	Normally configured to control load switching device (Recommend 10A fuse)
	40	Output relay C	1.0mm AWG 18	Normally configured to control load switching device
	41	Output relay D	1.0mm AWG 18	Normally configured to control load switching device (Recommend 10A fuse)
	42	Output relay D	1.0mm AWG 18	Normally configured to control load switching device
V1	43	Mains L1 (R) voltage monitoring	1.0mm AWG 18	Connect to Mains L1 (R) incoming supply (AC) (Recommend 2A fuse)
	44	Mains L2 (S) voltage monitoring	1.0mm AWG 18	Connect to Mains L1 (S) incoming supply (AC) (Recommend 2A fuse)
	45	Mains L3 (T) voltage monitoring	1.0mm AWG 18	Connect to Mains L1 (T) incoming supply (AC) (Recommend 2A fuse)
	46	Mains Neutral (N) input	1.0mm AWG 18	Connect to Mains N incoming supply (AC)

**NOTE:** - The above table describes connections to a three phase, four-wire system. For alternative wiring topologies, please see the ALTERNATIVE AC TOPOLOGIES section of this manual.

### 4.1.4 GENERATOR BUS VOLTAGE SENSING (V2)

	PIN No	DESCRIPTION	CABLE SIZE	NOTES
V2	47	Generator Bus L1 (U) voltage monitoring	1.0mm <sup>2</sup> AWG 18	Connect to Generator Bus L1 (U) output (AC) (Recommend 2A fuse)
	48	Generator Bus L2 (V) voltage monitoring input	1.0mm <sup>2</sup> AWG 18	Connect to Generator Bus L2 (V) output (AC) (Recommend 2A fuse)
	49	Generator Bus L3 (W) voltage monitoring input	1.0mm <sup>2</sup> AWG 18	Connect to Generator Bus L3 (W) output (AC) (Recommend 2A fuse)
	50	Generator Bus Neutral (N) input	1.0mm <sup>2</sup> AWG 18	Connect to Generator Bus Neutral terminal (AC)

**NOTE:** The above table describes connections to a three phase, four wire system. For alternative wiring topologies, please see the ALTERNATIVE AC TOPOLOGIES section of this manual.



### 4.1.5 MAINS CURRENT TRANSFORMERS

**⚠ WARNING!** - Do not disconnect this plug when the CTs are carrying current. Disconnection will open circuit the secondary of the C.T.'s and dangerous voltages may then develop. Always ensure the CTs are not carrying current and the CTs are short circuit connected before making or breaking connections to the module.

**⚠ NOTE:** - The 8600 series module has a burden of 0.5VA on the CT. Ensure the CT is rated for the burden of the 8600 series controller, the cable length being used and any other equipment sharing the CT. If in doubt, consult your CT supplier.

**⚠ NOTE:** - Take care to ensure correct polarity of the CT primary as shown below. If in doubt, check with the CT supplier.

#### CT LABELLING

p1,  $\kappa$  or K is the primary of the CT that 'points' towards the MAINS

p2,  $\ell$  or L is the primary of the CT that 'points' towards the LOAD

s1 is the secondary of the CT that connects to the DSE Module's input for the CT measuring (I1,I2,I3)

s2 is the secondary of the CT that should be commoned with the s2 connections of all the other CTs and connected to the CT common terminal of the DSE8600 series modules.

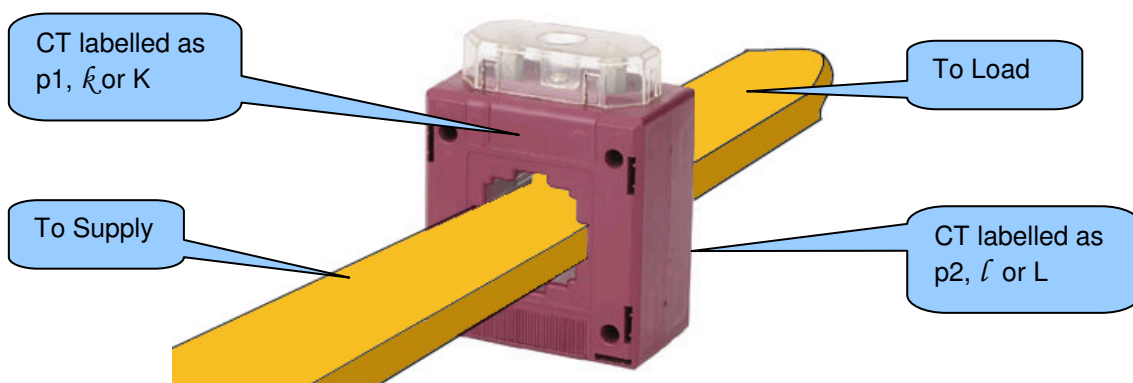



PIN No	DESCRIPTION	CABLE SIZE	NOTES	
	51	CT Secondary for Mains L1	2.5mm <sup>2</sup> AWG 13	Connect to s1 secondary of L1 monitoring CT
	52	CT Secondary for Mains L2	2.5mm <sup>2</sup> AWG 13	Connect to s1 secondary of L2 monitoring CT
	53	CT Secondary for Mains L3	2.5mm <sup>2</sup> AWG 13	Connect to s1 secondary of L3 monitoring CT
	54	DO NOT CONNECT		
	55	Common for CTs connected to L1,L2,L3 (s2)	2.5mm <sup>2</sup> AWG 13	Connect to s2 secondary of L1,L2,L3 monitoring CTs

**⚠ NOTE:** Take care to ensure correct polarity of the CT primary as shown overleaf. If in doubt, check with the CT supplier.

#### 4.1.1 LOAD CURRENT TRANSFORMER

 **WARNING!** - Do not disconnect this plug when the CT is carrying current. Disconnection will open circuit the secondary of the C.T. and dangerous voltages may then develop. Always ensure the CT is not carrying current and the CT is short circuit connected before making or breaking connections to the module.

 **NOTE:** - Load CT is NOT REQUIRED in a system including only one mains supply (with one 8660 controller). See section below detailing advantages of the load CT in a multiple mains (multiple 8660) system.

 **NOTE:** - The 8600 series module has a burden of 0.5VA on the CT. Ensure the CT is rated for the burden of the 8600 series controller, the cable length used and any other equipment sharing the CT. If in doubt, consult your CT supplier.

 **NOTE:** - Take care to ensure correct polarity of the CT primary as shown below. If in doubt, check with the CT supplier.

	Pin No	Description	CABLE SIZE	NOTES
	56	CT Secondary for Load CT	2.5mm <sup>2</sup> AWG 13	Connect to s1 secondary of Load CT
	57	CT Secondary for Load CT	2.5mm <sup>2</sup> AWG 13	Connect to s2 secondary of Load CT

 **NOTE:** - Take care to ensure correct polarity of the CT primary as shown in the previous section. If in doubt, check with the CT supplier.

##### 4.1.1.1 ADVANTAGES OF LOAD CT

The load CT is only required when there is **more than one** DSE8660 on the same system.

When the load CT is fitted the 8660 transfers the right amount of load to the mains before disconnecting the generator(s), preventing them from being shock loaded.



Without the load CT, the 8660 does not know how much load to transfer to the mains when other 8660's are still in island mode. The 8660 would transfer a pre-determined amount of load before disconnecting the generator(s) from the mains. This would lead to there being too much load or not enough load transferred, and the generator(s) would be shock loaded as the generator(s) disconnect from the mains.

### 4.1.2 CONFIGURABLE DIGITAL INPUTS

PIN No	DESCRIPTION	CABLE SIZE	NOTES
60	Configurable digital input A	0.5mm <sup>2</sup> AWG 20	Switch to negative
61	Configurable digital input B	0.5mm <sup>2</sup> AWG 20	Switch to negative
62	Configurable digital input C	0.5mm <sup>2</sup> AWG 20	Switch to negative
63	Configurable digital input D	0.5mm <sup>2</sup> AWG 20	Switch to negative
64	Configurable digital input E	0.5mm <sup>2</sup> AWG 20	Switch to negative
65	Configurable digital input F	0.5mm <sup>2</sup> AWG 20	Switch to negative
66	Configurable digital input G	0.5mm <sup>2</sup> AWG 20	Switch to negative
67	Configurable digital input H	0.5mm <sup>2</sup> AWG 20	Switch to negative
68	Configurable digital input I	0.5mm <sup>2</sup> AWG 20	Switch to negative
69	Configurable digital input J	0.5mm <sup>2</sup> AWG 20	Switch to negative
70	Configurable digital input K	0.5mm <sup>2</sup> AWG 20	Switch to negative

### 4.1.3 PC CONFIGURATION INTERFACE CONNECTOR

This configuration cable is the same as normally used between a PC and a USB printer!

DESCRIPTION	CABLE SIZE	NOTES
 <p>Socket for connection to PC with 86xx series PC software.</p>	0.5mm <sup>2</sup> AWG 20	<p>This is a standard USB type A to type B connector.</p> 

**NOTE:** The USB connection cable between the PC and the DSE8600 series module must not extend beyond 5m (5yds). For distances over 5m, it is possible to use a third party USB extender. Typically, they extend USB up to 50m (yds). The supply and support of this type of equipment is outside the scope of Deep Sea Electronics PLC.

**CAUTION!** Care must be taken not to overload the PC's USB system by connecting more than the recommended number of USB devices to the PC. For further information, consult your PC supplier.

**CAUTION!** This socket must not be used for any other purpose.

#### 4.1.4 RS485 CONNECTOR

PIN No	NOTES
<b>A</b>	Two core screened twisted pair cable. 120Ω impedance suitable for RS485 use.
<b>B</b>	Recommended cable type - Belden 9841
<b>SCR</b>	Max distance 1200m (1.2km) when using Belden 9841 or direct equivalent.

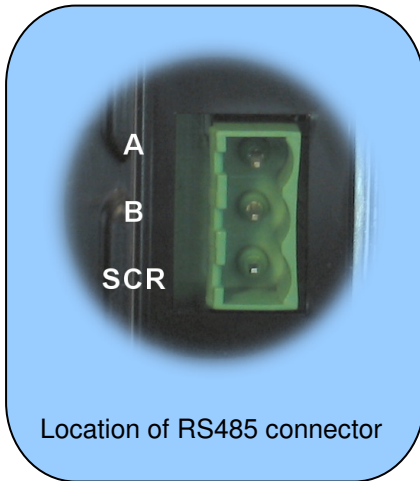

#### 4.1.5 RS232 CONNECTOR

PIN No	NOTES
1	Received Line Signal Detector (Data Carrier Detect)
2	Received Data
3	Transmit Data
4	Data Terminal Ready
5	Signal Ground
6	Data Set Ready
7	Request To Send
8	Clear To Send
9	Ring Indicator

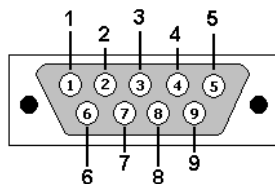

View looking into the male connector on the 8600 series module

## 4.2 TYPICAL WIRING DIAGRAMS

As every system has different requirements, these diagrams show only a TYPICAL system and do not intend to show a complete system.

Genset manufacturers and panel builders may use these diagrams as a starting point; however, you are referred to the completed system diagram provided by your system manufacturer for complete wiring detail.

Further wiring suggestions are available in the following DSE publications, available at [www.deepseapl.com](http://www.deepseapl.com) to website members.

DSE PART	DESCRIPTION
056-022	Breaker Control (Training guide)

4.2.1 3 PHASE, 4 WIRE

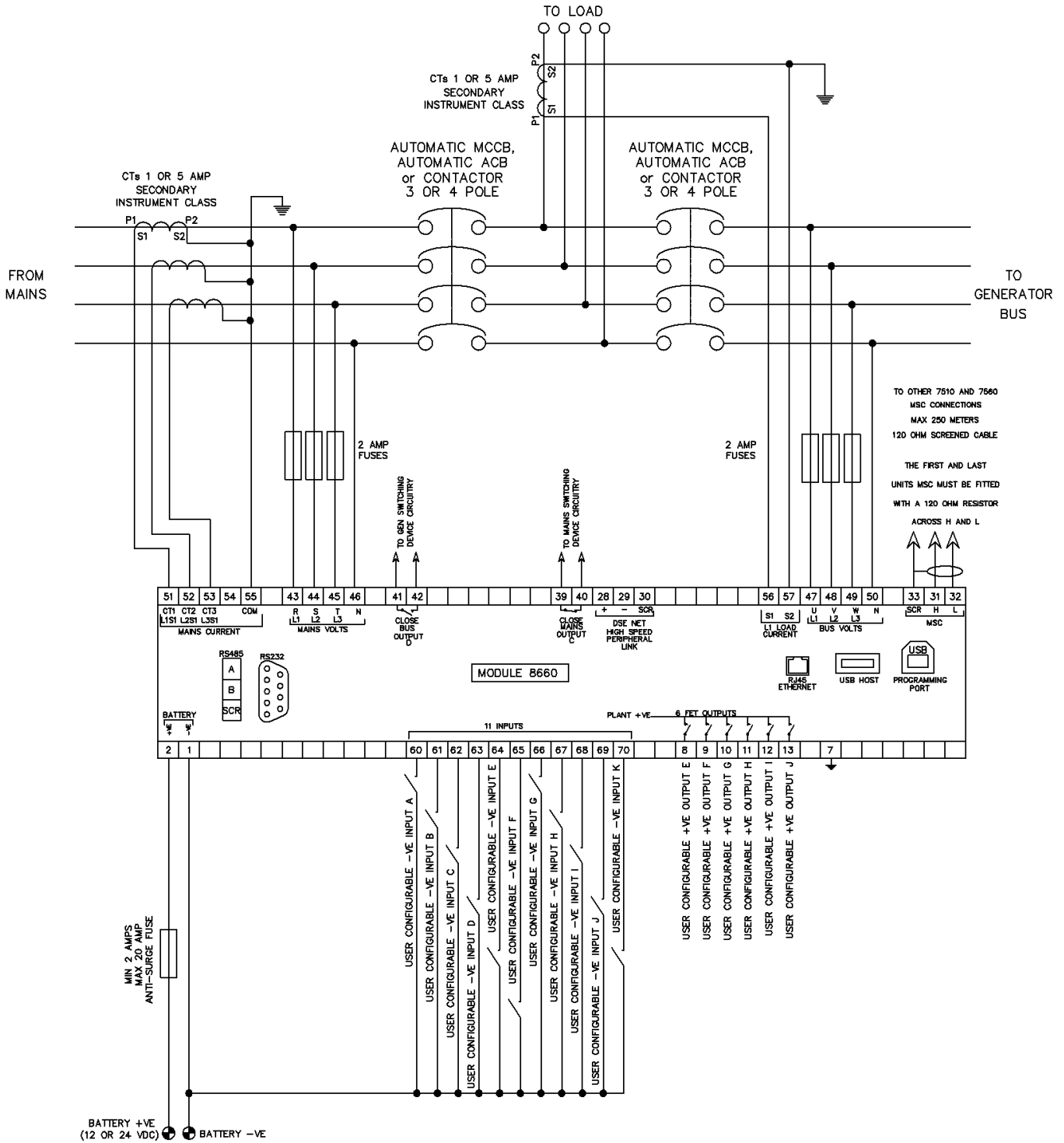

### 4.2.2 SINGLE MAINS, MULTIPLE GENERATORS

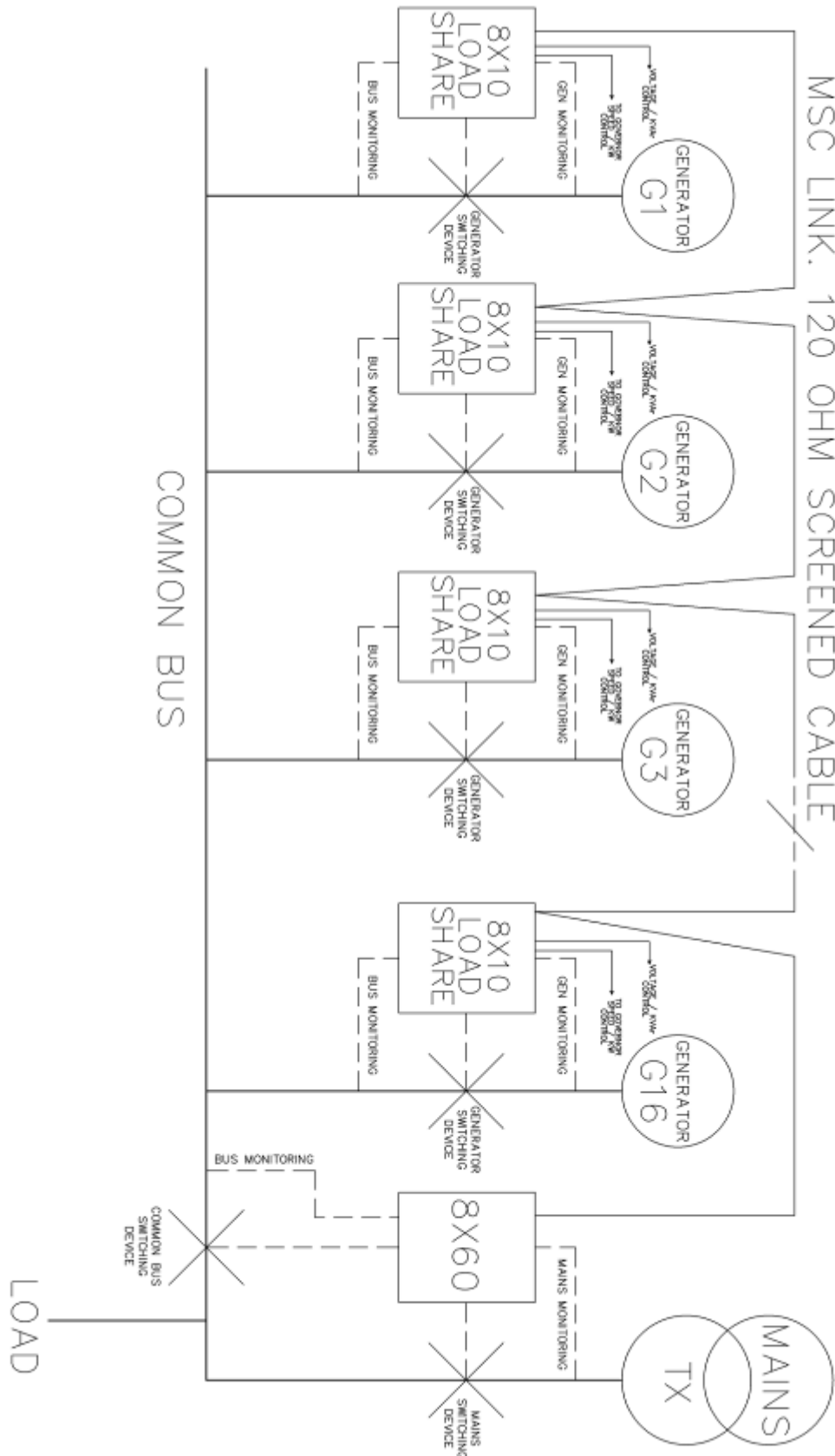

### 4.2.3 DUAL MAINS, MULTIPLE GENERATORS

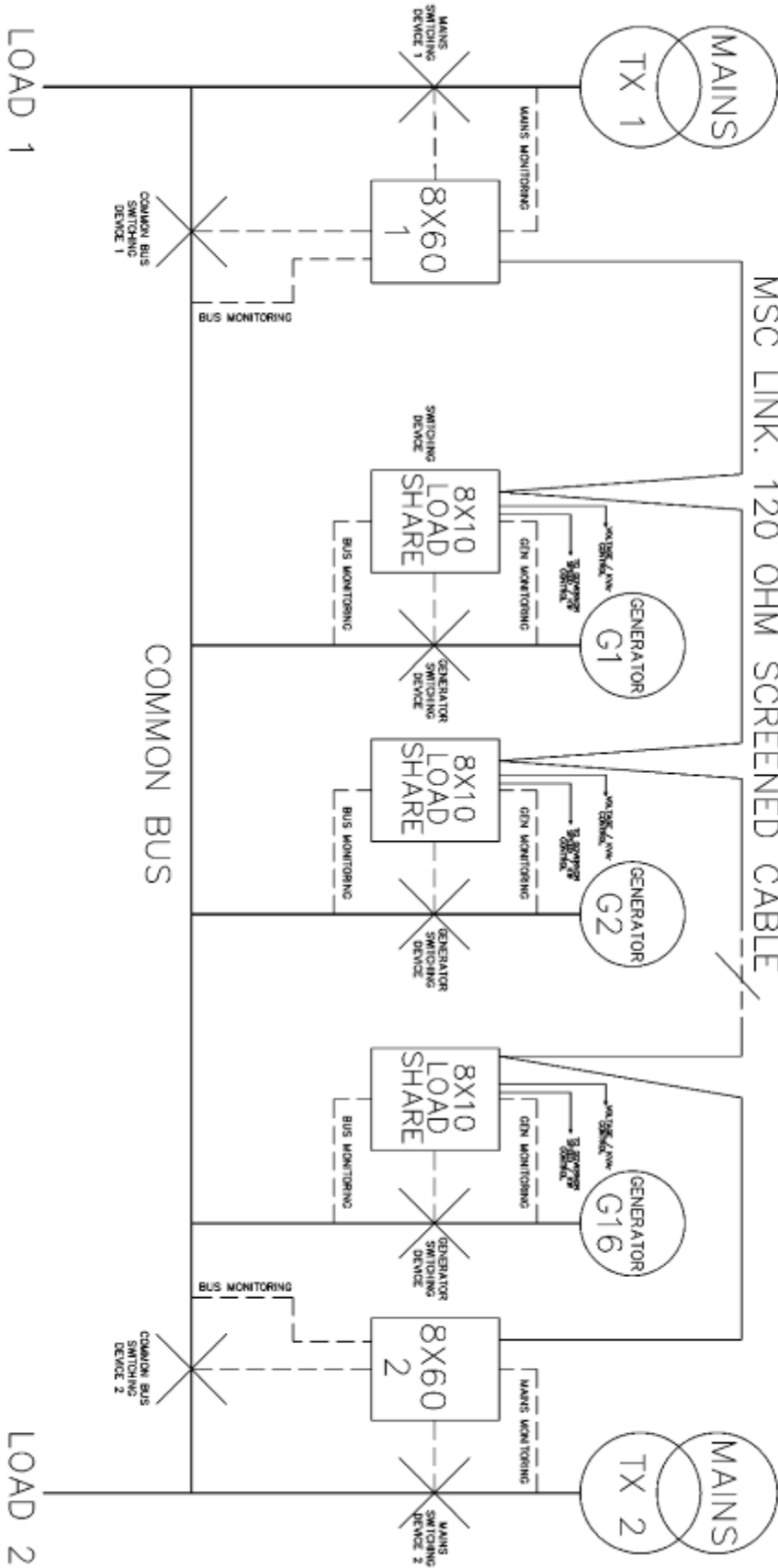



### 4.2.4 MULTIPLE MAINS, MULTIPLE GENERATORS

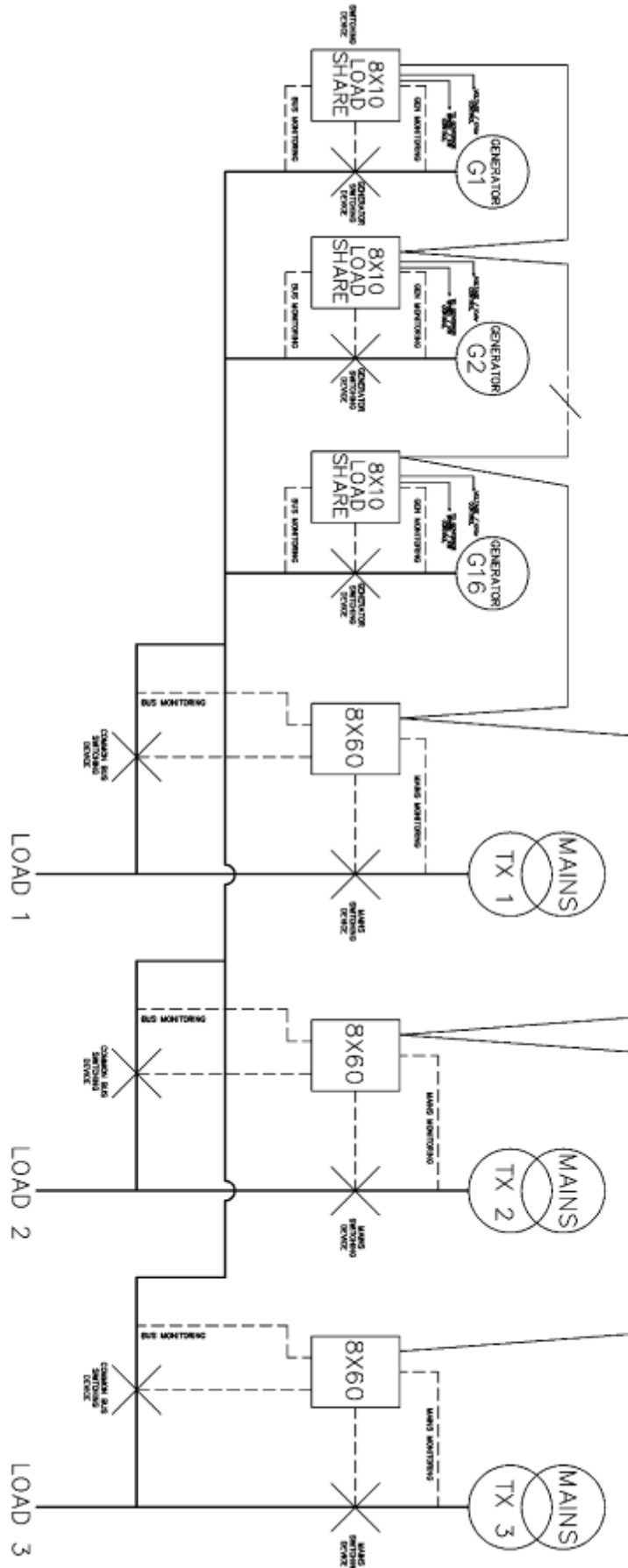

### 4.2.5 DSENET®

DSENet® is the communication port between the host controller (DSE86xx series) and the expansion device as shown below. Further details are contained within the *Specification* section of this document and within the operator manual for the specific expansion module you are connecting to.

**NOTE:** Screened 120Ω impedance cable specified for use with CAN must be used for the DSENet® (RS485) connection.

DSE stock and supply Belden cable 9841 which is a high quality 120Ω impedance cable suitable for DSENet® use (DSE part number 016-030)

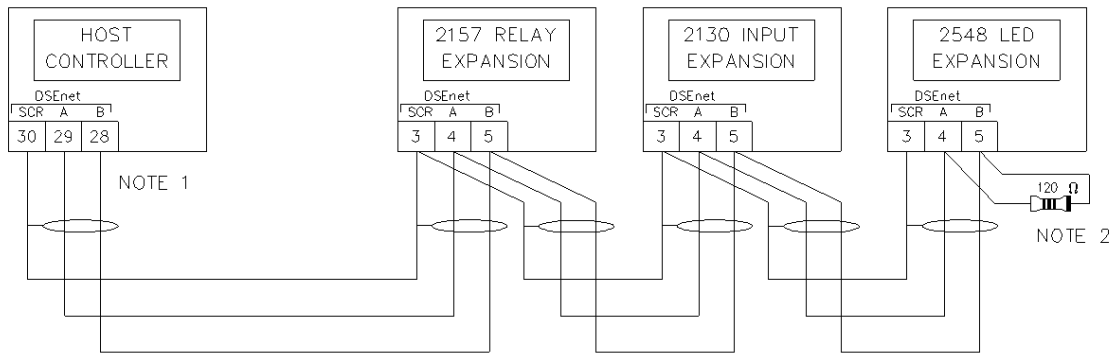

NOTE 1  
AS A TERMINATING RESISTOR IS INTERNALLY FITTED TO THE HOST CONTROLLER, THE HOST CONTROLLER MUST BE THE FIRST UNIT ON THE DSEnet

NOTE 2  
A 120 OHM TERMINATION RESISTOR MUST BE FITTED TO THE LAST UNIT ON THE DSEnet

## **4.2.6 EARTH SYSTEMS**

### **4.2.6.1 NEGATIVE EARTH**

The typical wiring diagrams located within this document show connections for a negative earth system (the battery negative connects to Earth)

### **4.2.6.2 POSITIVE EARTH**

When using a DSE module with a Positive Earth System (the battery positive connects to Earth), the following points must be followed:

- Follow the typical wiring diagram as normal for all sections EXCEPT the earth points
- All points shown as Earth on the typical wiring diagram should connect to BATTERY NEGATIVE (not earth).

### **4.2.6.3 FLOATING EARTH**

Where neither the battery positive nor battery negative terminals are connected to earth, the following points must to be followed

- Follow the typical wiring diagram as normal for all sections EXCEPT the earth points
- All points shown as Earth on the typical wiring diagram should connect to BATTERY NEGATIVE (not earth).

### 4.3 TYPICAL ARRANGEMENT OF DSENET®

Twenty (20) devices can be connected to the DSENet®, made up of the following devices :

Device	Max number supported
DSE2130 Input Expansion	4
DSE2131 Input Expansion	4
DSE2133 Input Expansion	4
DSE2152 Output Expansion	4
DSE2157 Output Expansion	10
DSE2548 LED Expansion	10

**NOTE : DSE8600 series does not support the 2510/2520 display modules.**

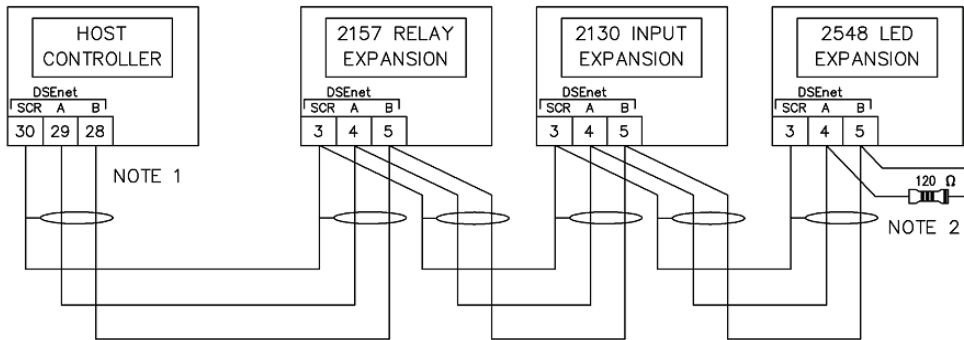

NOTE 1  
 AS A TERMINATING RESISTOR IS INTERNALLY FITTED TO THE HOST CONTROLLER, THE HOST CONTROLLER MUST BE THE FIRST UNIT ON THE DSEnet

NOTE 2  
 A 120 OHM TERMINATION RESISTOR MUST BE FITTED TO THE LAST UNIT ON THE DSEnet

## 5 DESCRIPTION OF CONTROLS

The following section details the function and meaning of the various controls on the module.

### 5.1 DSE8660 AMF CONTROL MODULE

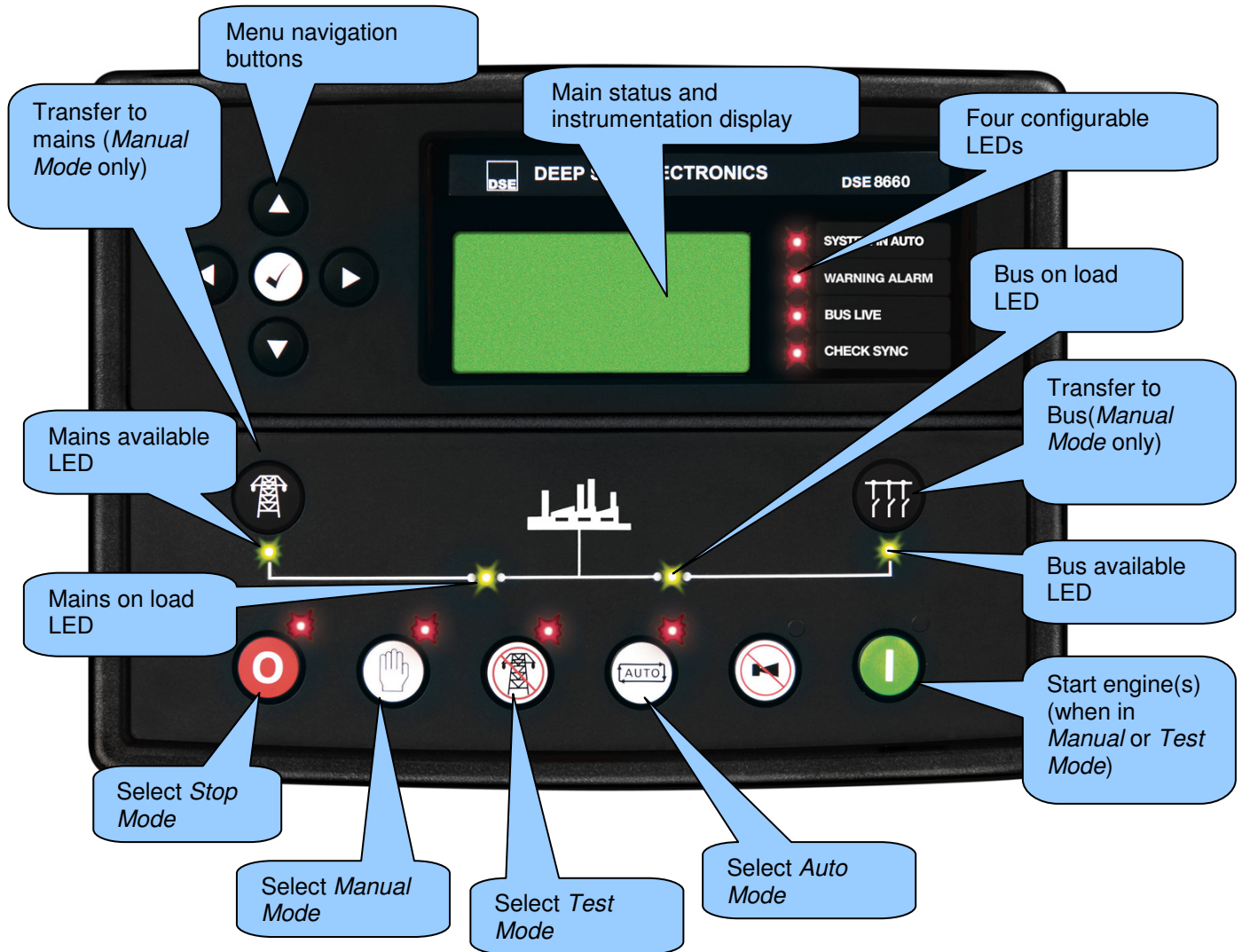

Description of Controls

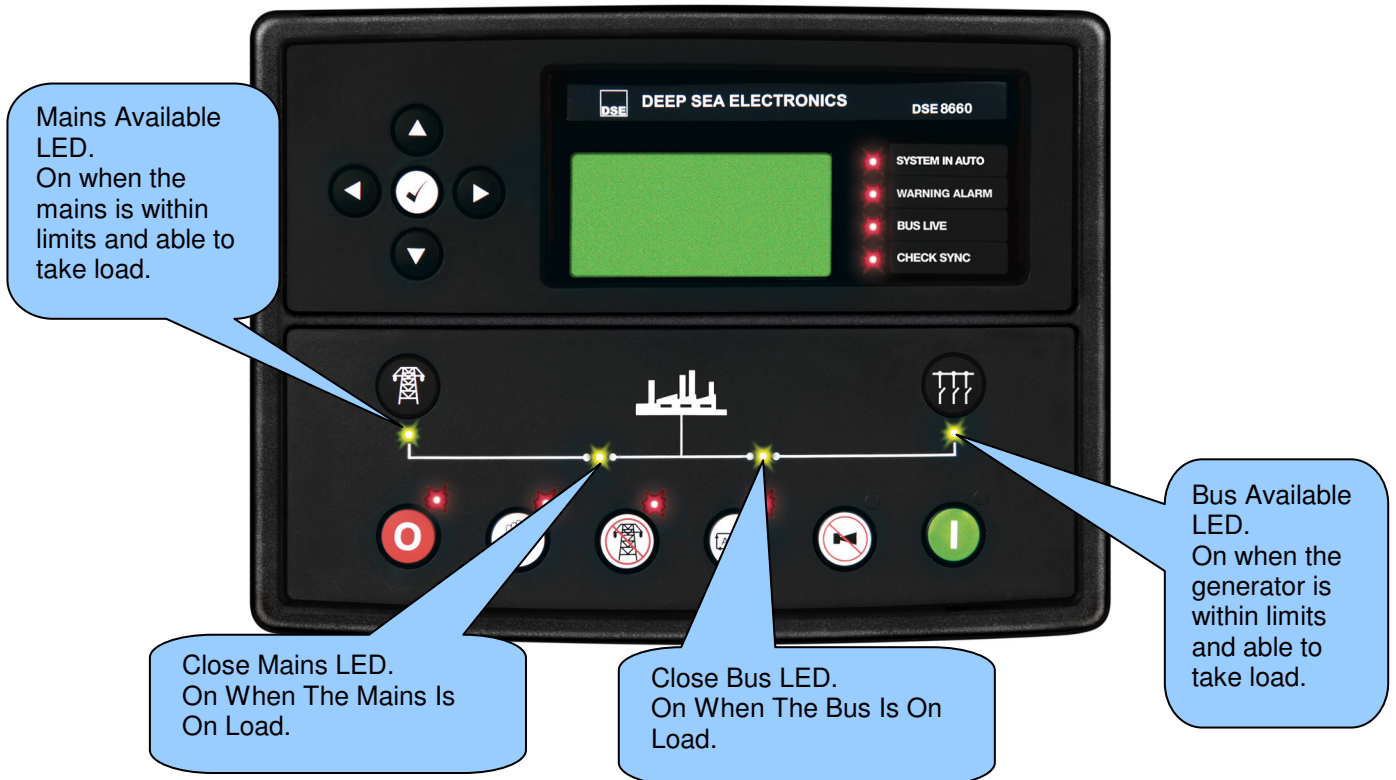

## 5.2 QUICKSTART GUIDE

This section provides a quick start guide to the module's operation.

### 5.2.1 STARTING THE ENGINE(S)



**NOTE:** For further details, see the section entitled 'OPERATION' elsewhere in this manual.

## 5.2.2 STOPPING THE ENGINE(S)



**NOTE:** For further details, see the section entitled 'OPERATION' elsewhere in this manual.



### 5.3 VIEWING THE INSTRUMENT PAGES

It is possible to scroll to display the different pages of information by repeatedly operating the next / previous page

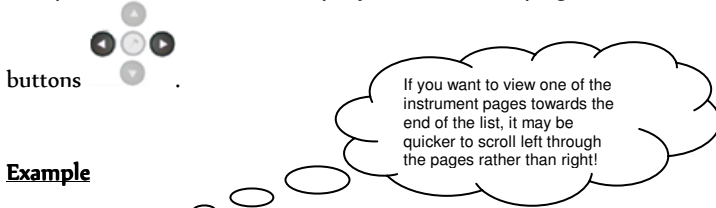

**Example**

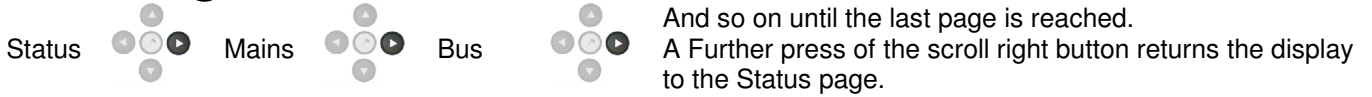

The complete order and contents of each information page are given in the following sections

Once selected the page will remain on the LCD display until the user selects a different page, or after an extended period of inactivity (*LCD Page Timer*), the module will revert to the status display.

If no buttons are pressed upon entering an instrumentation page, the instruments are displayed automatically subject to the setting of the *LCD Scroll Timer*.

The *LCD Page* and *LCD Scroll* timers are configurable using the DSE Configuration Suite Software or by using the Front Panel Editor.

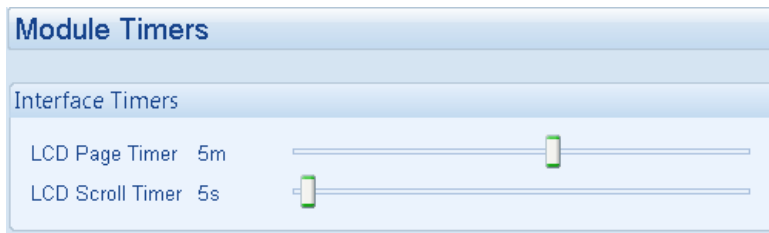

The screenshot shows the factory settings for the timers, taken from the DSE Configuration Suite Software.

Alternatively, to scroll manually through all instruments on the currently selected page, press the scroll buttons. The 'autoscroll' is disabled.

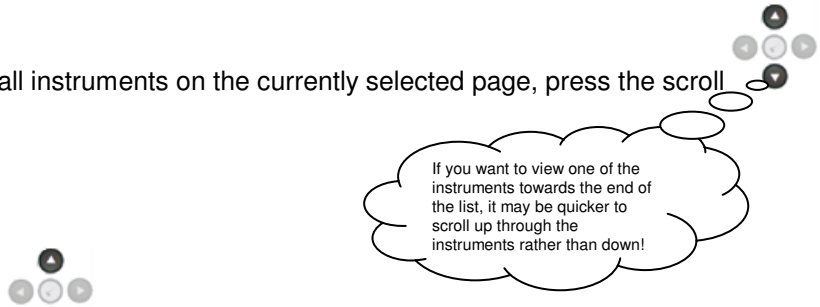

To re-enable 'autoscroll' press the scroll buttons to scroll to the 'title' of the instrumentation page (i.e. Engine). A short time later (the duration of the *LCD Scroll Timer*), the instrumentation display will begin to autoscroll.

When scrolling manually, the display will automatically return to the Status page if no buttons are pressed for the duration of the configurable *LCD Page Timer*.

If an alarm becomes active while viewing the status page, the display shows the Alarms page to draw the operator's attention to the alarm condition.

### 5.3.1 STATUS

This is the 'home' page, the page that is displayed when no other page has been selected, and the page that is automatically displayed after a period of inactivity (*LCD Page Timer*) of the module control buttons.

This page is configurable using the DSE Configuration Suite Software.

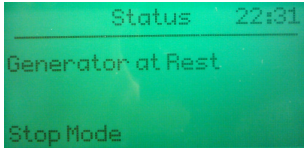

Factory setting of Status screen showing engine stopped...



...and engine running

The contents of this display may vary depending upon configuration by the generator manufacturer / supplier.

The display above was achieved with the factory settings, shown below in the DSE Configuration suite software:

**Configurable Status Screens**

Home Page  
Home Page Mode

Displayed Pages

Page 1	Summary screen	Page 6	Not Used
Page 2	Not Used	Page 7	Not Used
Page 3	Not Used	Page 8	Not Used
Page 4	Not Used	Page 9	Not Used
Page 5	Not Used	Page 10	Not Used

Callout 1: 'Stop Mode' etc is displayed on the Home Page

Callout 2: With a summary of the instrumentation shown when the engine is running.

Callout 3: Other pages can be configured to be shown, automatically scrolling when the set is running.

**NOTE:-** The following sections detail instrumentation pages, accessible using the scroll left and right buttons, regardless of what pages are configured to be displayed on the 'status' screen.

### **5.3.2 MAINS**

Mains Volts (L1-N, L2-N, L3-N)  
Mains Volts (L1-L2, L2-L3, L3-L1)  
Mains Hz  
Mains Amps  
Mains kW  
Mains kVA  
Mains pf  
Mains kVAr  
Mains kWh, kVAh, kVArh  
Mains configuration type  
Synchroscope  
Battery Voltage

### **5.3.3 BUS**

Bus volts (L1-N, L2-N, L3-N)  
Bus volts (L1-L2, L2-L3, L3-L1)  
Bus Hz  
Bus kW  
Bus kVAr  
Bus commissioning screens

### 5.3.4 SERIAL PORT

This section is included to give information about the currently selected serial port and external modem (if connected).

The items displayed on this page will change depending upon configuration of the module. You are referred to your system supplier for further details.

**NOTE:** Factory Default settings are for the RS232 port to be enabled (no modem connected), operating at 19200 baud, modbus slave address 10.

#### **Example 1 – Module connected to a RS232 telephone modem.**

When the DSE86xx series module is power up, it will send 'initialisation strings' to the connected modem. It is important therefore that the modem is already powered, or is powered up at the same time as the DSE86xx series module. At regular intervals after power up, the modem is reset, and reinitialised, to ensure the modem does not 'hang up'.

If the DSE86xx series module does not correctly communicate with the modem, "Modem initialising" will appear on the Serial Port instrument screen as shown overleaf.

If the module is set for "incoming calls" or for "incoming and outgoing calls", then if the modem is dialled, it will answer after two rings (using the factory setting 'initialisation strings'. Once the call is established, all data is passed from the dialling PC and the DSE86xx series module.

If the module is set for "outgoing calls" or for "incoming and outgoing calls", then the module will dial out whenever an alarm is generated. Note that not all alarms will generate a dial out; this is dependant upon module configuration of the event log. Any item configured to appear in the event log will cause a dial out.

Serial Port	
Baud	9600
SlaveID	10
Modem	

Press down  to view the modem status....

Indicates that a modem is configured. Shows 'RS232' if no modem is configured or 'RS485' if the RS485 port is selected.

**Example 1 continued – Modem diagnostics**

**NOTE:-** Modem diagnostic screens are available on 73xx module versions 5 and above only. The modem screens appear only when the module has been configured for use with a modem.



Modem diagnostic screens are included; press  when viewing the *Serial Port* instrument to cycle the available screens. If you are experiencing modem communication problems, this information will aid troubleshooting.

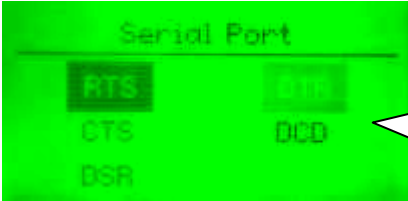

Shows the state of the modem communication lines. These can help diagnose connection problems.

Example:

**RTS** A dark background shows the line is active.

**RTS** a grey background shows that the line is toggling high and low.

**RTS** No background indicates that the line is inactive

Line	Description	
RTS	Request To Send	Flow control
CTS	Clear To Send	Flow control
DSR	Data Set Ready	Ready to communicate
DTR	Data Terminal Ready	Ready to communicate
DCD	Data Carrier Detect	Modem is connected

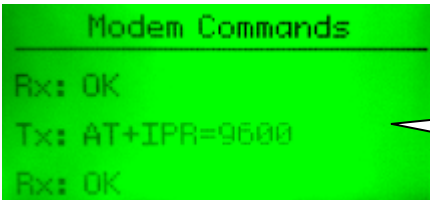

Shows the last command sent to the modem and the result of the command.

Modem Setup Sequence

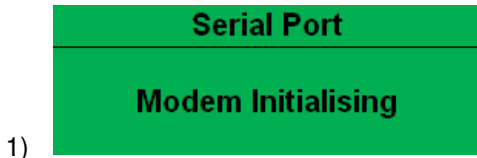

If the Modem and DSE8600 series communicate successfully:

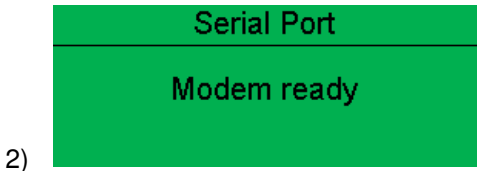

In case of communication failure between the modem and DSE8600 series module, the modem is automatically reset and initialisation is attempted once more:

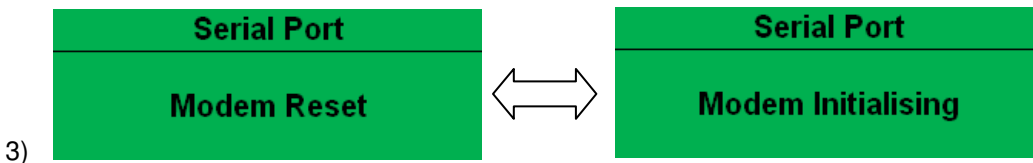

In the case of a module that is unable to communicate with the modem, the display will continuously cycle between 'Modem Reset' and 'Modem Initialising' as the module resets the modem and attempts to communicate with it again, this will continue until correct communication is established with the modem. In this instance, you should check connections and verify the modem operation.

Example 2 – Module connected to a modem.

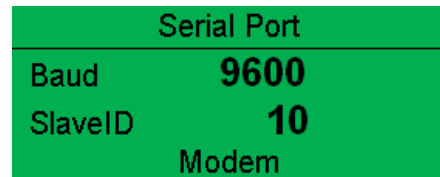

Example 3 – Modem status of a GSM modem

Currently connected GSM operator and signal strength.

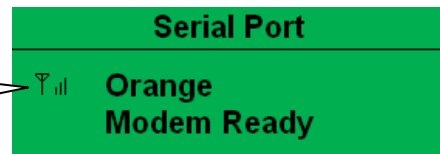

Many GSM modems are fitted with a status LED to show operator cell status and ringing indicator. These can be a useful troubleshooting tool.

In the case of GSM connection problems, try calling the DATA number of the SIMCARD with an ordinary telephone. There should be two rings, followed by the modem answering the call and then 'squealing'. If this does not happen, you should check all modem connections and double check with the SIM provider that it is a DATA SIM and can operate as a data modem. DATA is NOT the same as FAX or GPRS and is often called Circuit Switched Data (CSD) by the SIM provider.

**NOTE:** In the case of GSM modems, it is important that a DATA ENABLED SIM is used. This is often a different number than the 'voice number' and is often called Circuit Switched Data (CSD) by the SIM provider.

If the GSM modem is not purchased from DSE, ensure that it has been correctly set to operate at 9600 baud. You may need to install a terminal program on your PC and consult your modem supplier to do this. GSM modems purchased from DSE are already configured to work with the DSE86xx series module.

**Example 4 - Module RS485 port configured for connection to a modbus master.**

Serial Port	
Baud	19200
SlaveID	1
RS485	

DSE86xx series modules operate as a modbus RTU slave device. In a modbus system, there can be only one Master, typically a PLC, HMI system or PC SCADA system.

This master requests for information from the modbus slave (DSE86xx series module) and may (in control systems) also send request to change operating modes etc. Unless the Master makes a request, the slave is 'quiet' on the data link.

The factory settings are for the module to communicate at 19200 baud, modbus slave address 10.

To use the RS485 port, ensure that 'port usage' is correctly set using the DSE Configuration Suite Software.

Required settings are shown below.

The screenshot shows the 'Serial Port Configuration' window with the following settings: Slave ID is 10, Baud Rate is 19200, and Port Usage is RS485. Below this is the 'Connection Settings' window, which shows the Master inactivity timeout set to 5s.

'Master inactivity timeout' should be set to at least twice the value of the system scan time. For example if a modbus master PLC requests data from the DSE86xx modbus slave once per second, the timeout should be set to at least 2 seconds.

The DSE Modbus Gencomm document containing register mappings inside the DSE module is available upon request from [support@deepseapl.com](mailto:support@deepseapl.com). Email your request along with the serial number of your DSE module to ensure the correct information is sent to you.

**Typical requests (using Pseudo code)**

BatteryVoltage=ReadRegister(10,0405,1) : reads register (hex) 0405 as a single register (battery volts) from slave address 10.

WriteRegister(10,1008,2,35701, 65535-35701): Puts the module into AUTO mode by writing to (hex) register 1008, the values 35701 (auto mode) and register 1009 the value 65535-35701 (the bitwise opposite of auto mode)

Warning=(ReadRegister(10,0306,1) >> 11) & 1 : reads (hex) 0306 and looks at bit 12 (Warning alarm present)

ElectricalTrip=(ReadRegister(10,0306,1) >> 10) & 1 : reads (hex) 0306 and looks at bit 11 (Electrical Trip alarm present)

ControlMode=ReadRegister(10,0304,2); reads (hex) register 0304 (control mode).

### 5.3.5 ABOUT

Contains important information about the module and the firmware versions. This information may be asked for when contacting DSE Technical Support Department for advice.

- Module Type (i.e. 8610, 8660)
- Application Version – The version of the module’s main firmware file – Updatable using the Firmware Update Wizard in the DSE Configuration Suite Software.
- USB ID – unique identifier for PC USB connection
- Analogue Measurements software version
- Firmware Update Boot loader software version

#### 5.3.5.1 ETHERNET PAGES

- Update Network settings using DSE Configuration Suite Software+ 1 Power cycle off/on before the editor pages are updated..

Network  
IP address  
192.xxx.xx.xx  
DHCP Disabled

Network  
Subnet mask  
255.255.255.0

Network  
Gateway address  
192.xxx.xx.xxx

Network  
DNS address  
192.xxx.xx.xx

Network  
MAC address  
E8.A4.C1.0.A.C2

Unique setting for each module

DHCP  
HOST  
DOMAIN  
Vendor

MODBUS over IP  
TCP Port 502  
Pref IP 0.0.0.0

Pages available in the “ABOUT” screen to confirm Network settings.



### 5.3.5.2 DATA LOGGING PAGES

The DSE data logging pages show information depending on the configuration in the module.

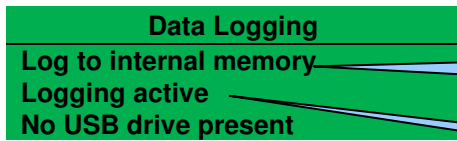

Location of stored data.  
Internal module memory or external  
USB memory.

If data logging is active or inactive

Inserting a USB drive to the host USB will display the following change to the page.

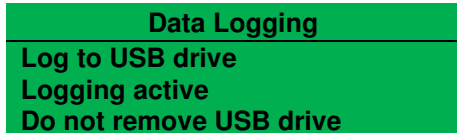

**NOTE:- Removal of the USB drive should only be carried out using the following method.**

Press and hold the  tick button until "Ok to remove USB drive" is displayed.

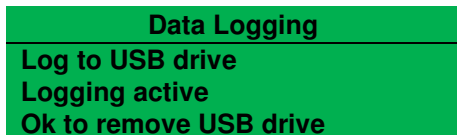

It is now safe to remove the USB drive.  
This ensures the logging data file will save to memory complete and will not become corrupt.

Press down  to view the next page.

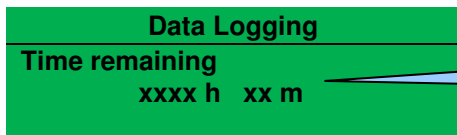

Remaining time available for logging  
information.  
xxxx hours xx minutes

Press down  to view the next page.

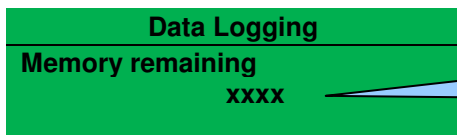

Memory space remaining, this depends  
what size memory drive is fitted (Max  
16Gb) or allocated internal (2Mb)  
memory left available.

## 5.4 VIEWING THE EVENT LOG

The DSE8600 series modules maintain a log of past alarms and/or selected status changes. The log size has been increased in the module over past module updates and is always subject to change. At the time of writing, the 86xx series log is capable of storing the last 250 log entries.

Under default factory settings, the event log only includes shutdown and electrical trip alarms logged (The event log does not contain Warning alarms), however this is configurable by the system designer using the DSE Configuration Suite software.

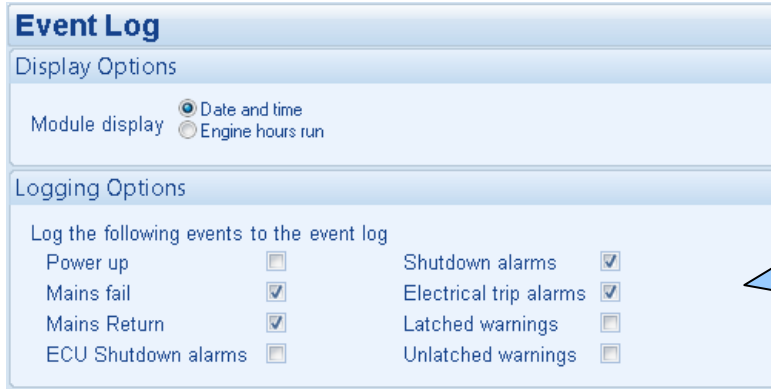

Example showing the possible configuration of the DSE8600 series event log (DSE Configuration Suite Software)  
This also shows the factory settings of the module (Only shutdown alarms and the mains status are logged).

Once the log is full, any subsequent shutdown alarms will overwrite the oldest entry in the log. Hence, the log will always contain the most recent shutdown alarms. The module logs the alarm, along with the date and time of the event. If the module is configured and connected to send SMS text, a text of the event is sent also.



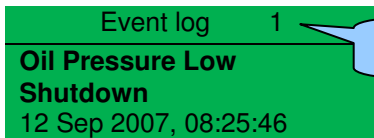

To view the event log, repeatedly press the next page button until the LCD screen displays the Event log :



This is event 1.

Press down  to view the next most recent shutdown alarm:

Continuing to press down  cycles through the past alarms after which the display shows the most recent alarm and the cycle begins again.

To exit the event log and return to viewing the instruments, press the next page  button to select the next instrumentation page.







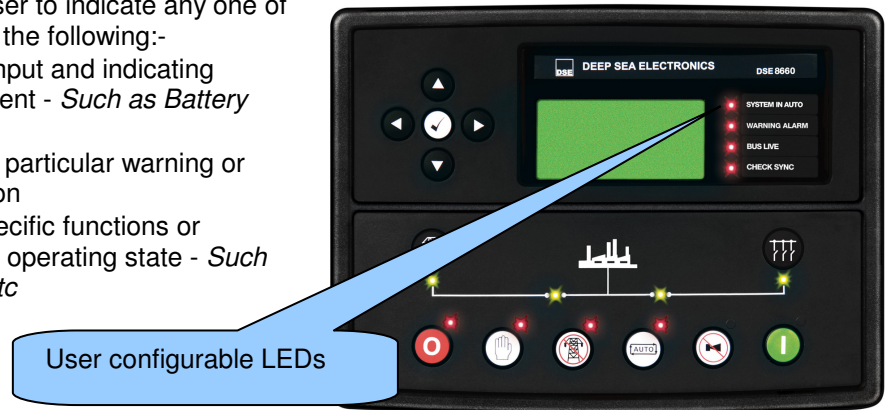



## 5.5 USER CONFIGURABLE INDICATORS



These LEDs can be configured by the user to indicate any one of **100+ different functions** based around the following:-

- **Indications** - Monitoring of a digital input and indicating associated functioning user's equipment - *Such as Battery Charger On or Louver's Open, etc.*
- **WARNINGS** - Specific indication of a particular warning or condition, backed up by LCD indication
- **Status Indications** - Indication of specific functions or sequences derived from the modules operating state - *Such as, Panel Locked, Mains Available, etc*



## 5.6 CONTROLS

<p><b>Stop / Reset</b>                  This button places the module into its <b>Stop/Reset</b> mode. This will clear any alarm conditions for which the triggering criteria have been removed. If the engine(s) is(are) running and the module is in Stop mode, the module will automatically instruct the changeover device to unload the generator bus (<b>'Close Bus becomes inactive (if used)'</b>). The start request is taken away. Should a <b>remote start signal</b> be present while operating in this mode, a remote start will <u>not</u> occur.</p>	
<p><b>Manual</b>                  This mode allows manual control of the functions. Once in <b>Manual mode</b> the module will respond to the start  button, sending a start request to the engine(s) over the MSC link. If the engine is running off-load in the <b>Manual mode</b> and a <b>remote start signal</b> becomes present, the module will automatically instruct the changeover device to place the generator bus on load (<b>'Close Bus becomes active (if used)'</b>). Upon removal of the <b>remote start signal</b>, the generator bus remains on load until either selection of the <b>'STOP/RESET'</b> or <b>'AUTO'</b> modes.  <i>For further details, please see the more detailed description of 'Manual operation' elsewhere in this manual.</i></p>	
<p><b>Auto</b>                  This button places the module into its <b>'Automatic'</b> mode. This mode allows the module to control the function of the system automatically. The module will monitor the <i>remote start</i> input and mains supply status and once a start request is made, the set(s) will be automatically started and placed on load. Upon removal of the starting signal, the module will automatically transfer the load from the generator bus and shut the set(s) down observing the <i>stop delay</i> timer and <i>cooling</i> timer as necessary. The module will then await the next start event. <i>For further details, please see the more detailed description of 'Auto operation' elsewhere in this manual.</i></p>	
<p><b>Test</b>                  This button places the module into its <b>'Test'</b> mode. This allows an on load test of the generator(s).                  Once in <b>Test mode</b> the module will respond to the start  button, sending a start request to the engine(s) over the MSC link, and run on load, in parallel with the mains supply.  <i>For further details, please see the more detailed description of 'Test operation' elsewhere in this manual.</i></p>	
<p><b>Start</b>                  This button is only active in TEST  or MANUAL  mode.                  Pressing this button in manual or test mode will request the engines to start and run off load (manual) or on load (test).</p>	
<p><b>Mute / Lamp Test</b>                  This button silences the audible alarm if it is sounding and illuminates all of the LEDs as a lamp test feature.</p>	

<p><b>CLOSE MAINS</b>                  This push button is used to control the closure of the mains load switching device and has two modes of operation :</p> <ol style="list-style-type: none"> <li>1. Synchronising is NOT enabled. Pressing this button when the mains is available off load and in MANUAL mode, the bus load switch is opened and the mains load switch is closed. Further presses of this button will have no effect.</li> <li>2. Synchronising is enabled. Pressing this button when the mains is available and in MANUAL mode, the 8660 controller, will volts match and synchronise with the Bus. The mains load switch is then closed in parallel with the Bus.</li> </ol>	
<p><b>▲ NOTE: This button is only active in MANUAL mode.</b></p>	
<p><b>▲ NOTE: If the bus is live when the manual button is pressed, synchronising will take place before the load switch is closed.</b></p>	
<p><b>CLOSE BUS</b>                  This push button is used to control the closure of the bus load switching device and has two modes of operation :</p> <ol style="list-style-type: none"> <li>3. Synchronising is NOT enabled. Pressing this button when the bus is off load and in MANUAL mode, the mains load switch is opened and the bus load switch is closed. Further presses of this button will have no effect.</li> <li>4. Synchronising is enabled. Pressing this button when the bus is live and in MANUAL mode, the 8660 controller, will volts match and synchronise with the Mains. The bus load switch is then closed in parallel with the mains.</li> </ol>	
<p><b>▲ NOTE: This button is only active in MANUAL mode.</b></p>	
<p><b>▲ NOTE: If the bus is live when the manual button is pressed, synchronising will take place before the load switch is closed.</b></p>	
<p><b>Menu navigation</b>                   Used for navigating the instrumentation, event log and configuration screens.                  For further details, please see the more detailed description of these items elsewhere in this manual.</p>	

## 6 OPERATION

The following description details the sequences followed by a module containing the standard '*factory configuration*'.

Remember that if you have purchased a completed generator set or control panel from your supplier, the module's configuration will probably have been changed by them to suit their particular requirements.

Always refer to your configuration source for the exact sequences and timers observed by any particular module in the field.

### 6.1 ALTERNATIVE CONFIGURATIONS

Depending upon the configuration of your system by the generator supplier, the system may have selectable configurations (for example to select between 50Hz and 60Hz running). If this has been enabled your generator supplier will advise how this selection can be made (usually by externally operated selector switch or by selecting the required configuration file in the DSE8600 series front panel configuration editor).

## 6.2 STOP MODE

STOP mode is activated by pressing the  button.

In STOP mode, the module will remove the generator bus from load (if necessary) before remove the start request from the engines.

Any latched alarms (electrical trip) that have been cleared are reset when STOP mode is entered.

The engine will not be started by the DSE8660 when in STOP mode. If remote start signals are given or the mains supply fails, the start request is not sent to the engines until AUTO mode is entered.

If *Immediate mains dropout* is enabled, the mains load switch is opened and closed as appropriate, when the mains fails or becomes available to take load.

## 6.3 AUTOMATIC MODE

 **NOTE: If a digital input configured to *panel lock* is active, changing module modes will not be possible. Viewing the instruments and event logs is NOT affected by panel lock.**

Activate auto mode by pressing the  pushbutton. An LED indicator beside the button confirms this action.

Auto mode will allow the generator to operate fully automatically, starting and stopping as required with no user intervention.

### 6.3.1 WAITING IN AUTO MODE

If a starting request is made, the starting sequence will begin. Starting requests can be from the following sources:

- Mains supply out of limits
- High mains load (when the DSE8660 is configured for an automatic peak lopping system)
- Activation of an auxiliary input that has been configured to *remote start on load*, *remote start in island mode* or *remote start off load*.
- Activation of an auxiliary input that has been configured to *Aux Mains Failure*.
- Activation of the inbuilt exercise scheduler.
- Instruction from external remote telemetry devices using the RS232 or RS485 interface.

### 6.3.2 STARTING SEQUENCE

To allow for 'false' start requests such as mains brownouts, the *start delay* timer begins. There are individual start delay timers for each of the different start request types.

Should all start requests be removed during the *start delay* timer, the unit will return to a stand-by state.

If a start request is still present at the end of the *start delay* timer, the starting request is sent to the engine(s) over the MSC data link.

### 6.3.3 ENGINE RUNNING

Once the generator bus becomes available, the load is transferred. If required, the generator bus is first synchronised with the mains supply. This operation is automatic, using the MSC data link. Load ramping takes place when appropriate, the DSE8660 controls the generator(s) bus to provide the configured power to the load and/or mains supply.

#### 6.3.3.1 BUS MODE

In this mode, the generator(s) are used to provide a **fixed** amount of active power (kW), this is configured into the *Load parallel power* parameter.

How much reactive power is provided depends upon the kVAr/pf selection:

⊙ KVAr – The generator(s) will provide the number of KVAr configured into the *Load Parallel VAr* parameter. The power factor is variable in order to achieve this.

⊙ Pf – The generator(s) will product power at the power factor configured into the *Load power factor* parameter. The kVAr is variable in order to achieve this.

#### 6.3.3.2 MAINS MODE

In this mode, the generator(s) are used to provide a **variable** amount of active power (kW), to maintain the mains import/export levels at the configured values. This is configured into the *Load parallel power* parameter.

How much reactive power is taken from or exported to the mains depends upon the kVAr/pf selection:

⊙ KVAr – The generator(s) will be used to provide enough kVAr to keep the mains import/export VAr at the level configured into the *Load Parallel VAr* parameter. The mains power factor is variable in order to achieve this.

⊙ Pf – The generator(s) will be used to provide enough kVAr to keep the mains import/export at the power factor configured into the *Load power factor* parameter. The mains kVAr is variable in order to achieve this.

As the load increases and decreases, sets may automatically start and stop, depending upon their configuration. If all start requests are removed, the *stopping sequence* will begin.

### 6.3.4 STOPPING SEQUENCE

The *return delay* timer operates to ensure that the starting request has been permanently removed and is not just a short-term removal.

If there are no starting requests at the end of the *return delay* timer, the load is transferred back from the generator bus to the mains supply and the start request is removed from the engine(s).



## 6.4 MANUAL MODE

**NOTE:** If a digital input configured to *panel lock* is active, changing module modes will not be possible. Viewing the instruments and event logs is NOT affected by panel lock.

Activate Manual mode by pressing the  pushbutton. An LED indicator beside the button confirms this action.

Manual mode allows the operator to start and stop the set(s) manually, and if required change the state of the load switching devices.

### 6.4.1 WAITING IN MANUAL MODE

When in manual mode, the set(s) will not start automatically.

To begin the starting sequence, press the  button.



### 6.4.2 ENGINE RUNNING

In manual mode, the load is not transferred to the generator bus unless a 'loading request' is made. A loading request can come from a number of sources.

- Pressing the *transfer to bus*  button
- Mains supply out of limits.
- Activation of an auxiliary input that has been configured to *remote start on load, remote start in island mode or remote start off load*.
- Activation of an auxiliary input that has been configured to *Aux Mains Failure*.
- Activation of the inbuilt exercise scheduler if configured for 'on load' runs.



Parallel operation is governed by configuration. See the previous section *Auto Mode: Engine Running* for further details.

Once bus and mains are in parallel, you can either

- Press the *transfer to bus*  button. The load is ramped to the bus, the mains breaker is opened.
- Press the *transfer to mains*  button. The load is transferred to the mains. The generator bus breaker is opened.
- Press the *auto mode*  button to return to automatic mode.

### 6.4.3 STOPPING SEQUENCE

In manual mode, the set will continue to run until either:

- The *stop button*  is pressed – The set are requested to stop
- The *auto button*  is pressed. The set will observe all auto mode start requests and stopping timers before beginning the *Auto mode stopping sequence*.

## 6.5 TEST MODE

**NOTE:** If a digital input configured to *panel lock* is active, changing module modes will not be possible. Viewing the instruments and event logs is NOT affected by panel lock.

Activate test mode by pressing the  pushbutton. An LED indicator beside the button confirms this action.

Test mode will start the set(s) and parallel the mains to the generator bus to provide a **Test on load** function. Depending upon configuration this can be continuous parallel or island mode operation.

### 6.5.1 WAITING IN TEST MODE



When in test mode, the set will not start automatically.

To begin the starting sequence, press the  button.

### 6.5.2 ENGINE RUNNING

Parallel operation is governed by configuration. See the previous section entitled *Auto Mode: Engine Running* for further details.

In test mode, the set will continue to run *on load* until either:

- The *stop button*  is pressed – The generator bus breaker is opened and the set(s) are called to stop.
- The *auto button*  is pressed. The set(s) will observe all auto mode start requests and stopping timers before beginning the *Auto mode stopping sequence*.

## 6.6 MULTIPLE MAINS OPERATION

In a multiple mains system, the generator sets are controlled by more than one 8660 mains controller and used to provide power to multiple loads.

Should one or more of the mains supplies fail, the generators (controlled by DSE 8610 modules) are started and supply power to the load. If more than one mains supply has failed, the loads are transferred to the generators one by one.

The 8610 controllers share power equally on a percentage basis with the other generators in the system.

- If one mains supply returns, the 8660 connected to that mains supply will synchronise the generators with the mains and affect a no-break changeover. The generators continue to supply power to the remaining loads.
- If more than one mains supply returns at the same time, then the 8660 with the highest priority will take control of the generators and affect a no-break changeover back to the mains supply. The remaining 8660s will operate in priority order providing no-break returns back to their respective mains supplies.

If the generators are 'peak-opping' with one mains supply, and another mains supply fails, dependent upon module configuration, the generators will either:

- Continue to peak-lop as before. The load with the mains supply that has failed will remain without power.
- Cease peak-opping and backup the failed mains supply.

**NOTE:** At no time are the generators paralleled with more than one mains supply at a time. Paralleling with mains supplies is always taken in turn.

### 6.6.1 8660 PRIORITY

Where more than one 8660 controller is present, they must determine which one is to take control over the generators. The following table shows how this priority decision is made.

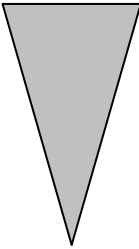
Priority	Condition
	Auto mode, mains failed, bus not on load
	Auto mode, mains has returned
	Auto mode, mains failed, bus on load
	Auto mode, mains available, requesting control over generators
	Test on load mode
	Manual mode, sets running or about to run (start button has been pressed)
	Auto mode, mains available
	Manual mode, sets not running (waiting for start button to be pressed)
	Stop mode

Where two or more 8660 controllers have the same conditions in the table above, the 'Set Priority' configuration setting comes into effect. If two or more 8660 controllers have the same priority number, an electrical trip alarm is generated - Priority Selection Error - and the priority numbers must be changed before the system will operate.

**NOTE:** If a 8660 requests to control the generators (either automatically or manually) it will not be allowed to do so until higher priority 8660 controllers have relinquished control over them.

For typical one line diagram of a multi-mains system, see the section entitled "Typical system schematics" elsewhere in this manual.

## **6.6.2 8660 LOAD CT**

The 8660 controller incorporates an optional (but recommended) extra CT measuring the size of the load. Used in conjunction with the CTs measuring the amount of load on the mains supply, this CT allows the 8660 to determine what portion of the load is being supplied by the generators.

This allows the 8660 to remove the sets from this load when there is little or no current passing through the bus breaker. For example: When the generators are ramping off load.

## 7 PROTECTIONS

When an alarm is present, the Audible Alarm will sound and the Common alarm LED if configured will illuminate.

The audible alarm can be silenced by pressing the *Mute button* 

The LCD display will jump from the 'Information page' to display the Alarm Page

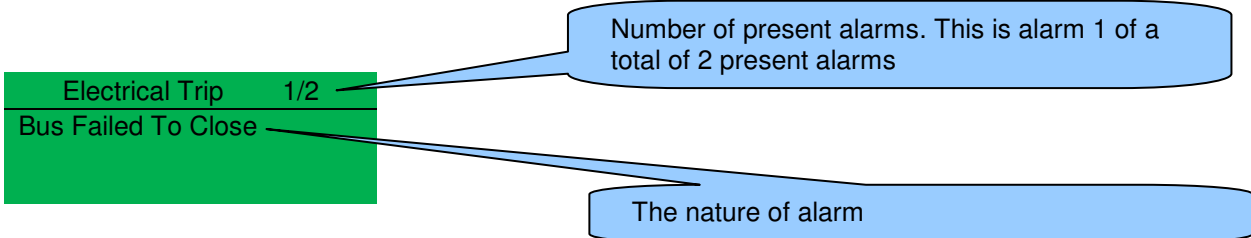

The LCD will display multiple alarms. These will automatically scroll in the order that they occurred.

### 7.1 INDICATIONS

Indications are non-critical and often status conditions. They do not appear on the LCD of the module as a text message. However, an output or LED indicator can be configured to draw the operator's attention to the event.

#### Example

- Input configured for indication.
- The LCD text will not appear on the module display but can be added in the configuration to remind the system designer what the input is used for.
- As the input is configured to *Indication* there is no alarm generated.
- LED Indicator to make LED1 illuminate when Digital Input A is active.
- The Insert Card Text allows the system designer to print an insert card detailing the LED function.
- Sample showing operation of the LED.

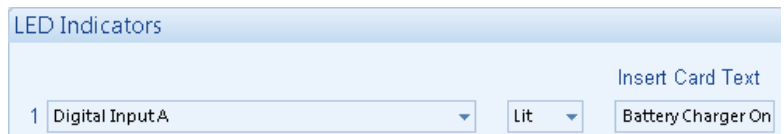
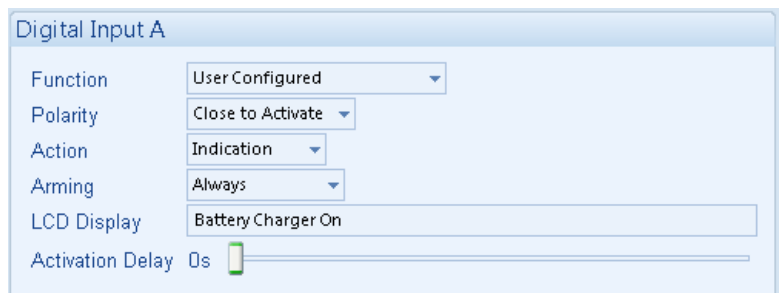

## 7.2 WARNINGS

Warnings are non-critical alarm conditions and do not affect the operation of the generator system, they serve to draw the operators attention to an undesirable condition.

In the event of an alarm the LCD will jump to the alarms page, and scroll through all active warnings and shutdowns.

By default, warning alarms are self-resetting when the fault condition is removed. However enabling 'all warnings are latched' will cause warning alarms to latch until reset manually. This is enabled using the 8600 series configuration suite in conjunction with a compatible PC.

Display	Reason
<b>BATTERY UNDER VOLTAGE</b>	The DC supply has fallen below the low volts setting level for the duration of the low battery volts timer
<b>BATTERY OVER VOLTAGE</b>	The DC supply has risen above the high volts setting level for the duration of the high battery volts timer
<b>AUXILIARY INPUTS</b>	Auxiliary inputs can be user configured and will display the message as written by the user.
<b>kW OVERLOAD</b>	The measured Total kW is above the setting of the kW overload warning alarm

### 7.3 ELECTRICAL TRIPS

Electrical trips are latching and stop the Generator but in a controlled manner. On initiation of the electrical trip condition the module will de-energise the ‘Close Generator’ Output to remove the load from the generator. Once this has occurred the start request is removed. The alarm must be accepted and cleared, and the fault removed to reset the module.

Electrical trips are latching alarms and stop the Generator(s). Remove the fault then press Stop/Reset  to reset the module.



Display	Reason
<b>AUXILIARY INPUTS</b>	If an auxiliary input configured as an electrical trip is active, the appropriate message will be displayed as configured by the user.
<b>KW OVERLOAD</b>	The measured Total kW is above the setting of the kW overload Electrical Trip alarm
<b>MSC OLD UNITS ON BUS</b>	If the module detects a module on the MSC link which is incompatible with the current module, then the MSC Compatibility alarm will be triggered. Check all the modules’ version numbers (under <i>About   Application Number</i> on the modules’ displays), modules pre V3 cannot communicate with modules V4 and onwards. Use the DSE Configuration Suite Software to upgrade the firmware ( <i>Tools   Update Firmware</i> ) of the older modules to V4 and onwards.

### 7.4 ROCOF / VECTOR SHIFT

When configured to run in parallel with the mains (utility) supply, the module monitors for ROCOF / Vector shift trips according to the module’s configuration settings. This is included within the module and will detect failure of the mains supply during parallel operation with the generator.

 **NOTE: This protection operates only when in parallel with the mains supply and is disabled at all other times.**

Should either of these alarms operate, the module will perform a controlled shutdown (electrical trip) of the generator. This operation must be manually reset :

- 1) Press  button. The engine will stop if it is still running and the alarm is cleared.
- 2) Activate digital input configured to “Clear ROCOF/Vector shift” if this has been provided.
- 3) Press  and  button together and hold for 5 seconds. The ROCOF/Vector shift instrument is displayed and all ‘peak hold’ values are reset, clearing the ROCOF/Vector shift alarm.

For details on activating and configuring the ROCOF/Vector shift protection, you are referred to the 8600 configuration software manual.

## 8 SCHEDULER

DSE8600 Series contains an inbuilt exercise run scheduler, capable of automatically starting and stopping the set. Up to 16 scheduled start/stop sequences can be configured to repeat on a 7-day or 28-day cycle. Scheduled runs may be on load or off load depending upon module configuration.

### Example

Screen capture from DSE Configuration Suite Software showing the configuration of the Exercise Scheduler.

In this example the set will start at 09:00 on Monday and run for 5 hours, then start at 13:30 on Tuesday and run for 30 minutes.

The screenshot shows the 'Scheduler' configuration window. At the top, it is titled 'Scheduler' and 'Exercise Scheduler'. Below the title, there are three options: 'Enabled' (checked), 'Scheduled runs are On Load' (unchecked), and 'Schedule Period' (Weekly). The main area contains a table of 16 scheduled runs. Each row has a dropdown menu for the day, a start time, an end time, and a 'Clear' button. The first row is Monday, 09:00 to 05:00. The second row is Tuesday, 13:30 to 00:30. The remaining 14 rows are all Monday, 00:00 to 00:00.

### 8.1.1 STOP MODE

- Scheduled runs will not occur when the module is in STOP/RESET mode.

### 8.1.2 MANUAL MODE

- Scheduled runs will not occur when the module is in MANUAL mode.
- Activation of a Scheduled Run 'On Load' when the module is operating OFF LOAD in Manual mode will have no effect, the set continues to run OFF LOAD

### 8.1.3 AUTO MODE

- Scheduled runs will operate ONLY if the module is in AUTO mode with no Shutdown or Electrical Trip alarm present.
- If the module is in STOP or MANUAL mode when a scheduled run begins, the engine will not be started. However, if the module is moved into AUTO mode during a scheduled run, the engine will be called to start.
- Depending upon configuration by the system designer, an external input can be used to inhibit a scheduled run.
- If the engine is running OFF LOAD in AUTO mode and a scheduled run configured to 'On Load' begins, the set is placed ON LOAD for the duration of the Schedule.



## 9 FRONT PANEL CONFIGURATION

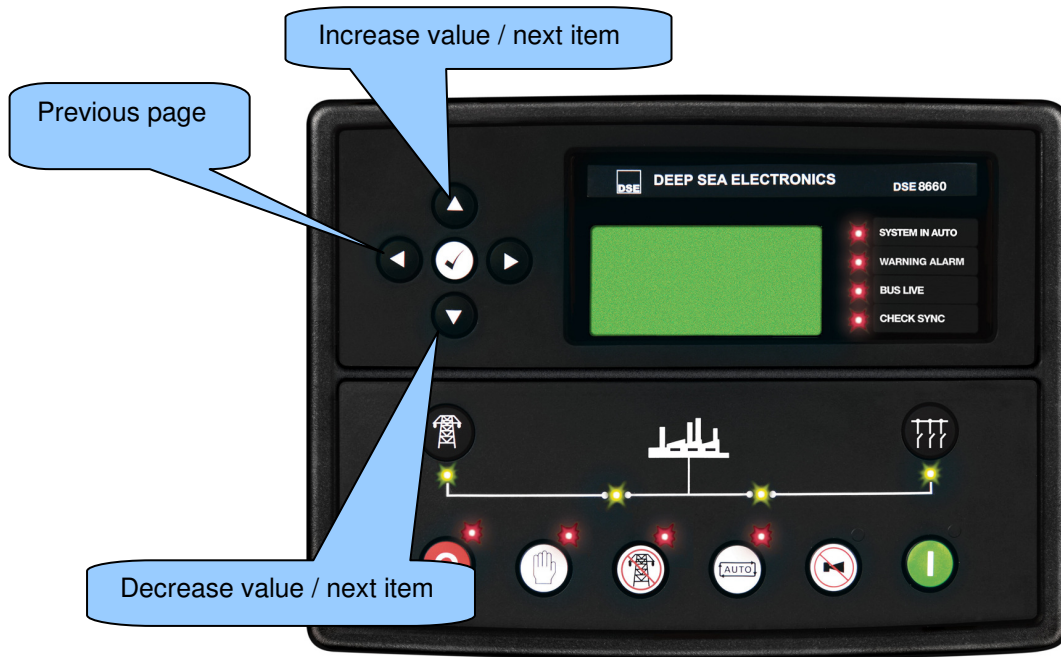

This configuration mode allows the operator limited customising of the way the module operates.

Use the module's navigation buttons to traverse the menu and make value changes to the parameters:



## 9.1 ACCESSING THE MAIN FRONT PANEL CONFIGURATION EDITOR

Ensure the engine is at rest and the module is in STOP mode by pressing the Stop/Reset  button.

Press the Stop/Reset  and Info  buttons simultaneously.  
If a module security PIN has been set, the PIN number request is then shown :

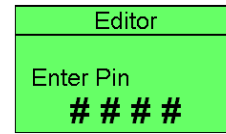

Press , the first '#' changes to '0'. Press  (up or down) to adjust it to the correct value.

Press  (right) when the first digit is correctly entered. The digit you have just entered will now show '#' for security.

Repeat this process for the other digits of the PIN number. You can press  (left) if you need to move back to adjust one of the previous digits.

When  is pressed after editing the final PIN digit, the PIN is checked for validity. If the number is not correct, you must re-enter the PIN.

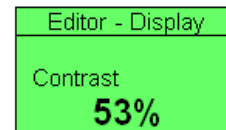

If the PIN has been successfully entered (or the module PIN has not been enabled), the editor is displayed :





**NOTE:** The PIN number is not set by DSE when the module leaves the factory. If the module has a PIN code set, this has been affected by your generator supplier who should be contacted if you require the code. If the code has been 'lost' or 'forgotten', the module must be returned to the DSE factory to have the module's code removed. A charge will be made for this procedure.  
**NB - This procedure cannot be performed away from the DSE factory.**

### 9.1.1 EDITING A PARAMETER

Enter the editor as described above.

Press the  (left) or  (right) buttons to cycle to the section you wish to view/change.

Press the  (up or down) buttons to select the parameter you wish to view/change within the currently selected section.

To edit the parameter, press  to enter edit mode. The parameter begins to flash to indicate that you are editing the value.

Press the  (up or down) buttons to change the parameter to the required value.

Press  to save the value. The parameter ceases flashing to indicate that it has been saved.

To exit the editor at any time, press and hold the  button.



**▲NOTE: The editor automatically exits after 5 minutes of inactivity to ensure security.**

**▲NOTE: The PIN number is automatically reset when the editor is exited (manually or automatically) to ensure security.**

**▲ NOTE: More comprehensive module configuration is possible using the 86xx series PC configuration software. Please contact us for further details.**

### 9.1.2 ADJUSTABLE PARAMETERS

Front Panel Configuration Editor

Section	Parameter as shown on display	Factory Settings
<b>Display</b>	Contrast	53%
	Language	English, others.
	Current Date and Time	hh:mm
<b>Timers</b>	LCD Page Timer	5m
	Scroll Delay	2s
	Battery Under voltage warning Delay	1m
	Battery Over voltage warning Delay	1m
	Start Delay Off Load	5s
	Start Delay On Load	5s
	Start Delay Telemetry	5s
	Start Delay Mains Fail	5s
	Mains Transient Delay	2s
	Return Delay	30s
	Mains Transfer Time	0.7s
<b>Mains</b>	Under voltage Trip	184v
	Over voltage Trip	276v
	Under Frequency Trip	45Hz
	Over Frequency Trip	55Hz
	CT Primary	600A
	CT Secondary	5A
	Mains KW Rating	345kw
	Mains KVar Rating	258kw
<b>Bus</b>	AC System	3 Phase 4 wire
	Start Delay On Load	5s
	Load Ramp Rate	3%/s
	Insufficient Capacity Delay	1s
	Battery Under volts warning	Active
	Battery Under volts warning Delay	1m
	Battery Under volts warning	10V
	Battery Over volts warning	Active
	Battery Over volts warning Delay	1m
	Battery Over volts warning	30V
	Load Level For More Sets	80%
	Load Level For Less Sets	70%
	Load Ramp Rate	3%/s
Enable MSC Compatibility	Inactive	
<b>Schedule</b>	Scheduler	Inactive
	Schedule Loading On Load	Inactive (Only Available when Scheduler Is Active)
	Schedule Period	weekly (Only Available when Scheduler Is Active)
	Schedule Time & Date Selection (1-16)	Press  to begin editing then  or  when selecting the different parameters in the scheduler.

## 9.2 ACCESSING THE 'RUNNING' CONFIGURATION EDITOR



The 'running' editor can be entered while the engine is running. All protections remain active if the engine is running while the running editor is entered.

Press and hold the  button to enter the running editor.

### 9.2.1 EDITING A PARAMETER

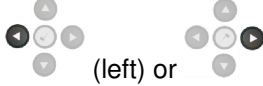
Enter the editor as described above.



Press the  (left) or  (right) buttons to cycle to the section you wish to view/change.





Press the  (up or down) buttons to select the parameter you wish to view/change within the currently selected section.

To edit the parameter, press  to enter edit mode. The parameter begins to flash to indicate that you are editing the value.



Press the  (up or down) buttons to change the parameter to the required value.

Press  to save the value. The parameter ceases flashing to indicate that it has been saved.

To exit the editor at any time, press and hold the  button.

### 9.2.2 ADJUSTABLE PARAMETERS (RUNNING EDITOR)

Running Editor (Factory default settings are shown in bold italicised text)

Section	Parameter as shown on display	Factory Settings
Display	Contrast	53%
	Language	English
	Load parallel power	30%
	Load Power factor	63%
	Commissioning screens	Inactive
	Mains decoupling test mode (Stop mode only)	Inactive
	Voltage adjust (manual mode only engine running breaker open)	0V L-N
	Frequency adjust (manual mode only engine running breaker open)	0 Hz
Auxiliary Mains Fail out of sync reset	Inactive	

## 10 COMMISSIONING

### 10.1.1 PRE-COMMISSIONING

Before the system is started, it is recommended that the following checks are made:-

1. The unit is adequately cooled and all the wiring to the module is of a standard and rating compatible with the system.
2. Check all mechanical parts are fitted correctly and that all electrical connections (including earths) are sound. The unit **DC** supply is fused and connected to the battery and that it is of the correct polarity.
3. Check the operation of the MSC datalink. Use the DSE Config Suite to check this on the SCADA | BUS | MSC LINK page. Verify the number of sets on the bus.
4. Ensure all 8610 controllers in the system have been fully commissioned using the DSE "Four Steps to Successful Synchronising".
5. Place the 8660 module into STOP mode. Place the 8610(s) into AUTO mode. Initiate a start by pressing the START button of the 8660. All 8610's start upon receipt of the MSC start command.
6. The bus will remain off load so long as the mains supply is healthy and on load.
7. Press the 8610 STOP button to remove the start request and stop the set(s).
8. Set the modules internal clock/calendar to ensure correct operation of the scheduler and event logging functions. For details of this procedure see section entitled *Front Panel Configuration – Editing the date and time*.
9. If, despite repeated checking of the connections between the **8600** series controller and the customer's system, satisfactory operation cannot be achieved, then the customer is requested to contact the factory for further advice on:-

**INTERNATIONAL TEL: +44 (0) 1723 890099**

**INTERNATIONAL FAX: +44 (0) 1723 893303**

**E-mail: [Support@Deepseapl.com](mailto:Support@Deepseapl.com)**

**Website : [www.deepseapl.com](http://www.deepseapl.com)**

## 11 FAULT FINDING

SYMPTOM	POSSIBLE REMEDY
Unit is inoperative Read/Write configuration does not operate	Check the battery and wiring to the unit. Check the DC supply. Check the DC fuse.
Unit shuts down	Check DC supply voltage is not above 35 Volts or below 9 Volts Check the operating temperature is not above 70°C. Check the DC fuse.
Continuous starting of generator when in <b>AUTO</b>	Check that there is no signal present on the "Remote Start" input. Check configured polarity is correct. Check the mains supply is available and within configured limits.
Generators fail to start on receipt of Remote Start signal.	Check Start Delay timer has timed out.  Check signal is on "Remote Start" input. Confirm correct configuration of input is configured to be used as "Remote Start".  Check MSC link operation  Check 8660 ATS and 8610 engine controllers are in AUTO mode.
Module appears to 'revert' to an earlier configuration	When editing a configuration using the PC software it is vital that the configuration is first 'read' from the controller before editing it. This edited configuration must then be "written" back to the controller for the changes to take effect.  When editing a configuration using the fascia editor, be sure to press the Accept  button to save the change before moving to another item or exiting the fascia editor
Bus will not take load	Ensure the generator available LED is lit  Check that the output configuration is correct to drive the load switch device and that all connections are correct.  Remember that the set will not take load in manual mode unless the mains supply fails, a remote start on load input is present or the close generator button is pressed.
Inaccurate measurements on controller display	Check that the CT primary, CT secondary and VT ratio settings are correct for the application.  Check that the CTs are wired correctly with regards to the direction of current flow (p1,p2 and s1,s2) and additionally ensure that CTs are connected to the correct phase (errors will occur if CT1 is connected to phase 2).  Remember to consider the power factor. $I_e (kW) = kVA \times \text{powerfactor}$  The 8600 series controller is true RMS measuring so gives more accurate display when compared with an 'averaging' meter such as an analogue panel meter or some lower specified digital multimeters.  Accuracy of the controller is better than 1% of full scale. $I_e$ Gen volts full scale is 333V ph-n so accuracy is $\pm 3.33V$ (1% of 333V).

 **NOTE: The above fault finding is provided as a guide check-list only. As the module can be configured to provide a wide range of different features, always refer to the source of your module configuration if in doubt.**

## 12 MAINTENANCE, SPARES, REPAIR AND SERVICING

The DSE8600 Series controller is designed to be *Fit and Forget*. As such, there are no user serviceable parts within the controller.









In the case of malfunction, you should contact your original equipment supplier (OEM).

### 12.1.1.1 PACK OF PLUGS

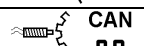
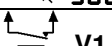
If you require additional plugs from DSE, please contact our Sales department using the part numbers below.

Module type	Plug Pack Part Number
DSE8610	057-513
DSE8660	007-514

### 12.1.1.2 INDIVIDUAL PLUGS

8600 series terminal designation	Plug description	Part No.
1-11 	11 way 5.08mm	007-451
15-19 	Not fitted to DSE8660	
22-30 	9 way 5.08mm	007-167
39-46 	8 way 7.62mm	007-454
47-50 	4 way 7.62mm	007-171
51-56 	6 way 5.08mm	007-446
60-67 	8 way 5.08mm	007-164
RS485 	3 way 5.08mm	007-174
	PC Configuration interface lead (USB type A – type B)	016-125

## 12.2 PURCHASING ADDITIONAL FIXING CLIPS FROM DSE

Item	Description	Part No.
	8600 series fixing clips (packet of 4)	020-294

## 12.3 PURCHASING ADDITIONAL SEALING GASKET FROM DSE

Item	Description	Part No.
	8600 series silicon sealing gasket	020-507









## 12.4 EXPANSION MODULES

**NOTE:** A maximum of twenty (20) expansion modules can be connected to the DSEnet®.

**NOTE:** DSEnet® utilises an RS485 connection. Using Belden 9841 (or equivalent) cable allows for the expansion cable to be extended to a maximum of 1.2km.

DSE Stock and supply Belden 9841 cable. DSE Part Number 016-030.

Item	Max No. supported	Description	Model order number	DSE Part numbers		
				Sales literature	Operator manual	Installation Instructions
	4	Model DSE2130 expansion input module provides additional analogue and digital inputs for use with the 73x0 controller	2130-001-00	055-060	057-082	053-033
	4	Model DSE2131 Ratio-metric input expansion module provides additional resistive, digital, voltage 0-10 V and current 4-20 mA inputs for use with the controller.	2131-001-00	055-115	057-139	053-125
	4	Model DSE2133 RTD/Thermocouple input expansion module provides additional RTD and thermocouple inputs for use with the controller.	2133-001-00	055-114	057-140	053-126
	4	Model DSE2152 Ratio-metric output expansion module provides additional voltage 0-10 V and current 4-20 mA outputs for use with the controller.	2152-001-00	055-112	057-141	053-134
	10	Model DSE2157 expansion relay module provides eight additional voltage free relays for use with the 73x0 controller	2157-001-00	055-061	057-083	053-034
	10	Model DSE2548 expansion LED module provides additional LED indications, internal sounder and remote lamp test/alarm mute for use with the 73x0 controller.	2548-001-00	055-062	057-084	053-032

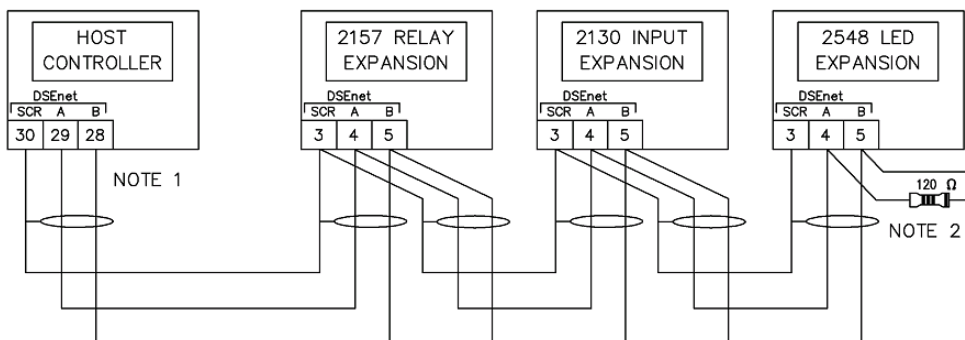

NOTE 1  
AS A TERMINATING RESISTOR IS INTERNALLY FITTED TO THE HOST CONTROLLER, THE HOST CONTROLLER MUST BE THE FIRST UNIT ON THE DSEnet

NOTE 2  
A 120 OHM TERMINATION RESISTOR MUST BE FITTED TO THE LAST UNIT ON THE DSEnet

## 13 WARRANTY

DSE provides limited warranty to the equipment purchaser at the point of sale. For full details of any applicable warranty, you are referred to your original equipment supplier (OEM).

## 14 DISPOSAL

### 14.1 WEEE (WASTE ELECTRICAL AND ELECTRONIC EQUIPMENT)

Directive 2002/96/EC

If you use electrical and electronic equipment you must store, collect, treat, recycle and dispose of WEEE separately from your other waste.



### 14.2 ROHS (RESTRICTION OF HAZARDOUS SUBSTANCES)

Directive 2002/95/EC:2006

To remove specified hazardous substances (Lead, Mercury, Hexavalent Chromium, Cadmium, PBB & PBDE's)

Exemption Note: Category 9. (Monitoring & Control Instruments) as defined in Annex 1B of the WEEE directive will be exempt from the RoHS legislation. This was confirmed in the August 2005 UK's Department of Trade and Industry RoHS REGULATIONS Guide (Para 11).

Despite this exemption, DSE has been carefully removing all non RoHS compliant components from our supply chain and products.

When this is completed a Lead Free & RoHS compatible manufacturing process will be phased into DSE production.

This is a process that is almost complete and is being phased through different product groups.

This page is intentionally left blank

This page is intentionally left blank