



DEEP SEA ELECTRONICS PLC DSE8610 Operator Manual

Document Number: 057-115

Author: Anthony Manton

Deep Sea Electronics Plc
 Highfield House
 Hunmanby
 North Yorkshire
 YO14 0PH
 ENGLAND



Sales Tel: +44 (0) 1723 890099
 Sales Fax: +44 (0) 1723 893303

E-mail: sales@deepseapl.com
 Website: www.deepseapl.com

DSE8610 Operator Manual

© Deep Sea Electronics Plc

All rights reserved. No part of this publication may be reproduced in any material form (including photocopying or storing in any medium by electronic means or other) without the written permission of the copyright holder except in accordance with the provisions of the Copyright, Designs and Patents Act 1988.

Applications for the copyright holder's written permission to reproduce any part of this publication should be addressed to Deep Sea Electronics Plc at the address above.

The DSE logo is a UK registered trademark of Deep Sea Electronics PLC.

Any reference to trademarked product names used within this publication is owned by their respective companies.

Deep Sea Electronics Plc reserves the right to change the contents of this document without prior notice.

Amendments since last publication

Issue no.	Comments
1	First Release
2	Added ROCOF & Vector shift
3	Added Ethernet
4	Added 'MSC OLD UNITS ON BUS' alarm description
5	Added Data logging
6	V5.0 Added Dead Bus synchronising V5.1 V5.1 Added MSC compatibility with 55xx and 75xx series modules Increase configurable Gencon (Derived information) PLC added more Nodes 200-to- 400 / Number of PLC Timers & PLC Counters increased 10-to-20, Output sources- every alarm and input now has equivalent outputs. Control by SMS messages , Remote start off/on load / cancel , Put into stop mode, put into Auto mode. Added extended SMS message to include oil pressure, coolant temp and engine hours run Option to send SMS message as an alarm/flash message, Fuel level SMS Messages Logging Starts / stops in the event log Added new feature to Start Next Set on Warning Added Configurable Editor Screens
7	V6.0 Added Cool Down in Stop Mode and Maintenance Reset on Module Front Panel
8	Updated to suit 8610 V6.3 additions
9	Updated for module firmware V7.0

Clarification of notation used within this publication.



	NOTE:	Highlights an essential element of a procedure to ensure correctness.
	CAUTION!	Indicates a procedure or practice, which, if not strictly observed, could result in damage or destruction of equipment.
	WARNING!	Indicates a procedure or practice, which could result in injury to personnel or loss of life if not followed correctly.

TABLE OF CONTENTS

Section	Page
1 BIBLIOGRAPHY	7
1.1 INSTALLATION INSTRUCTIONS	7
1.2 TRAINING GUIDES.....	7
1.3 MANUALS	7
2 INTRODUCTION	8
3 SPECIFICATIONS	9
3.1 TERMINAL SPECIFICATION.....	9
3.2 POWER SUPPLY REQUIREMENTS.....	9
3.2.1 PLANT SUPPLY INSTRUMENTATION DISPLAY	9
3.3 GENERATOR AND BUS VOLTAGE / FREQUENCY SENSING	10
3.4 GENERATOR CURRENT SENSING	11
3.4.1 VA RATING OF THE CTS.....	11
3.4.2 CT POLARITY	12
3.4.3 CT PHASING.....	12
3.4.4 CT CLASS	12
3.5 INPUTS.....	13
3.5.1 DIGITAL INPUTS	13
3.5.2 ANALOGUE RESISTIVE INPUTS.....	13
3.5.2.1 OIL PRESSURE.....	13
3.5.2.2 COOLANT TEMPERATURE.....	13
3.5.2.3 FLEXIBLE SENSOR	14
3.5.3 ANALOGUE FLEXIBLE INPUT	14
3.5.3.1 FLEXIBLE SENSOR AS DIGITAL.....	14
3.5.3.2 FLEXIBLE SENSOR AS RESISTIVE	14
3.5.4 CHARGE FAIL INPUT	15
3.5.5 MAGNETIC PICKUP	15
3.6 OUTPUTS.....	16
3.6.1 OUTPUTS A & B	16
3.6.2 OUTPUTS C & D.....	16
3.6.2.1 CONTACTOR COILS.....	16
3.6.2.2 UNDERVOLTAGE (UV COILS)	16
3.6.2.3 CLOSING COILS	17
3.6.2.4 OPENING COILS / SHUNT TRIP COILS	17
3.6.2.5 OUTPUTS E,F,G,H, I & J.....	17
3.7 COMMUNICATION PORTS.....	18
3.8 COMMUNICATION PORT USAGE.....	18
3.8.1 CAN INTERFACE.....	18
3.8.2 USB CONNECTION	19
3.8.3 USB HOST-MASTER (USB DRIVE CONNECTION)	19
3.8.4 RS232.....	20
3.8.4.1 RECOMMENDED EXTERNAL MODEMS:	21
3.8.5 RS485.....	22
3.8.6 MSC.....	23
3.8.7 ETHERNET	23
3.8.8 DIRECT PC CONNECTION.....	24
3.8.9 CONNECTION TO BASIC ETHERNET	25
3.8.10 CONNECTION TO COMPANY INFRASTRUCTURE ETHERNET	26
3.8.11 CONNECTION TO THE INTERNET	27
3.8.12 DSENET® FOR EXPANSION MODULES.....	29
3.8.13 DSENET® USED FOR MODBUS ENGINE CONNECTION.....	29
3.9 SOUNDER	30
3.9.1 ADDING AN EXTERNAL SOUNDER TO THE APPLICATION	30
3.10 ACCUMULATED INSTRUMENTATION	30

3.11	DIMENSIONS AND MOUNTING	31
3.11.1	DIMENSIONS.....	31
3.11.2	PANEL CUTOUT.....	31
3.11.3	WEIGHT.....	31
3.11.4	FIXING CLIPS.....	32
3.11.5	CABLE TIE FIXING POINTS.....	33
3.11.6	SILICON SEALING GASKET.....	33
3.12	APPLICABLE STANDARDS	34
3.12.1	ENCLOSURE CLASSIFICATIONS.....	35
3.12.2	NEMA CLASSIFICATIONS.....	36
4	INSTALLATION	37
4.1	TERMINAL DESCRIPTION	37
4.1.1	DC SUPPLY, FUEL AND START OUTPUTS.....	37
4.1.2	ANALOGUE SENSORS.....	38
4.1.3	MAGNETIC PICKUP, CAN AND EXPANSION.....	39
4.1.4	LOAD SWITCHING AND GENERATOR VOLTAGE SENSING.....	40
4.1.5	BUS SENSING.....	40
4.1.6	GENERATOR CURRENT TRANSFORMERS.....	41
4.1.7	CONFIGURABLE DIGITAL INPUTS.....	43
4.1.8	PC CONFIGURATION INTERFACE CONNECTOR.....	43
4.1.9	RS485 CONNECTOR.....	44
4.1.10	RS232 CONNECTOR.....	44
4.2	TYPICAL WIRING DIAGRAMS	45
4.2.1	3 PHASE, 4 WIRE WITH RESTRICTED EARTH FAULT PROTECTION.....	46
4.2.2	3 PHASE, 4 WIRE WITHOUT EARTH FAULT PROTECTION.....	47
4.2.3	3 PHASE 4 WIRE WITH UNRESTRICTED EARTH FAULT PROTECTION.....	48
4.2.4	EARTH SYSTEMS.....	49
4.2.4.1	NEGATIVE EARTH.....	49
4.2.4.2	POSITIVE EARTH.....	49
4.2.4.3	FLOATING EARTH.....	49
4.3	ALTERNATIVE TOPOLOGIES	50
4.3.1	SINGLE PHASE WITH RESTRICTED EARTH FAULT.....	50
4.3.2	SINGLE PHASE WITHOUT EARTH FAULT.....	51
4.3.3	2 PHASE (L1 & L2) 3 WIRE WITH RESTRICTED EARTH FAULT.....	52
4.3.4	2 PHASE (L1 & L2) 3 WIRE WITHOUT EARTH FAULT.....	53
4.3.5	2 PHASE (L1 & L3) 3 WIRE WITH RESTRICTED EARTH FAULT.....	54
4.3.6	2 PHASE (L1 & L3) 3 WIRE WITHOUT EARTH FAULT MEASURING.....	55
4.4	TYPICAL ARRANGEMENT OF DSENET®	56
5	DESCRIPTION OF CONTROLS	57
5.1	DSE8610 AUTOSTART CONTROL MODULE	57
5.2	QUICKSTART GUIDE	59
5.2.1	STARTING THE ENGINE.....	59
5.2.2	STOPPING THE ENGINE.....	59
5.3	VIEWING THE INSTRUMENT PAGES	60
5.3.1	STATUS.....	61
5.3.2	CONFIGURABLE EDITOR SCREENS.....	62
5.3.3	ENGINE.....	63
5.3.4	GENERATOR.....	64
5.3.5	BUS.....	64
5.3.6	RS232 SERIAL PORT.....	65
5.3.7	RS485 SERIAL PORT.....	68
5.3.8	ABOUT.....	69
5.3.8.1	ETHERNET PAGES.....	69
5.3.8.2	DATA LOGGING PAGES.....	70
5.3.9	CAN ERROR MESSAGES.....	71
5.4	VIEWING THE EVENT LOG	72
5.5	USER CONFIGURABLE INDICATORS	73
5.6	CONTROLS	74

6	OPERATION	75
6.1	ALTERNATIVE CONFIGURATIONS	75
6.2	DUMMY LOAD / LOAD SHEDDING CONTROL	76
6.2.1	DUMMY LOAD CONTROL	76
6.2.2	LOAD SHEDDING CONTROL	77
6.3	SMS CONTROL	78
6.4	STOP MODE	78
6.4.1	ECU OVERRIDE	80
6.5	AUTOMATIC MODE	81
6.5.1	WAITING IN AUTO MODE	81
6.5.2	STARTING SEQUENCE	81
6.5.3	ENGINE RUNNING	82
6.5.4	STOPPING SEQUENCE	82
6.6	MANUAL MODE	83
6.6.1	WAITING IN MANUAL MODE	83
6.6.2	STARTING SEQUENCE	83
6.6.3	ENGINE RUNNING	84
6.6.4	MANUAL FUEL PUMP CONTROL	84
6.6.5	MANUAL SPEED CONTROL	85
6.6.6	STOPPING SEQUENCE	85
7	DEAD BUS SYNCHRONISING (AUTO MODE)	86
7.1	OPERATION	86
7.2	DEAD BUS SYNCHRONISING	87
7.3	HARDWARE REQUIREMENTS	87
8	PROTECTIONS	88
8.1	PROTECTIONS DISABLED	89
8.1.1	INDICATION / WARNING ALARMS	89
8.1.2	SHUTDOWN / ELECTRICAL TRIP ALARMS	89
8.2	INDICATIONS	90
8.3	WARNINGS	91
8.4	HIGH CURRENT WARNING ALARM	92
8.5	SHUTDOWNS	93
8.6	ELECTRICAL TRIPS	95
8.7	OVER CURRENT ALARM	97
8.7.1	IMMEDIATE WARNING	97
8.7.2	IDMT ALARM	97
8.8	SHORT CIRCUIT AND EARTH FAULT ALARM	99
8.8.1	EARTH FAULT TRIPPING CURVES	100
8.8.2	SHORT CIRCUIT TRIPPING CURVES	101
8.9	ROCOF / VECTOR SHIFT	102
9	MAINTENANCE ALARM	103
10	SCHEDULER	105
10.1	STOP MODE	105
10.2	MANUAL MODE	105
10.3	AUTO MODE	105
11	FRONT PANEL CONFIGURATION	106
11.1	ACCESSING THE MAIN FRONT PANEL CONFIGURATION EDITOR	107
11.1.1	EDITING A PARAMETER	108
11.1.2	ADJUSTABLE PARAMETERS	109
11.2	ACCESSING THE 'RUNNING' CONFIGURATION EDITOR	110
11.2.1	EDITING A PARAMETER	110
11.2.2	ADJUSTABLE PARAMETERS (RUNNING EDITOR)	110
12	COMMISSIONING	111
12.1	PRE-COMMISSIONING	111

13	FAULT FINDING	112
14	DSE 4 STEPS TO SUCCESSFUL SYNCHRONISING	114
14.1	CONTROL	114
14.2	METERING	114
14.3	COMMUNICATIONS	114
14.4	SYNC CHECKS	114
15	MAINTENANCE, SPARES, REPAIR AND SERVICING	115
15.1	PURCHASING ADDITIONAL CONNECTOR PLUGS FROM DSE	115
15.1.1	PACK OF PLUGS	115
15.1.2	INDIVIDUAL PLUGS	115
15.2	PURCHASING ADDITIONAL FIXING CLIPS FROM DSE	115
15.3	PURCHASING ADDITIONAL SEALING GASKET FROM DSE	115
15.4	DSENET EXPANSION MODULES	116
16	WARRANTY	117
17	DISPOSAL	117
17.1	WEEE (WASTE ELECTRICAL AND ELECTRONIC EQUIPMENT)	117

1 BIBLIOGRAPHY

This document refers to and is referred to by the following DSE publications which can be obtained from the DSE website www.deepseapl.com

1.1 INSTALLATION INSTRUCTIONS

Installation instructions are supplied with the product in the box and are intended as a 'quick start' guide only.

DSE PART	DESCRIPTION
053-069	DSE8610 Installation Instructions
053-129	DSE8620 Installation Instructions
053-070	DES8660 Installation Instructions
053-032	DSE2548 LED Expansion Annunciator Installation Instructions
053-033	DSE2130 Input Expansion Installation Instructions
053-034	DSE2157 Output Expansion Installation Instructions
053-125	DSE2131 Ratio-metric Input Expansion Installation Instructions
053-126	DSE2133 RTD/Thermocouple Input Expansion Installation Instructions
053-134	DSE2152 Ratio-metric Output Expansion Installation Instructions

1.2 TRAINING GUIDES

Training Guides are produced to give 'handout' sheets on specific subjects during training sessions.

DSE PART	DESCRIPTION
056-005	Using CTs With DSE Products
056-006	Introduction to Comms
056-010	Overcurrent Protection
056-013	Load Demand Scheme
056-018	Negative Phase Sequence
056-019	Earth Fault Protection
056-020	Loss of Excitation
056-021	Mains Decoupling
056-022	Breaker Control
056-023	Adding New CAN Files
056-024	GSM Modem
056-026	kW & kVAr
056-029	Smoke Limiting
056-030	Module PIN Codes
056-032	xx60 With No Bus Breaker
056-042	Bus or Mains Mode
056-057	SW1 and SW2
056-059	xx10 in Fixed Export

1.3 MANUALS

DSE PART	DESCRIPTION
057-004	Electronic Engines And DSE Wiring Manual
057-082	DSE2130 Input Expansion Manual
057-083	DSE2157 Output Expansion Manual
057-139	DSE2131 Ratio-metric Input Expansion Manual
057-140	DSE2133 RTD/Thermocouple Expansion Manual
057-141	DSE2152 Ratio-metric Output Expansion Manual
057-084	DSE2548 Annunciator Expansion Manual
057-119	DSE8600 Series Configuration Software Manual
057-120	DSE8660 ATS Operator Manual

2 INTRODUCTION

This document details the installation and operation requirements of the DSE8610 Series modules, part of the DSEPower® range of products.

The manual forms part of the product and should be kept for the entire life of the product. If the product is passed or supplied to another party, ensure that this document is passed to them for reference purposes.

This is not a *controlled document*. You will not be automatically informed of updates. Any future updates of this document will be included on the DSE website at www.deepseapl.com

The **DSE8600 series** is designed to provide differing levels of functionality across a common platform. This allows the generator OEM greater flexibility in the choice of controller to use for a specific application.

The **DSE8600 series** module has been designed to allow the operator to start and stop the generator, and if required, transfer the load to the generator either manually (via fascia mounted push-buttons) or automatically.

Synchronising and Load Sharing features are included within the controller, along with the necessary protections for such a system.

The user also has the facility to view the system operating parameters via the LCD display.

The **DSE8600** module monitors the engine, indicating the operational status and fault conditions, automatically shutting down the engine and giving a true first up fault condition of an engine failure by a COMMON AUDIBLE ALARM. The LCD display indicates the fault.

The powerful ARM microprocessor contained within the module allows for incorporation of a range of complex features:

- *Text based LCD display (supporting multiple languages).*
- **True RMS** Voltage, Current and Power monitoring.
- *Engine parameter monitoring.*
- *Fully configurable inputs for use as alarms or a range of different functions.*
- *Engine ECU interface to **electronic engines**.*
- *Direct connection to governor / AVR for synchronising and load sharing*
- *R.O.C.O.F. and Vector shift for detection of mains failure when in parallel with the mains supply.*

Using a PC and the Configuration Suite software allows alteration of selected operational sequences, timers and alarms.

Additionally, the module's integral fascia configuration editor allows adjustment of a subset of this information.

A robust plastic case designed for front panel mounting houses the module. Connections are via locking plug and sockets.

3 SPECIFICATIONS

3.1 TERMINAL SPECIFICATION

Connection type	Two part connector. <ul style="list-style-type: none"> • Male part fitted to module • Female part supplied in module packing case - Screw terminal, rising clamp, no internal spring. 	 <p>Example showing cable entry and screw terminals of a 10 way connector</p>
Minimum cable size	0.5mm ² (AWG 24)	
Maximum cable size	2.5mm ² (AWG 10)	

NOTE: For purchasing additional connector plugs from DSE, please see the section entitled *Maintenance, Spares, Repair and Servicing* elsewhere in this document.

3.2 POWER SUPPLY REQUIREMENTS

Minimum supply voltage	8V continuous
Cranking dropouts	<p>Able to survive 0V for 50mS providing the supply was at least 10V before the dropout and recovers to 5V afterwards.</p> <p>This is more than sufficient to allow the module to operate during engine cranking where the battery supply often falls as low as 4V (on a 12V system!)</p> <p>This is achieved without the need for internal batteries or other external requirements.</p>
Maximum supply voltage	35V continuous (60V protection for surges)
Reverse polarity protection	-35V continuous
Maximum operating current	<p>300mA at 24V</p> <p>600mA at 12V</p>
Maximum standby current	<p>190mA at 24V</p> <p>390mA at 12V</p>

3.2.1 PLANT SUPPLY INSTRUMENTATION DISPLAY

Range	0V-70V DC (note Maximum continuous operating voltage of 35V DC)
Resolution	0.1V
Accuracy	±1% full scale (±0.7V)

3.3 GENERATOR AND BUS VOLTAGE / FREQUENCY SENSING

Measurement type	True RMS conversion
Sample Rate	5KHz or better
Harmonics	Up to 10 th or better
Input Impedance	300K Ω ph-N
Phase to Neutral	15V (minimum required for sensing frequency) to 333V AC (absolute maximum) Suitable for 110V to 277V nominal ($\pm 20\%$ for under/overvoltage detection)
Phase to Phase	26V (minimum required for sensing frequency) to 576V AC (absolute maximum) Suitable for 190V ph-ph to 479V ph-ph nominal ($\pm 20\%$ for under/overvoltage detection)
Common mode offset from Earth	100V AC (max)
Resolution	1V AC phase to neutral 2V AC phase to phase
Accuracy	$\pm 1\%$ of full scale phase to neutral ($\pm 3.33V$ ph-N) $\pm 2\%$ of full scale phase to phase ($\pm 11.52V$ ph-ph)
Minimum frequency	3.5Hz
Maximum frequency	75.0Hz
Frequency resolution	0.1Hz
Frequency accuracy	$\pm 0.2Hz$

3.4 GENERATOR CURRENT SENSING

Measurement type	True RMS conversion
Sample Rate	5KHz or better
Harmonics	Up to 10 th or better
Nominal CT secondary rating	1A or 5A (5A recommended)
Maximum continuous current	5A
Overload Measurement	3 x Nominal Range setting
Absolute maximum overload	50A for 1 second
Burden	0.5VA (0.02Ω current shunts)
common mode offset	±2V peak plant ground to CT common terminal
Resolution	0.5% of 5A
Accuracy	±1% of Nominal (1A or 5A) (excluding CT error)

3.4.1 VA RATING OF THE CTS

The VA burden of the DSE8610 module on the CTs is 0.5VA. However depending upon the type and length of cabling between the CTs and the DSE8610 module, CTs with a greater VA rating than the module are required.

The distance between the CTs and the measuring module should be estimated and cross-referenced against the chart opposite to find the VA burden of the cable itself.

If the CTs are fitted within the alternator top box, the star point (common) of the CTs should be connected to system ground (earth) as close as possible to the CTs. This minimises the length of cable used to connect the CTs to the DSE module.

Example.

If 1.5mm² cable is used and the distance from the CT to the measuring module is 20m, then the burden of the cable alone is approximately 15VA. As the burden of the DSE controller is 0.5VA, then a CT with a rating of at least 15+0.5V = 15.5VA must be used. If 2.5mm² cables are used over the same distance of 20m, then the burden of the cable on the CT is approximately 7VA. CT's required in this instance is at least 7.5VA (7+0.5).

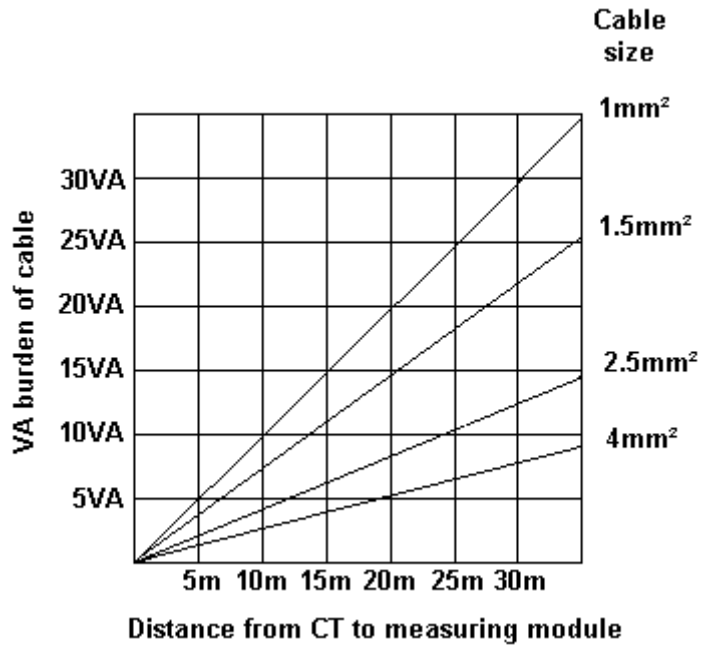

NOTE: Details for 4mm² cables are shown for reference only. The connectors on the DSE modules are only suitable for cables up to 2.5mm².

NOTE: CTs with 5A secondary windings are recommended with DSE modules. 1A CTs can be used if necessary however, the resolution of the readings is 5 times better when using 5A CTs.

3.4.2 CT POLARITY

Take care to ensure the correct polarity of the CTs. Incorrect CT orientation will lead to negative kW readings when the set is supplying power. Take note that paper stick-on labels on CTs that show the orientation are often incorrectly placed on the CT (!). It is more reliable to use the labelling in the case moulding as an indicator to orientation (if available).

To test orientation, run the generator in island mode (not in parallel with any other supply) and load the generator to around 10% of the set rating. Ensure the DSE module shows positive kW for all three individual phase readings.

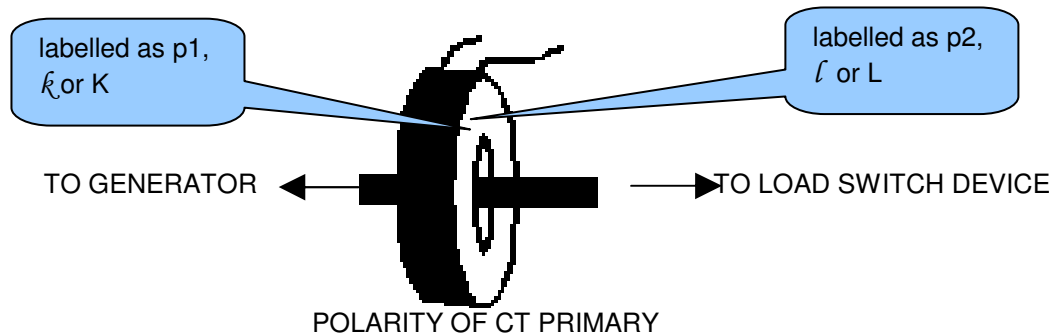

NOTE: Take care to ensure correct polarity of the CT primary as shown above. If in doubt, check with the CT supplier.

3.4.3 CT PHASING

Take particular care that the CTs are connected to the correct phases. For instance, ensure that the CT on phase 1 is connected to the terminal on the DSE module intended for connection to the CT for phase 1.

Additionally ensure that the voltage sensing for phase 1 is actually connected to generator phase 1. Incorrect connection of the phases as described above will result in incorrect power factor (pf) measurements, which in turn results in incorrect kW measurements.

One way to check for this is to make use of a single-phase load. Place the load on each phase in turn, run the generator and ensure the kW value appears in the correct phase. For instance if the load is connected to phase 3, ensure the kW figure appears in phase 3 display and not in the display for phase 1 or 2.

3.4.4 CT CLASS

Ensure the correct CT type is chosen. For instance if the DSE module is providing overcurrent protection, ensure the CT is capable of measuring the overload level you wish to protect against, and at the accuracy level you require.

For instance, this may mean fitting a protection class CT (P10 type) to maintain high accuracy while the CT is measuring overload currents.

Conversely, if the DSE module is using the CT for instrumentation only (current protection is disabled or not fitted to the controller), then measurement class CTs can be used. Again, bear in mind the accuracy you require. The DSE module is accurate to better than 1% of the full-scale current reading. To maintain this accuracy you should fit Class 0.5 or Class 1 CTs.

You should check with your CT manufacturer for further advice on selecting your CTs

3.5 INPUTS

3.5.1 DIGITAL INPUTS

Number	11 configurable inputs
Arrangement	Contact between terminal and ground
Low level threshold	2.1V minimum
High level threshold	6.6V maximum
Maximum input voltage	+50V DC with respect to plant supply negative
Minimum input voltage	-24V DC with respect to plant supply negative
Contact wetting current	7mA typical
Open circuit voltage	12V typical

3.5.2 ANALOGUE RESISTIVE INPUTS

3.5.2.1 OIL PRESSURE

Configurable if engine ECU link provides oil pressure measurement

Measurement type	Resistance measurement by measuring voltage across sensor with a fixed current applied
Arrangement	Differential resistance measurement input
Measurement current	15mA
Full scale	240Ω
Over range / fail	270Ω
Resolution	0.1 Bar (1-2 PSI)
Accuracy	±2% of full scale resistance (±4.8Ω) excluding transducer error
Max common mode voltage	±2V
Display range	13.7 bar (0-200 PSI) subject to limits of the sensor

3.5.2.2 COOLANT TEMPERATURE

Configurable if engine ECU link provides coolant temp measurement

Measurement type	Resistance measurement by measuring voltage across sensor with a fixed current applied
Arrangement	Differential resistance measurement input
Measurement current	10mA
Full scale	480Ω
Over range / fail	540Ω
Resolution	1°C (2°F)
Accuracy	+/-2% of full scale resistance (±9.6Ω) excluding transducer error
Max common mode voltage	±2V
Display range	0°C -140°C (32°F - 284 °F) subject to limits of the sensor

3.5.2.3 FLEXIBLE SENSOR

Number	2
Measurement type	Resistance measurement by measuring voltage across sensor with a fixed current applied
Arrangement	Differential resistance measurement input
Measurement current	10mA
Full scale	480Ω
Over range / fail	540Ω
Resolution	1%
Accuracy	±2% of full scale resistance (±9.6Ω) excluding transducer error
Max common mode voltage	±2V
Display range	0-250%

3.5.3 ANALOGUE FLEXIBLE INPUT

An additional flexible analogue input is provided and can be configured as Digital or Resistive.

3.5.3.1 FLEXIBLE SENSOR AS DIGITAL

Arrangement	Contact between input terminal and battery negative
Low level threshold	2.1 V minimum
High level threshold	6.6 V maximum
Max input voltage	+60 V DC with respect to battery negative
Min input voltage	-24 V DC with respect to battery negative
Contact wetting current	7 mA typical
Open circuit voltage	12 V typical

3.5.3.2 FLEXIBLE SENSOR AS RESISTIVE

Arrangement	Differential resistance measurement input with individual common terminals for each sensor input
Measurement current	9.3 mA typical
Full scale	480 Ω
Sensor fail	Values greater than full scale return an over range sentinel that may be interpreted as sensor fail if appropriate (host controller dependant)
Resolution	1% of full scale
Accuracy	±2 % of full scale resistance, excluding transducer (sensor) error
Maximum common mode voltage	3 V
Transducer (sensor type)	Configurable in host controller
Use with contacts	Inputs may be used with a contact to ground providing the corresponding common terminal is grounded. (ie can be used as digital inputs if correctly configured in the host controller)

3.5.4 CHARGE FAIL INPUT

Minimum voltage	0V
Maximum voltage	35V (plant supply)
Resolution	0.2V
Accuracy	±1% of max measured voltage (±0.35V)
Excitation	Active circuit constant power output
Output Power	2.5W Nominal @12V and 24V
Current at 12V	210mA
Current at 24V	104mA

. The charge fail input is actually a combined input and output. Whenever the generator is required to run, the terminal provides excitation current to the charge alternator field winding. When the charge alternator is correctly charging the battery, the voltage of the terminal is close to the plant battery supply voltage. In a failed charge situation, the voltage of this terminal is pulled down to a low voltage. It is this drop in voltage that triggers the *charge failure* alarm. The level at which this operates and whether this triggers a warning or shutdown alarm is configurable using the DSE Config Suite Software.

3.5.5 MAGNETIC PICKUP

Type	Differential input
Minimum voltage	0.5V RMS
Max common mode voltage	±2V
Maximum voltage	Clamped to ±70V by transient suppressors
Maximum frequency	10,000Hz
Resolution	6.25 RPM
Accuracy	±25 RPM
Flywheel teeth	10 to 500

NOTE : DSE can supply a suitable magnetic pickup device, available in two body thread lengths :
DSE Part number 020-012 - Magnetic Pickup probe 5/8 UNF 2½" thread length
DSE Part number 020-013 - Magnetic Pickup probe 5/8 UNF 4" thread length

Magnetic Pickup devices can often be 'shared' between two or more devices. For example, one device can often supply the signal to both the DSE8600 series module and the engine governor. The possibility of this depends upon the amount of current that the magnetic pickup can supply.

3.6 OUTPUTS

Ten (10) digital outputs are fitted to the DSE8610 controller. Additional outputs are provided for by adding up to ten (10) external relay boards (DSE2157). This allows for up to 80 additional digital outputs.

3.6.1 OUTPUTS A & B

Type	Normally used for Fuel / Start outputs. Fully configurable for other purposes if the module is configured to control an electronic engine. Supplied from Emergency Stop terminal 3.
Rating	15A resistive @ 35V

3.6.2 OUTPUTS C & D

Type	Voltage free relays, fully configurable, normally used for generator / mains load switch control.
Rating	8A resistive @ 250 V AC

3.6.2.1 CONTACTOR COILS

Use output D, the normally open relay:

Generator

Close Gen Output Energise

DSE output drives the contactor coil, via external slave relay if required.
 When the DSE module requires the contactor closed, the output energises (closing the internal relay)
 When the DSE module requires the contactor to be open, the output is de-energised (opening the internal relay)

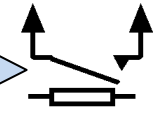

3.6.2.2 UNDERVOLTAGE (UV COILS)

Use output C, the normally closed relay :

Generator

Open Gen Output Pulse Energise

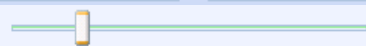
Breaker Trip Pulse 1.0s 

DSE output drives the UV coil, via external slave relay if required.
 When the generator starts, the UV is powered via the normally closed relay. The breaker is now ready for the close signal to be given. When the breaker is to be opened, the Open Generator Pulse relay is operated, removing power from the UV coil for one second. This causes the breaker to trip (open) as the UV is no longer powered. The Open Generator Pulse relay switches back to its closed state, ready to power the UV coil the next time the generator starts.



3.6.2.3 CLOSING COILS

For continuous closing signals (close signal is present continuously when the breaker is closed), follow the instructions above as for *Contactors Coils*.

For momentary (pulsed) closing signals, use OUTPUT D, the normally open relay:

Generator

Close Gen Output Pulse Energise

Breaker Close Pulse 0.5s 

When the DSE module requires the breaker closed, the output energises (closing the internal relay) for the period of the Breaker Close Pulse timer after which the output is de-energised (opening the internal relay).



3.6.2.4 OPENING COILS / SHUNT TRIP COILS

For Continuous opening signal, use output D, the normally open relay:

Generator:

Open Gen Output Energise

When the DSE module requires the breaker open, the output energises (closing the internal relay).



For momentary (pulsed) closing signals, use a normally open relay:

Generator:

Open Gen Output Pulse Energise

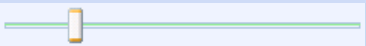
Breaker Trip Pulse 1.0s 

When the DSE module requires the breaker open, the output energises (closing the internal relay) for the period of the *breaker trip pulse*.



3.6.2.5 OUTPUTS E,F,G,H, I & J

Number	6
Type	Fully configurable, supplied from DC supply terminal 2.
Rating	3A resistive @ 35V

3.7 COMMUNICATION PORTS

USB Port	USB2.0 Device for connection to PC running DSE configuration suite only Max distance 6m (yards)
Serial Communication	RS232 and RS485 are both fitted and provide independent operation
RS232 Serial port	Non – Isolated port Max Baud rate 115.2K baud subject to S/W TX, RX, RTS, CTS, DSR, DTR, DCD Male 9 way D type connector Max distance 15m (50 feet)
RS485 Serial port	Isolated Data connection 2 wire + common Half Duplex Data direction control for Transmit (by s/w protocol) Max Baud Rate 115200 External termination required (120Ω) Max common mode offset 70V (on board protection transorb) Max distance 1.2km (¾ mile)
MSC Multi Set Communication Port	Multi Set Communication Port (connection to other DSE modules) Data connection 2 wire + common Isolated External termination required (120Ω) Max common mode offset 70V (on board protection transorb) Max distance 250M using Belden 9841 Cable or equivalent
CAN Port	Engine CAN Port Standard implementation of ‘Slow mode’, up to 250K bits/s Non-Isolated. Internal Termination provided (120Ω) Max distance 40m (133 feet) <div style="border: 1px solid black; padding: 5px; margin-top: 10px;">▲NOTE: For additional length, the DSE124 CAN Extender is available. Please refer to DSE Publication: 057-116 DSE124 Operator Manual for more information.</div>
Ethernet	Auto detecting 10/100 Ethernet port.

3.8 COMMUNICATION PORT USAGE

3.8.1 CAN INTERFACE

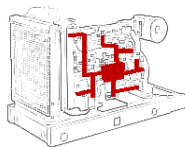

Modules are fitted with the CAN interface as standard and are capable of receiving engine data from engine CAN controllers compliant with the CAN standard.

CAN enabled engine controllers monitor the engine’s operating parameters such as engine speed, oil pressure, engine temperature (among others) in order to closely monitor and control the engine. The industry standard communications interface (CAN) transports data gathered by the engine controller interface. This allows generator controllers such as the DSE8600 series to access these engine parameters with no physical connection to the sensor device.

▲NOTE: For further details for connections to CAN enabled engines and the functions available with each engine type, refer to the manual *Electronic Engines and DSE Wiring*. Part No. 057-004

3.8.2 USB CONNECTION

The USB port is provided to give a simple means of connection between a PC and the DSE8600 series controller.

Using the DSE Configuration Suite Software, the operator is then able to control the module, starting or stopping the generator, selecting operating modes, etc.

Additionally, the various operating parameters (such as output volts, oil pressure, etc.) of the remote generator are available to be viewed or changed.

To connect a DSE8600 series module to a PC by USB, the following items are required:

- DSE8600 series module



- DSE 8600 series configuration software
(Supplied on configuration suite software CD or available from www.deepseapl.com).



- USB cable Type A to Type B.
(This is the same cable as often used between a PC and a USB printer)



DSE can supply this cable if required :
PC Configuration interface lead (USB type A – type B) DSE Part No
016-125

NOTE: The DC supply must be connected to the module for configuration by PC.

NOTE: Refer to DSE8600 series Configuration Suite Manual (DSE part 057-119) for further details on configuring, monitoring and control.

3.8.3 USB HOST-MASTER (USB DRIVE CONNECTION)

Capability to add USB Host facility for USB 'Pendrive' type interface for data recording Connector Type A.

For data logging max maximum size 16Gb.(see viewing the instrument pages)

NOTE: Refer to DSE8600 series Configuration Suite Manual (DSE part 057-119) for further details on configuring, monitoring and control.

3.8.4 RS232

The RS232 port on the DSE8600 series controller supports the Modbus RTU protocol. The Gencomm register table for the controller is available upon request from the DSE Technical Support Department.

RS232 is for short distance communication (max 15m) and is typically used to connect the DSE86xx series controller to a telephone or GSM modem for more remote communications.

Many PCs are not fitted with an internal RS232 serial port. DSE DOES NOT recommend the use of USB to RS232 convertors but can recommend PC add-ons to provide the computer with an RS232 port.

Recommended PC Serial Port add-ons (for computers without internal RS232 port):
Remember to check these parts are suitable for your PC. Consult your PC supplier for further advice.

- Brainboxes PM143 PCMCIA RS232 card (for laptop PCs)
- Brainboxes VX-001 Express Card RS232 (for laptops and nettops PCs)
- Brainboxes UC246 PCI RS232 card (for desktop PCs)
- Brainboxes PX-246 PCI Express 1 Port RS232 1 x 9 Pin (for desktop PCs)



Supplier:

Brainboxes

Tel: +44 (0)151 220 2500

Web: <http://www.brainboxes.com>

Email: Sales:sales@brainboxes.com

NB DSE Have no business tie to Brainboxes. Over many years, our own engineers have used these products and are happy to recommend them.

3.8.4.1 RECOMMENDED EXTERNAL MODEMS:

- Multitech Global Modem – MultiModem ZBA (PSTN)
DSE Part Number 020-252
(Contact DSE Sales for details of localisation kits for these modems)



- Wavecom Fastrak Supreme GSM modem kit (PSU, Antenna and modem)*
DSE Part number 0830-001-01



- Brodersen GSM Industrial Modem*
DSE Part number 020-245



▲ NOTE: *For GSM modems a SIM card is required, supplied by your GSM network provider :

- For SMS only, a 'normal' voice SIM card is required. This enables the controller to send SMS messages to designated mobile phones upon status and alarm conditions.
- For a data connection to a PC running DSE Configuration Suite Software, a 'special' CSD (Circuit Switched Data) SIM card is required that will enable the modem to answer an incoming data call. Many 'pay as you go' services will not provide a CSD (Circuit Switched Data) SIM card.

3.8.5 RS485

The RS485 port on the DSE8600 series controller supports the Modbus RTU protocol. The DSE Gencomm register table for the controller is available upon request from the DSE Technical Support Department.

RS485 is used for point-to-point cable connection of more than one device (maximum 32 devices) and allows for connection to PCs, PLCs and Building Management Systems (to name just a few devices).

One advantage of the RS485 interface is the large distance specification (1.2km when using Belden 9841 (or equivalent) cable. This allows for a large distance between the DSE8600 series module and a PC running the DSE Configuration Suite software. The operator is then able to control the module, starting or stopping the generator, selecting operating modes, etc.

The various operating parameters (such as output volts, oil pressure, etc.) of the remote generator can be viewed or changed.

NOTE: For a single module to PC connection and distances up to 6m (8yds) the USB connection method is more suitable and provides for a lower cost alternative to RS485 (which is more suited to longer distance connections).

Recommended PC Serial Port add-ons (for computers without internal RS485 port). Remember to check these parts are suitable for your PC. Consult your PC supplier for further advice.

- Brainboxes PM154 PCMCIA RS485 card (for laptops PCs)
Set to 'Half Duplex, Autogating" with 'CTS True' set to 'enabled'
- Brainboxes VX-023 ExpressCard 1 Port RS422/485 (for laptops and nettop PCs)
- Brainboxes UC320 PCI Velocity RS485 card (for desktop PCs)
Set to 'Half Duplex, Autogating" with 'CTS True' set to 'enabled'
- Brainboxes PX-324 PCI Express 1 Port RS422/485 (for desktop PCs)



Supplier:

Brainboxes

Tel: +44 (0)151 220 2500

Web: <http://www.brainboxes.com>

Email: Sales;sales@brainboxes.com

NB DSE Have no business tie to Brainboxes. Over many years, our own engineers have used these products and are happy to recommend them.

3.8.6 MSC

The MSC (Multi System control) is used to communicate with other DSE modules in a system.

The MSC is used for point-to-point cable connection of more than one device (maximum 32 Generator controller and another 8 Mains / Bus tie devices giving a maximum of 40 units)

The maximum distance is 250M using Belden 9841, 120ohm impedance screened twisted pair cable. This can be extended using DSE124 Can Bus Extender

NOTE: Version 86xx V 5.0 included a change to the MSC link protocol which is not compatible with lower versions until the lower versions have been upgraded to version 5.0 (This can be done using “Update Firmware” in Configuration Suite Software) .

NOTE: At version 5.1+ The MSC communication changed to enable 86xx ranges to communicate with 55xx and 75xx range of modules.

When using 55xx or 75xx with 86xx the MSC capability lowers to that of the 55xx/ 75xx series. i.e. Max units that can be used together in the case of 55xx,75xx would be 16 generators on the MSC link at any one time, not the 32 Gen sets that the DSE86xx is specified.

3.8.7 ETHERNET

The DSE8610 is fitted with ETHERNET socket for connection to LAN (local area networks)

Description	
1	TX+
2	TX-
3	RX+
4	Do not connect
5	Do not connect
6	RX-
7	Do not connect
8	Do not connect

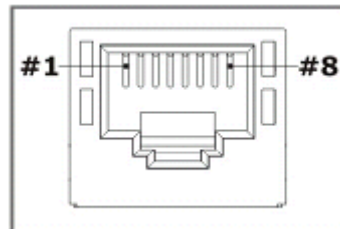

3.8.8 DIRECT PC CONNECTION

Requirements

- DSE8610
- Crossover Ethernet cable (see Below)
- PC with Ethernet port and Windows Internet Explorer 6 or above, Firefox

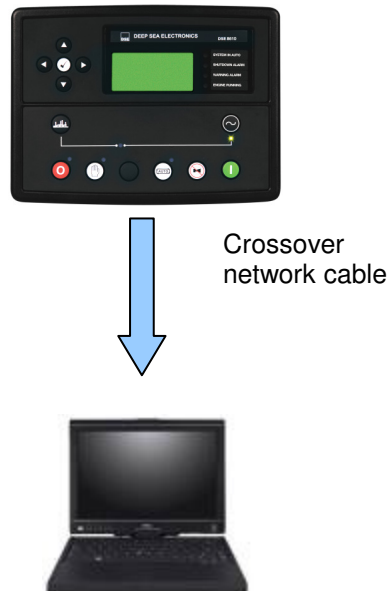

Crossover cable wiring detail

Two pairs crossed, two pairs uncrossed
10baseT/100baseTX crossover

Pin	Connection 1 (T568A)	Connection 2 (T568B)
1	 white/green stripe	 white/orange stripe
2	 green solid	 orange solid
3	 white/orange stripe	 white/green stripe
4	 blue solid	 blue solid
5	 white/blue stripe	 white/blue stripe
6	 orange solid	 green solid
7	 white/brown stripe	 white/brown stripe
8	 brown solid	 brown solid

For the advanced Engineer, a crossover cable is a CAT5 cable with one end terminated as T568A and the other end terminated as T568B.



NOTE: This cable can be purchased from any good PC or IT store.

3.8.9 CONNECTION TO BASIC ETHERNET

Requirements

- DSE8610
- Ethernet cable (see below)
- Working Ethernet (company or home network)
- PC with Ethernet port and Windows Internet Explorer 6 or above, Firefox

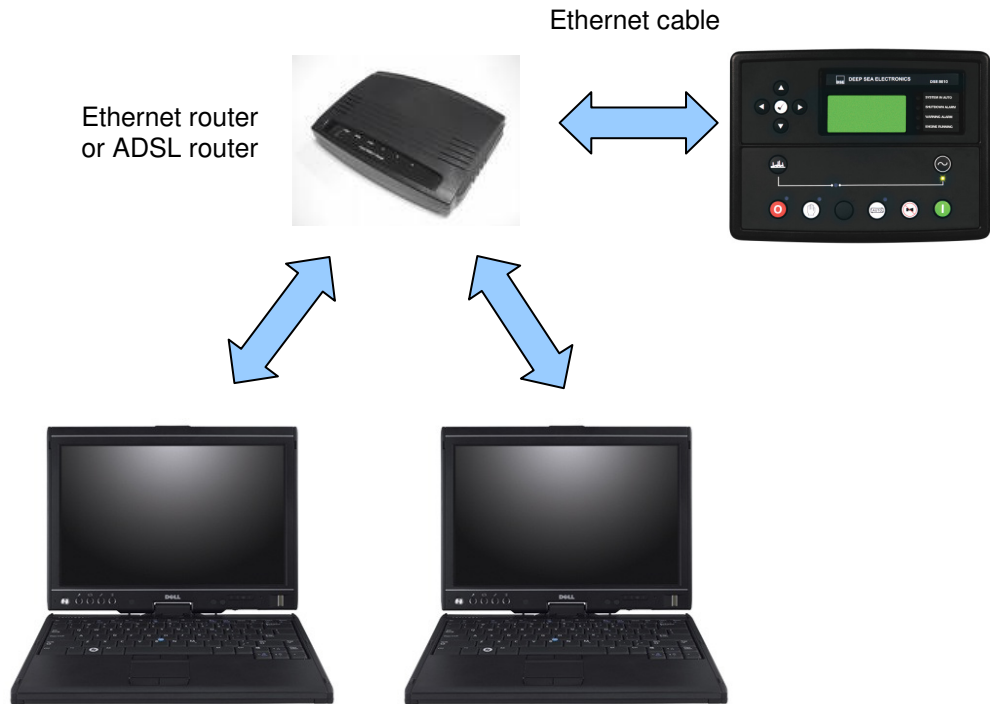

Ethernet cable wiring detail

10baseT/100baseT

Pin	Connection 1 (T568A)	Connection 2 (T568A)
1	white/green stripe	white/green stripe
2	green solid	green solid
3	white/orange stripe	white/orange stripe
4	blue solid	blue solid
5	white/blue stripe	white/blue stripe
6	orange solid	orange solid
7	white/brown stripe	white/brown stripe
8	brown solid	brown solid

For the advanced Engineer, this cable has both ends terminated as T568A (as shown below) or T568B.

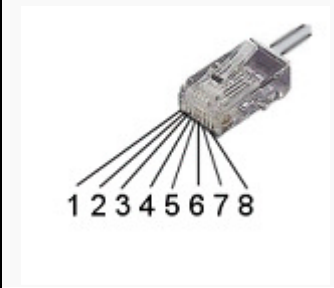

NOTE: DSE Stock a 2m (2yds) Ethernet Cable – Part number 016-137. Alternatively they can be purchased from any good PC or IT store.

3.8.10 CONNECTION TO COMPANY INFRASTRUCTURE ETHERNET





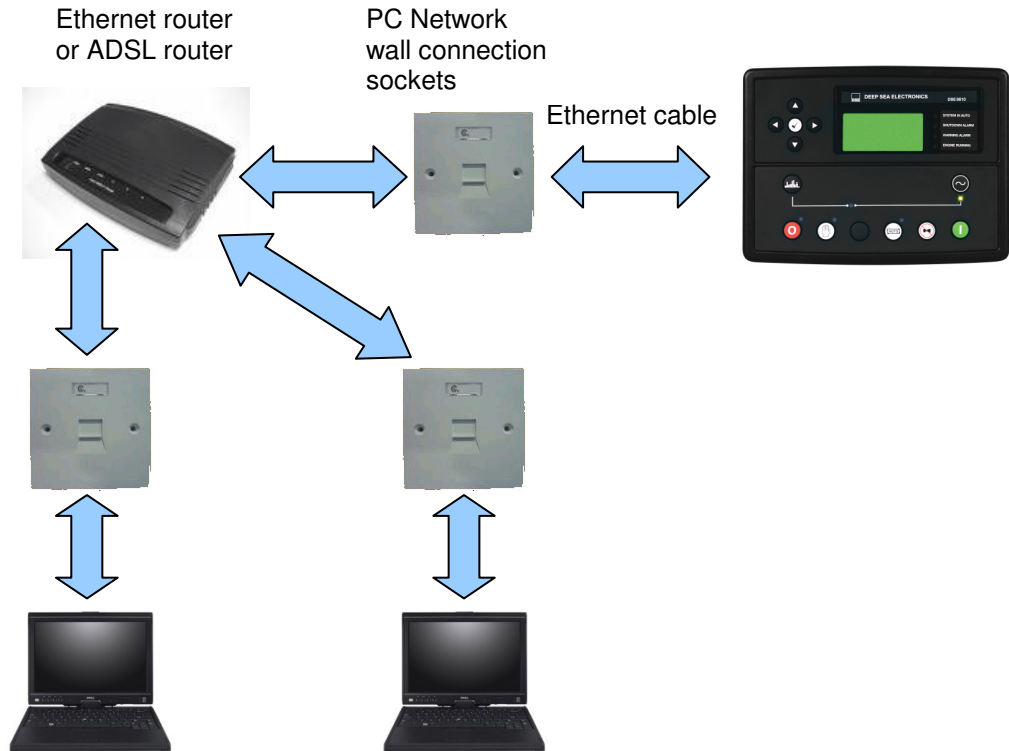











Requirements

- DSE8610
- Ethernet cable (see below)
- Working Ethernet (company or home network)
- PC with Ethernet port and Windows Internet Explorer 6 or above, Firefox



Ethernet cable wiring detail

10baseT/100baseT

Pin	Connection 1 (T568A)	Connection 2 (T568B)
1	 white/green stripe	 white/green stripe
2	 green solid	 green solid
3	 white/orange stripe	 white/orange stripe
4	 blue solid	 blue solid
5	 white/blue stripe	 white/blue stripe
6	 orange solid	 orange solid
7	 white/brown stripe	 white/brown stripe
8	 brown solid	 brown solid

For the advanced Engineer, this cable has both ends terminated as T568A (as shown below) or T568B.

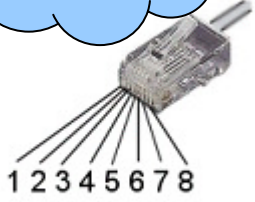

NOTE: DSE Stock a 2m (2yds) Ethernet Cable – Part number 016-137. Alternatively they can be purchased from any good PC or IT store.

3.8.11 CONNECTION TO THE INTERNET

Requirements

- Ethernet cable (see below)
- Working Ethernet (company or home network)
- Working Internet connection (ADSL or DSL recommended)

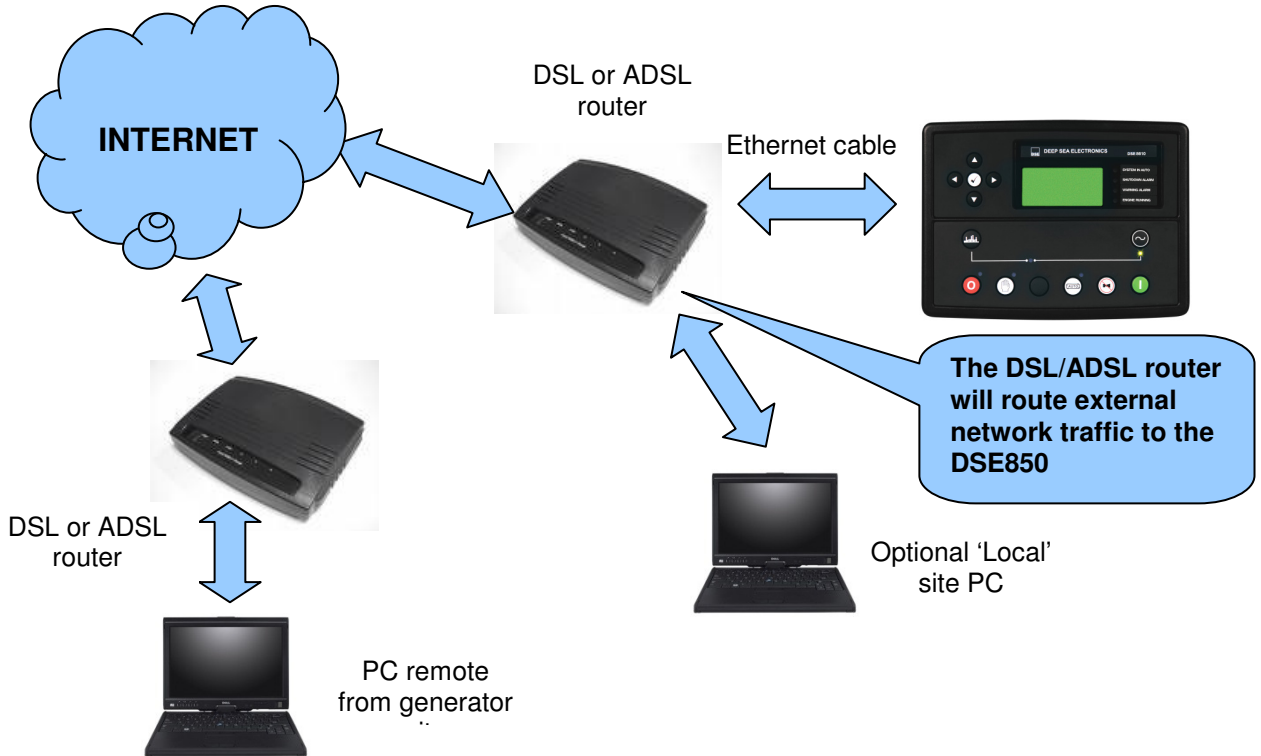

Ethernet cable wiring detail

10baseT/100baseT

Pin	Connection 1 (T568A)	Connection 2 (T568A)
1	white/green stripe	white/green stripe
2	green solid	green solid
3	white/orange stripe	white/orange stripe
4	blue solid	blue solid
5	white/blue stripe	white/blue stripe
6	orange solid	orange solid
7	white/brown stripe	white/brown stripe
8	brown solid	brown solid

For the advanced Engineer, this cable has both ends terminated as T568A (as shown below) or T568B.

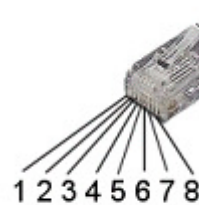

NOTE: DSE Stock a 2m (2yds) Ethernet Cable – Part number 016-137. Alternatively they can be purchased from any good PC or IT store.

Firewall configuration for internet access

As modem/routers differ enormously in their configuration, it is not possible for DSE to give a complete guide to their use with the DSE8610. However it is possible to give a description of the requirements in generic terms. For details of how to achieve the connection to your modem/router you are referred to the supplier of your modem/router equipment.

The DSE8610 makes its data available over Modbus TCP and as such communicates over the Ethernet using a Port configured via the DSE config suite software..

You must configure your modem/router to allow inbound traffic on this port. For more information you are referred to your WAN interface device (modem/router) manufacturer.

It is also important to note that if the port assigned (setting from software "Modbus Port Number") is already in use on the LAN, the DSE8610 cannot be used and another port must be used .

Outgoing Firewall rule

As the DSE8610 makes its user interface available to standard web browsers, all communication uses the chosen port. It is usual for a firewall to make the same port outgoing open for communication.

Incoming traffic (virtual server)

Network Address and Port Translation (NAPT) allows a single device, such as the modem/router gateway, to act as an agent between the Internet (or "public external network") and a local (or "internal private") network. This means that only a single, unique IP address is required to represent an entire group of computers.

For our DSE8610 application, this means that the WAN IP address of the modem/router is the IP address we need to access the site from an external (internet) location.

When requests reaches the modem/router, we want this passed to a 'virtual server' for handling, in our case this is the DSE8610 module.

Result : Traffic arriving from the WAN (internet) on port xxx is automatically sent to IP address set within the configuration software on the LAN (DSE8610) for handling.

 NOTE: Refer to DSE8600 series Configuration Suite Manual (DSE part 057-119) for further details on configuring, monitoring and control.

3.8.12 DSENET® FOR EXPANSION MODULES

DSENet® is the interconnection cable between the host controller and the expansion module(s) and must not be connect to any device other than DSE equipment designed for connection to the DSENet®

Cable type	Two core screened twisted pair
Cable characteristic impedance	120Ω
Recommended cable	Belden 9841 Belden 9271
Maximum cable length	1200m (¾ mile) when using Belden 9841 or direct equivalent. 600m (666 yds) when using Belden 9271 or direct equivalent.
DSENet® topology	“Daisy Chain” Bus with no stubs (spurs)
DSENet® termination	120Ω. Fitted internally to host controller. Must be fitted externally to the ‘last’ expansion module by the customer.
Maximum expansion modules	Total 20 devices made up of DSE2130 (up to 4), DSE2131 (up to 4), DSE2133 (up to 4), DSE2152 (up to 4), DSE2157 (up to 10), DSE2548 (up to 10) This gives the possibility of : Maximum 80 additional relay outputs Maximum 24 analogue outputs Maximum 80 additional LED indicators Maximum 104 additional inputs (16 of which are digital, 56 are analogue or digital if required, and 32 temperature sensor)

NOTE: As a termination resistor is internally fitted to the host controller, the host controller must be the ‘first’ unit on the DSENet®. A termination resistor **MUST** be fitted to the ‘last’ unit on the DSENet®. For connection details, you are referred to the section entitled ‘typical wiring diagram’ elsewhere in this document.

NOTE : DSE8600 series does not support the 2510/2520 display modules.

3.8.13 DSENET® USED FOR MODBUS ENGINE CONNECTION

As DSENet® utilises an RS485 hardware interface, this port can be configured for connection to Cummins Modbus engines (Engines fitted with Cummins GCS). This leaves the RS485 interface free for connection to remote monitoring equipment (i.e. Building Management System, PLC or PC RS485 port).

While this is a very useful feature in some applications, the obvious drawback is that the DSENet® interface is no longer available for connection to expansion devices.

Example of configuring the DSENet® for connection to Cummins QST GCS using the DSE Configuration Suite Software:

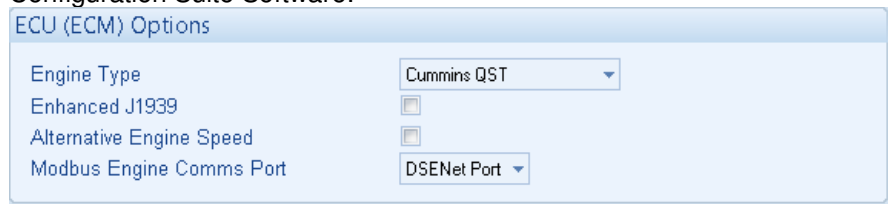

3.9 SOUNDER

DSE8600 Series features an internal sounder to draw attention to warning, shutdown and electrical trip alarms.

Sounder level	64db @ 1m
---------------	-----------

3.9.1 ADDING AN EXTERNAL SOUNDER TO THE APPLICATION

Should an external alarm or indicator be required, this can be achieved by using the DSE Configuration Suite PC software to configure an auxiliary output for “Audible Alarm”, and by configuring an auxiliary input for “Alarm Mute” (if required).

The audible alarm output activates and de-activates at the same time as the module’s internal sounder. The Alarm mute input and internal alarm mute button activate ‘in parallel’ with each other. Either signal will mute both the internal sounder and audible alarm output.

Example of configuration to achieve external sounder with external alarm mute button:

The screenshot shows two configuration windows. The first window, titled "Relay Outputs (DC Supply Out)", has a table with the following data:

Output	Source	Polarity
Output E	Audible Alarm	Energise

The second window, titled "Digital Input A", has a table with the following data:

Function
Alarm Mute

3.10 ACCUMULATED INSTRUMENTATION

NOTE: When an accumulated instrumentation value exceeds the maximum number as listed below, it will reset and begin counting from zero again.

Engine hours run	Maximum 99999 hrs 59 minutes (approximately 11yrs 4months)
Number of starts	1,000,000 (1 million)

The number of logged Engine Hours and Number of Starts can be set/reset using the DSE Configuration Suite PC software. Depending upon module configuration, this may have been PIN number locked by your generator supplier

3.11 DIMENSIONS AND MOUNTING

3.11.1 DIMENSIONS

240.0mm x 181.1mm x 41.7mm (9.4" x 7.1" x 1.6")

3.11.2 PANEL CUTOUT

220mm x 160mm (8.7" x 6.3")

3.11.3 WEIGHT

0.7kg (1.4lb)

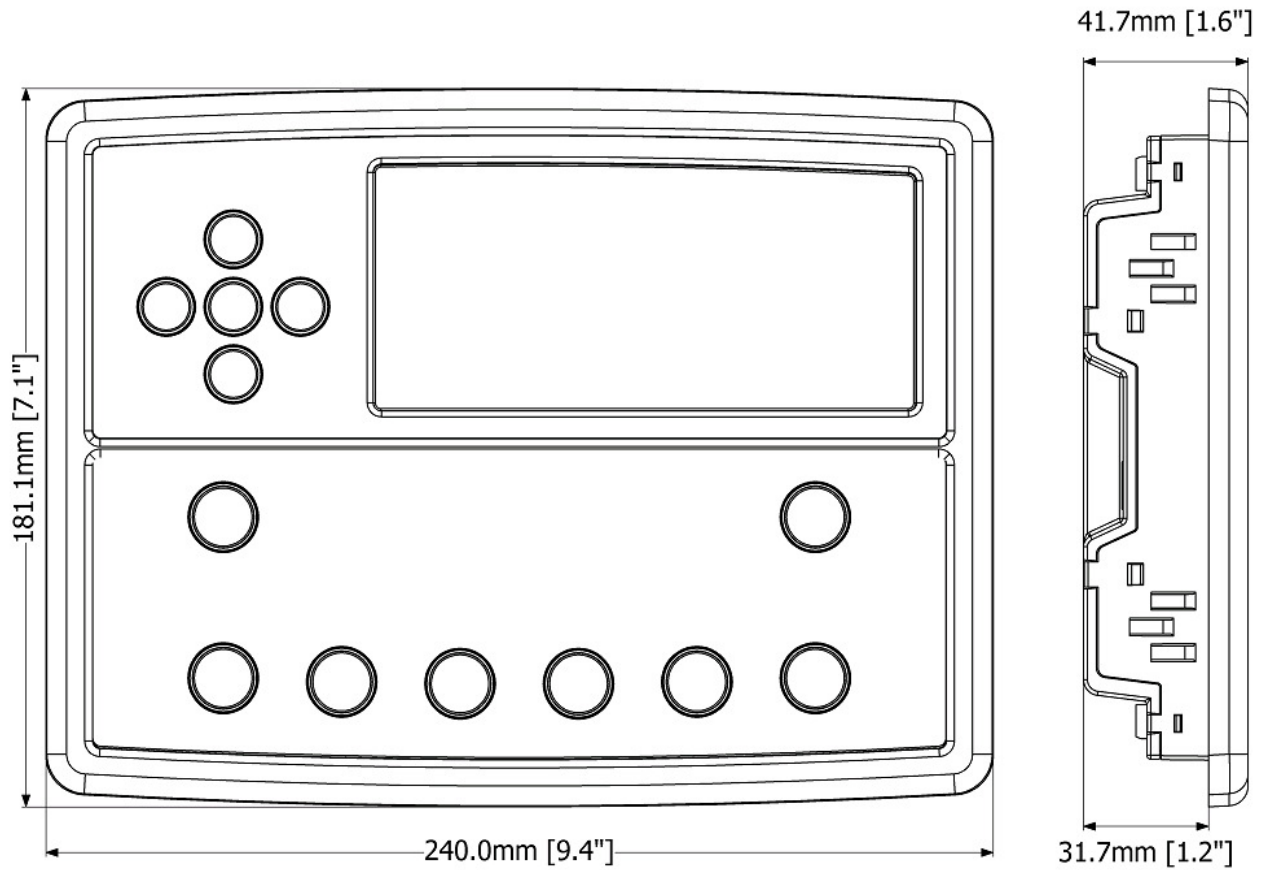

3.11.4 FIXING CLIPS

Supplied fixing clips hold the module into the panel fascia.

Withdraw the fixing clip screw (turn anticlockwise) until only the pointed end is protruding from the clip.

- Insert the three 'prongs' of the fixing clip into the slots in the side of the 8600 series module case.
- Pull the fixing clip backwards (towards the back of the module) ensuring all three prongs of the clip are inside their allotted slots.
- Turn the fixing clip screws clockwise until they make contact with the panel fascia.
- Turn the screws a little more to secure the module into the panel fascia. Take care not to over tighten the fixing clip screws.

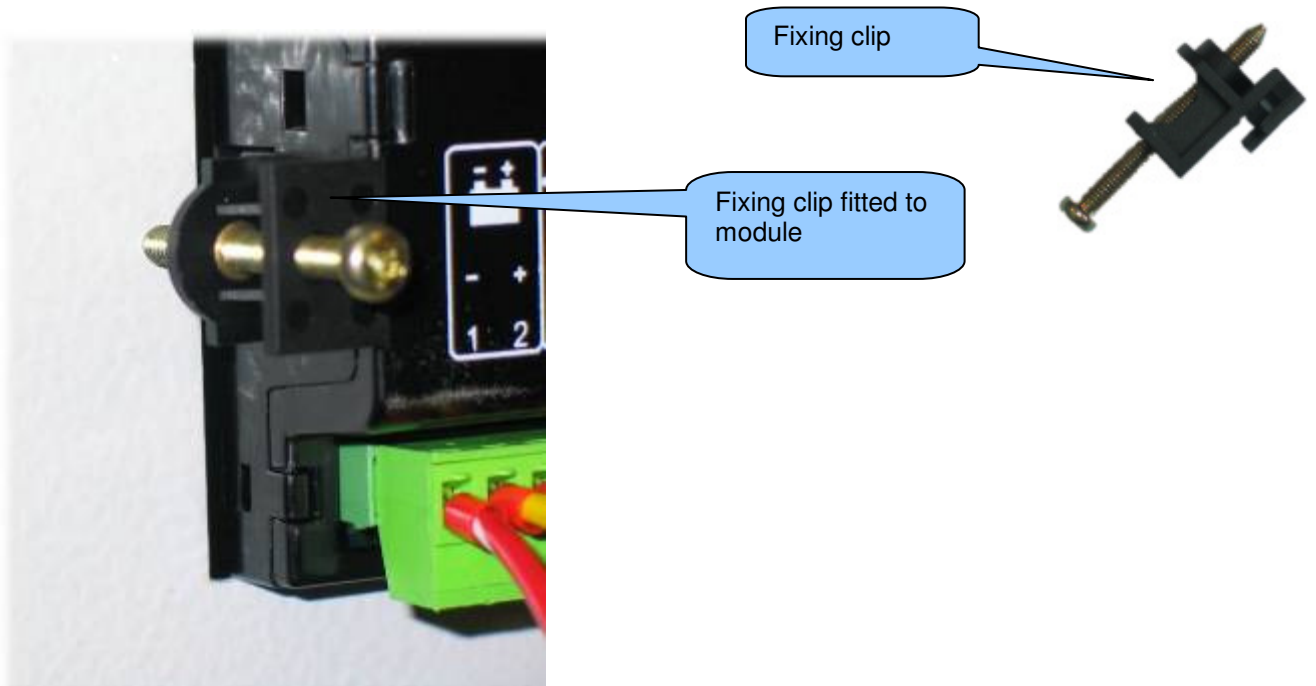

NOTE: In conditions of excessive vibration, mount the module on suitable anti-vibration mountings.

3.11.5 CABLE TIE FIXING POINTS

Integral cable tie fixing points are included on the rear of the module's case to aid wiring. This additionally provides strain relief to the cable loom by removing the weight of the loom from the screw connectors, thus reducing the chance of future connection failures. Care should be taken not to over tighten the cable tie (for instance with cable tie tools) to prevent the risk of damage to the module case.



Cable tie fixing point

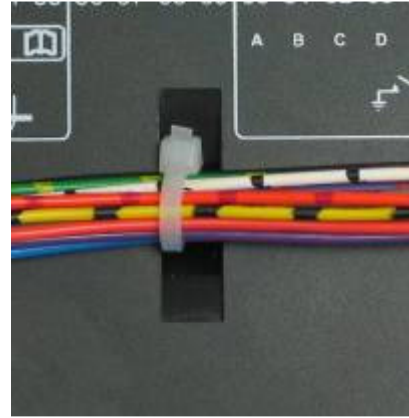

With cable and tie in place

3.11.6 SILICON SEALING GASKET

The supplied silicon gasket provides improved sealing between the 8600 series module and the panel fascia.

The gasket is fitted to the module before installation into the panel fascia.

Take care to ensure the gasket is correctly fitted to the module to maintain the integrity of the seal.

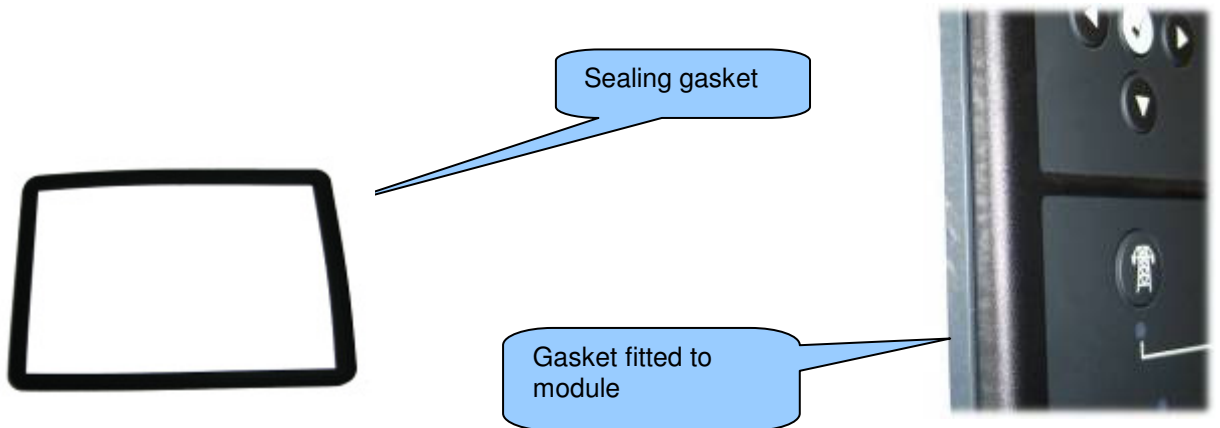

3.12 APPLICABLE STANDARDS

BS 4884-1	This document conforms to BS4884-1 1992 Specification for presentation of essential information.
BS 4884-2	This document conforms to BS4884-2 1993 Guide to content
BS 4884-3	This document conforms to BS4884-3 1993 Guide to presentation
BS EN 60068-2-1 (Minimum temperature)	-30°C (-22°F)
BS EN 60068-2-2 (Maximum temperature)	+70°C (158°F)
BS EN 60950	Safety of information technology equipment, including electrical business equipment
BS EN 61000-6-2	EMC Generic Immunity Standard (Industrial)
BS EN 61000-6-4	EMC Generic Emission Standard (Industrial)
BS EN 60529 (Degrees of protection provided by enclosures) (see overleaf)	IP65 (front of module when installed into the control panel with the supplied sealing gasket) IP42 (front of module when installed into the control panel WITHOUT being sealed to the panel)
UL508 NEMA rating (Approximate) (see overleaf)	12 (Front of module when installed into the control panel with the supplied sealing gasket). 2 (Front of module when installed into the control panel WITHOUT being sealed to the panel)
IEEE C37.2 (Standard Electrical Power System Device Function Numbers and Contact Designations)	<p>Under the scope of IEEE 37.2, <i>function numbers can also be used to represent functions in microprocessor devices and software programs.</i> The 8610 series controller is device number 11L-8610 (Multifunction device protecting Line (generator) – 8610 series module).</p> <p>As the module is configurable by the generator OEM, the functions covered by the module will vary. Under the module's factory configuration, the device numbers included within the module are :</p> <ul style="list-style-type: none"> 2 – Time delay starting or closing relay 6 – Starting circuit breaker 27AC – AC undervoltage relay 27DC – DC undervoltage relay 30 – annunciator relay 42 – Running circuit breaker 50 – instantaneous overcurrent relay 51 – ac time overcurrent relay 52 – ac circuit breaker 53DC – exciter or dc generator relay 54 – turning gear engaging device 59AC – AC overvoltage relay 59DC – DC overvoltage relay 62 – time delay stopping or opening relay 63 – pressure switch 74– alarm relay 81 – frequency relay 86 – lockout relay

In line with our policy of continual development, Deep Sea Electronics, reserve the right to change specification without notice.

3.12.1 ENCLOSURE CLASSIFICATIONS

IP CLASSIFICATIONS

8600 series specification under BS EN 60529 Degrees of protection provided by enclosures

IP65 (Front of module when module is installed into the control panel with the optional sealing gasket).

IP42 (front of module when module is installed into the control panel WITHOUT being sealed to the panel)

First Digit	Second Digit
Protection against contact and ingress of solid objects 0 No protection	Protection against ingress of water 0 No protection
1 Protected against ingress solid objects with a diameter of more than 50 mm. No protection against deliberate access, e.g. with a hand, but large surfaces of the body are prevented from approach.	1 Protection against dripping water falling vertically. No harmful effect must be produced (vertically falling drops).
2 Protected against penetration by solid objects with a diameter of more than 12 mm. Fingers or similar objects prevented from approach.	2 Protection against dripping water falling vertically. There must be no harmful effect when the equipment (enclosure) is tilted at an angle up to 15° from its normal position (drops falling at an angle).
3 Protected against ingress of solid objects with a diameter of more than 2.5 mm. Tools, wires etc. with a thickness of more than 2.5 mm are prevented from approach.	3 Protection against water falling at any angle up to 60° from the vertical. There must be no harmful effect (spray water).
4 Protected against ingress of solid objects with a diameter of more than 1 mm. Tools, wires etc. with a thickness of more than 1 mm are prevented from approach.	4 Protection against water splashed against the equipment (enclosure) from any direction. There must be no harmful effect (splashing water).
5 Protected against harmful dust deposits. Ingress of dust is not totally prevented but the dust must not enter in sufficient quantity to interfere with satisfactory operation of the equipment. Complete protection against contact.	5 Protection against water projected from a nozzle against the equipment (enclosure) from any direction. There must be no harmful effect (water jet).
6 Protection against ingress of dust (dust tight). Complete protection against contact.	6 Protection against heavy seas or powerful water jets. Water must not enter the equipment (enclosure) in harmful quantities (splashing over).

3.12.2 NEMA CLASSIFICATIONS

8600 series NEMA Rating (Approximate)

12 (Front of module when module is installed into the control panel with the optional sealing gasket).

2 (front of module when module is installed into the control panel WITHOUT being sealed to the panel)

 **NOTE: - There is no direct equivalence between IP / NEMA ratings. IP figures shown are approximate only.**

1 IP30	Provides a degree of protection against contact with the enclosure equipment and against a limited amount of falling dirt.
2 IP31	Provides a degree of protection against limited amounts of falling water and dirt.
3 IP64	Provides a degree of protection against windblown dust, rain and sleet; undamaged by the formation of ice on the enclosure.
3R IP32	Provides a degree of protection against rain and sleet;; undamaged by the formation of ice on the enclosure.
4 (X) IP66	Provides a degree of protection against splashing water, windblown dust and rain, hose directed water; undamaged by the formation of ice on the enclosure. (Resist corrosion).
12/12K IP65	Provides a degree of protection against dust, falling dirt and dripping non corrosive liquids.
13 IP65	Provides a degree of protection against dust and spraying of water, oil and non corrosive coolants.

4 INSTALLATION

The DSE8600 Series module is designed to be mounted on the panel fascia. For dimension and mounting details, see the section entitled *Specification, Dimension and mounting* elsewhere in this document.

4.1 TERMINAL DESCRIPTION

4.1.1 DC SUPPLY, FUEL AND START OUTPUTS

Icon	PIN No	DESCRIPTION	CABLE SIZE	NOTES
	1	DC Plant Supply Input (Negative)	2.5mm ² AWG 13	
	2	DC Plant Supply Input (Positive)	2.5 mm ² AWG 13	(Recommended Maximum Fuse 15A anti-surge) Supplies the module (2A anti-surge requirement) and Output relays E - K
	3	Emergency Stop Input	2.5mm ² AWG 13	Plant Supply Positive. In addition, supplies outputs 1 & 2. (Recommended Maximum Fuse 20A)
	4	Output relay A (FUEL)	2.5mm ² AWG 13	Plant Supply Positive from terminal 3. 15 Amp rated. Fixed as FUEL relay if electronic engine is not configured.
	5	Output relay B (START)	2.5mm ² AWG 13	Plant Supply Positive from terminal 3. 15 Amp rated. Fixed as START relay if electronic engine is not configured.
	6	Charge fail / excite	2.5mm ² AWG 13	Do not connect to ground (battery negative). If charge alternator is not fitted, leave this terminal disconnected.
	7	Functional Earth	2.5mm ² AWG 13	Connect to a good clean earth point.
	8	Output relay E	1.0mm ² AWG 18	Plant Supply Positive from terminal 2. 3 Amp rated.
	9	Output relay F	1.0mm ² AWG 18	Plant Supply Positive from terminal 2. 3 Amp rated.
	10	Output relay G	1.0mm ² AWG 18	Plant Supply Positive. from terminal 2. 3 Amp rated.
	11	Output relay H	1.0mm ² AWG 18	Plant Supply Positive from terminal 2. 3 Amp rated.
	12	Output relay I	1.0mm ² AWG 18	Plant Supply Positive from terminal 2. 3 Amp rated.
	13	Output relay J	1.0mm ² AWG 18	Plant Supply Positive from terminal 2. 3 Amp rated.

NOTE: Terminal 14 is not fitted to the DSE8600 series controller.

NOTE: When the module is configured for operation with an electronic engine, FUEL and START output requirements may be different. Refer to *Electronic Engines and DSE Wiring* for further information. DSE Part No. 057-004.

4.1.2 ANALOGUE SENSORS







	PIN No	DESCRIPTION	CABLE SIZE	NOTES
	15	Sensor Common Return	0.5mm ² AWG 20	Return feed for sensors
	16	Oil Pressure Input	0.5mm ² AWG 20	Connect to Oil pressure sensor
	17	Coolant Temperature Input	0.5mm ² AWG 20	Connect to Coolant Temperature sensor
	18	Fuel Level input	0.5mm ² AWG 20	Connect to Fuel Level sensor
	19	Flexible sensor	0.5mm ² AWG 20	Connect to additional sensor (user configurable)

 **NOTE: Terminals 20 and 21 are not fitted to the 8600 series controller.**

 **NOTE: It is VERY important that terminal 15 (sensor common) is soundly connected to an earth point on the ENGINE BLOCK, not within the control panel, and must be a sound electrical connection to the sensor bodies. This connection MUST NOT be used to provide an earth connection for other terminals or devices. The simplest way to achieve this is to run a SEPARATE earth connection from the system earth star point, to terminal 15 directly, and not use this earth for other connections.**

 **NOTE: If you use PTFE insulating tape on the sensor thread when using earth return sensors, ensure you do not insulate the entire thread, as this will prevent the sensor body from being earthed via the engine block.**

4.1.3 MAGNETIC PICKUP, CAN AND EXPANSION

	PIN No	DESCRIPTION	CABLE SIZE	NOTES
	22	Magnetic pickup Positive	0.5mm ² AWG 20	Connect to Magnetic Pickup device
	23	Magnetic pickup Negative	0.5mm ² AWG 20	Connect to Magnetic Pickup device
	24	Magnetic pickup screen	Shield	Connect to ground at one end only
	25	CAN port H	0.5mm ² AWG 20	Use only 120Ω CAN approved cable
	26	CAN port L	0.5mm ² AWG 20	Use only 120Ω CAN approved cable
	27	CAN port Common	0.5mm ² AWG 20	Use only 120Ω CAN approved cable
	28	DSENet expansion +	0.5mm ² AWG 20	Use only 120Ω RS485 approved cable
	29	DSENet expansion -	0.5mm ² AWG 20	Use only 120Ω RS485 approved cable
	30	DSENet expansion SCR	0.5mm ² AWG 20	Use only 120Ω RS485 approved cable
	31	Multiset Comms (MSC) Link H	0.5mm ² AWG 20	Use only 120Ω RS485 approved cable
	32	Multiset Comms (MSC) Link L	0.5mm ² AWG 20	Use only 120Ω RS485 approved cable
	33	Multiset Comms (MSC) Link SCR	0.5mm ² AWG 20	Use only 120Ω RS485 approved cable
	34	Analogue Governor Output B	0.5mm ² AWG 20	
	35	Analogue Governor Output A	0.5mm ² AWG 20	
	37	Analogue AVR Output B	0.5mm ² AWG 20	
	38	Analogue AVR Output A	0.5mm ² AWG 20	

 **NOTE: Terminal 36 is not fitted to the 8610 controller**



 **NOTE: Screened cable must be used for connecting the Magnetic Pickup, ensuring that the screen is earthed at one end ONLY.**

 **NOTE: Screened 120Ω impedance cable specified for use with CAN must be used for the CAN link and the Multiset comms (MSC) link.
DSE stock and supply Belden cable 9841 which is a high quality 120Ω impedance cable suitable for CAN use (DSE part number 016-030)**

 **NOTE: When the module is configured for CAN operation, terminals 22, 23 & 24 should be left unconnected. Engine speed is transmitted to the 8600 series controller on the CAN link. Refer to *Electronic Engines and DSE Wiring* for further information. Part No. 057-004.**

 **NOTE: The Multiset comms (MSC) link Version 5.1+ includes a protocol change to enable communication with other DSE 55xx and 75xx modules. If one 86xx module is at version 5.0 all 86xx series need to be at 5.0+ to avoid incompatibility.**

4.1.4 LOAD SWITCHING AND GENERATOR VOLTAGE SENSING

	PIN No	DESCRIPTION	CABLE SIZE	NOTES
	39	Output relay C	1.0mm AWG 18	Normally configured to control load switching device (Recommend 10A fuse)
	40	Output relay C	1.0mm AWG 18	Normally configured to control load switching device
	41	Output relay D	1.0mm AWG 18	Normally configured to control load switching device (Recommend 10A fuse)
	42	Output relay D	1.0mm AWG 18	Normally configured to control load switching device
V1	43	Generator L1 (U) voltage monitoring	1.0mm ² AWG 18	Connect to generator L1 (U) output (AC) (Recommend 2A fuse)
	44	Generator L2 (V) voltage monitoring input	1.0mm ² AWG 18	Connect to generator L2 (V) output (AC) (Recommend 2A fuse)
	45	Generator L3 (W) voltage monitoring input	1.0mm ² AWG 18	Connect to generator L3 (W) output (AC) (Recommend 2A fuse)
	46	Generator Neutral (N) input	1.0mm ² AWG 18	Connect to generator Neutral terminal (AC)

NOTE: The above table describes connections to a three phase, four wire alternator. For alternative wiring topologies, please see the **ALTERNATIVE AC TOPOLOGIES** section of this manual.

4.1.5 BUS SENSING

These connections are to the common bus supply of the generator system.

	PIN No	DESCRIPTION	CABLE SIZE	NOTES
V2	47	Bus L1 (R) voltage monitoring	1.0mm AWG 18	Connect to Bus L1 (R) incoming supply (AC) (Recommend 2A fuse)
	48	Bus L2 (S) voltage monitoring	1.0mm AWG 18	Connect to Bus L1 (S) incoming supply (AC) (Recommend 2A fuse)
	49	Bus L3 (T) voltage monitoring	1.0mm AWG 18	Connect to Bus L1 (T) incoming supply (AC) (Recommend 2A fuse)
	50	Bus Neutral (N) input	1.0mm AWG 18	Connect to Bus N incoming supply (AC)

4.1.6 GENERATOR CURRENT TRANSFORMERS

WARNING! Do not disconnect this plug when the CTs are carrying current. Disconnection will open circuit the secondary of the C.T.'s and dangerous voltages may then develop. Always ensure the CTs are not carrying current and the CTs are short circuit connected before making or breaking connections to the module.

NOTE: The 8600 series module has a burden of 0.5VA on the CT. Ensure the CT is rated for the burden of the 8600 series controller, the cable length being used and any other equipment sharing the CT. If in doubt, consult your CT supplier.

NOTE: Take care to ensure correct polarity of the CT primary as shown below. If in doubt, check with the CT supplier.

CT LABELLING

p1, κ or K is the primary of the CT that 'points' towards the GENERATOR

p2, ℓ or L is the primary of the CT that 'points' towards the LOAD

s1 is the secondary of the CT that connects to the DSE Module's input for the CT measuring (I1,I2,I3)

s2 is the secondary of the CT that should be commoned with the s2 connections of all the other CTs and connected to the CT common terminal of the DSE8600 series modules.

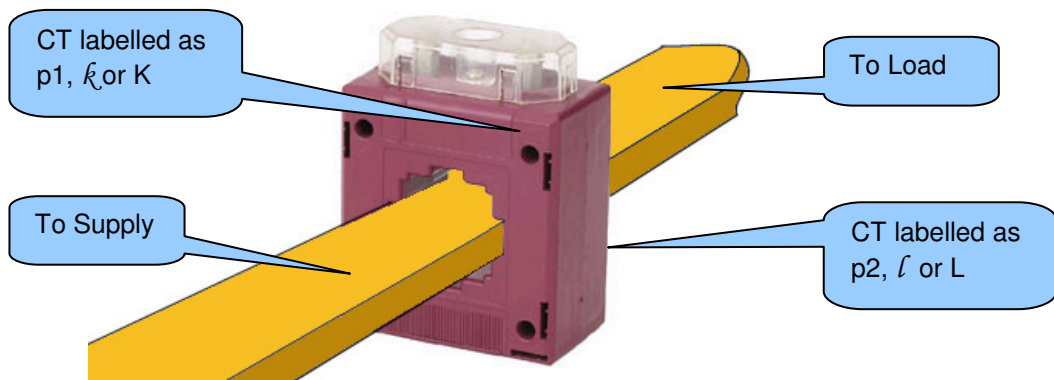

Connection of CT s1 terminal

	PIN No	DESCRIPTION	CABLE SIZE	NOTES
	51	CT Secondary for Gen L1	2.5mm ² AWG 13	Connect to s1 secondary of L1 monitoring CT
	52	CT Secondary for Gen L2	2.5mm ² AWG 13	Connect to s1 secondary of L2 monitoring CT
	53	CT Secondary for Gen L3	2.5mm ² AWG 13	Connect to s1 secondary of L3 monitoring CT

Connection to terminals 54 & 55

The function of terminals 54 and 55 CHANGES depending upon what kind of earth fault protection (if any) is being used:

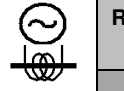
	Topology	Pin No	Description	CABLE SIZE
	No earth fault measuring	54	DO NOT CONNECT	
		55	Connect to s2 of the CTs connected to L1,L2,L3,N	2.5mm ² AWG 13
	Restricted earth fault measuring	54	Connect to s2 of the CTs connected to L1,L2,L3,N	2.5mm ² AWG 13
		55	Connect to s1 of the CT on the neutral conductor	2.5mm ² AWG 13
	Un-restricted earth fault measuring (Earth fault CT is fitted in the neutral to earth link)	54	Connect to s1 of the CT on the neutral to earth conductor.	2.5mm ² AWG 13
		55	Connect to s2 of the CT on the neutral to earth link. Also connect to the s2 of CTs connected to L1, L2, L3.	2.5mm ² AWG 13

▲NOTE: Take care to ensure correct polarity of the CT primary as shown overleaf. If in doubt, check with the CT supplier.



▲NOTE: Terminals 56 to 59 are not fitted to the 8610 series controller.

4.1.7 CONFIGURABLE DIGITAL INPUTS

PIN No	DESCRIPTION	CABLE SIZE	NOTES
60	Configurable digital input A	0.5mm ² AWG 20	Switch to negative
61	Configurable digital input B	0.5mm ² AWG 20	Switch to negative
62	Configurable digital input C	0.5mm ² AWG 20	Switch to negative
63	Configurable digital input D	0.5mm ² AWG 20	Switch to negative
64	Configurable digital input E	0.5mm ² AWG 20	Switch to negative
65	Configurable digital input F	0.5mm ² AWG 20	Switch to negative
66	Configurable digital input G	0.5mm ² AWG 20	Switch to negative
67	Configurable digital input H	0.5mm ² AWG 20	Switch to negative
68	Configurable digital input I	0.5mm ² AWG 20	Switch to negative
69	Configurable digital input J	0.5mm ² AWG 20	Switch to negative
70	Configurable digital input K	0.5mm ² AWG 20	Switch to negative

4.1.8 PC CONFIGURATION INTERFACE CONNECTOR

This configuration cable is the same as normally used between a PC and a USB printer!

DESCRIPTION	CABLE SIZE	NOTES
 <p>Socket for connection to PC with 86xx series PC software.</p>	0.5mm ² AWG 20	<p>This is a standard USB type A to type B connector.</p> 

NOTE: The USB connection cable between the PC and the 8600 series module must not be extended beyond 5m (yards). For distances over 5m, it is possible to use a third party USB extender. Typically, they extend USB up to 50m (yards). The supply and support of this type of equipment is outside the scope of Deep Sea Electronics PLC.

CAUTION! Care must be taken not to overload the PCs USB system by connecting more than the recommended number of USB devices to the PC. For further information, consult your PC supplier.

CAUTION! This socket must not be used for any other purpose.

4.1.9 RS485 CONNECTOR

PIN No	NOTES
A	Two core screened twisted pair cable. 120Ω impedance suitable for RS485 use.
B	Recommended cable type - Belden 9841
SCR	Max distance 1200m (1.2km) when using Belden 9841 or direct equivalent.

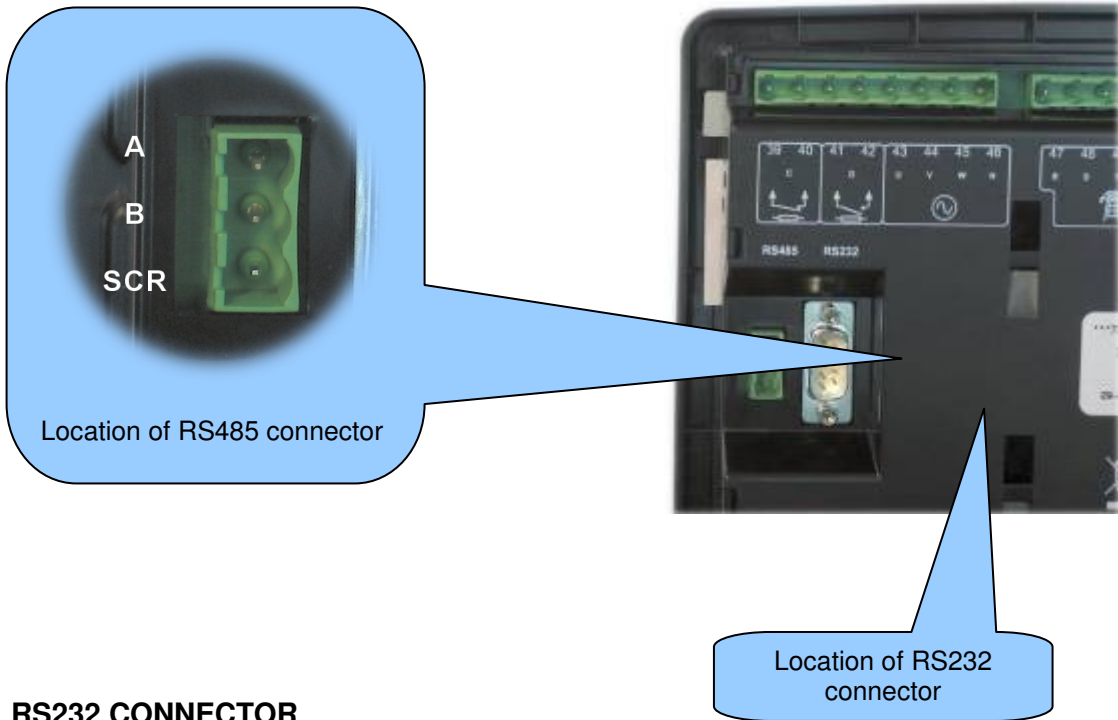

4.1.10 RS232 CONNECTOR

PIN No	NOTES
1	Received Line Signal Detector (Data Carrier Detect)
2	Received Data
3	Transmit Data
4	Data Terminal Ready
5	Signal Ground
6	Data Set Ready
7	Request To Send
8	Clear To Send
9	Ring Indicator

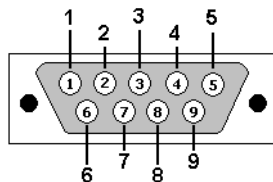

View looking into the male connector on the 8600 series module

4.2 TYPICAL WIRING DIAGRAMS

As every system has different requirements, these diagrams show only a TYPICAL system and do not intend to show a complete system.

Genset manufacturers and panel builders may use these diagrams as a starting point; however, you are referred to the completed system diagram provided by your system manufacturer for complete wiring detail.

Further wiring suggestions are available in the following DSE publications, available at www.deepseapl.com to website members.

DSE PART	DESCRIPTION
056-022	Breaker Control (Training guide)
057-004	Electronic Engines and DSE Wiring

4.2.1 3 PHASE, 4 WIRE WITH RESTRICTED EARTH FAULT PROTECTION

NOTE: Earthing the neutral conductor 'before' the neutral CT allows the module to read earth faults 'after' the CT only (Restricted to load / downstream of the CT)
 Earthing the neutral conductor 'after' the neutral CT allows the module to read earth faults 'before' the CT only (Restricted to generator / upstream of the CT)

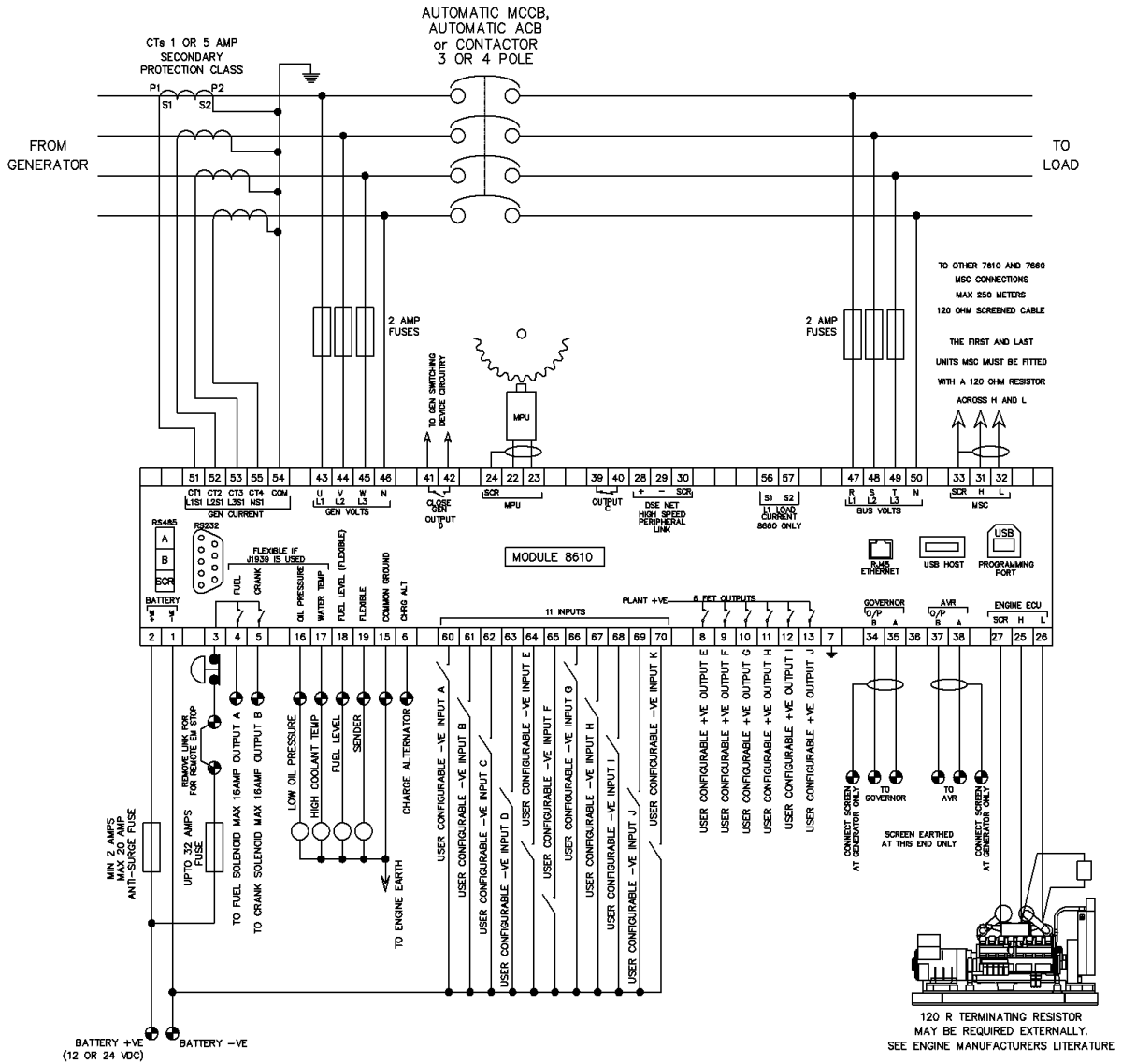

4.2.2 3 PHASE, 4 WIRE WITHOUT EARTH FAULT PROTECTION

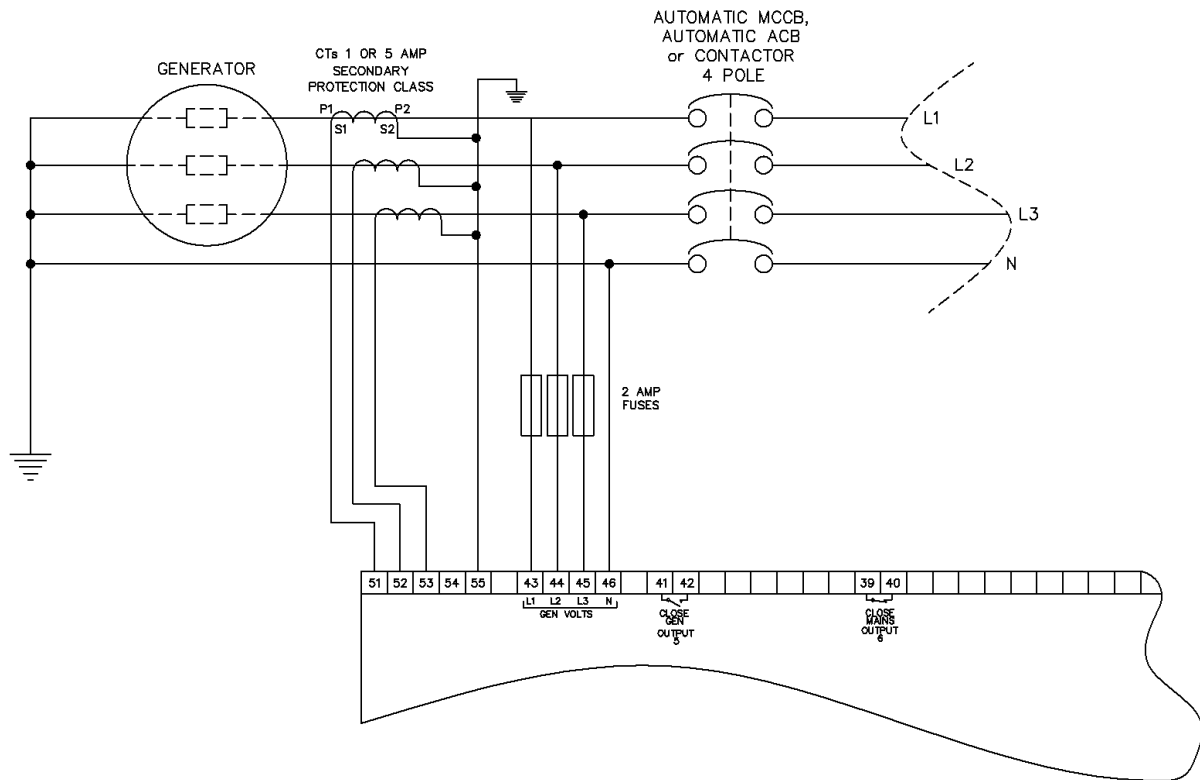

4.2.3 3 PHASE 4 WIRE WITH UNRESTRICTED EARTH FAULT PROTECTION

NOTE:- Unrestricted Earth Fault Protection detects earth faults in the load and in the generator. Be sure to measure the natural earth fault of the site before deciding upon an earth fault alarm trip level.

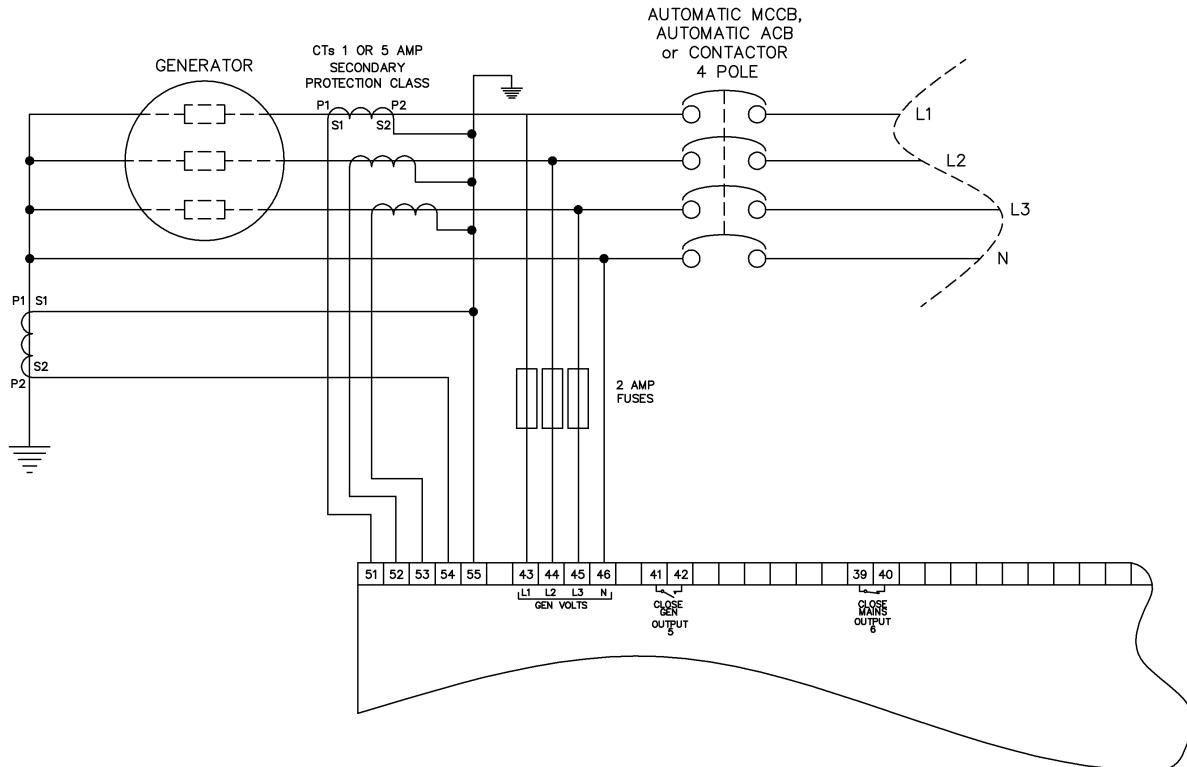

4.2.4 EARTH SYSTEMS

4.2.4.1 NEGATIVE EARTH

The typical wiring diagrams located within this document show connections for a negative earth system (the battery negative connects to Earth)

4.2.4.2 POSITIVE EARTH

When using a DSE module with a Positive Earth System (the battery positive connects to Earth), the following points must be followed:

- Follow the typical wiring diagram as normal for all sections EXCEPT the earth points
- All points shown as Earth on the typical wiring diagram should connect to BATTERY NEGATIVE (not earth).

4.2.4.3 FLOATING EARTH

Where neither the battery positive nor battery negative terminals are connected to earth the following points must be followed

- Follow the typical wiring diagram as normal for all sections EXCEPT the earth points
- All points shown as Earth on the typical wiring diagram should connect to BATTERY NEGATIVE (not earth).

4.3 ALTERNATIVE TOPOLOGIES

The DSE8610 controller is factory configured to connect to a 3 phase, 4 wire Star connected alternator. This section details connections for alternative AC topologies. Ensure to configure the DSE8610 controller to suit the required topology.

NOTE: Further details of module configuration are contained within the DSE8610 Series configuration software manual (DSE part number 057-119)

4.3.1 SINGLE PHASE WITH RESTRICTED EARTH FAULT

NOTE: Earthing the neutral conductor 'before' the neutral CT allows the module to read earth faults 'after' the CT only (Restricted to load / downstream of the CT)
 Earthing the neutral conductor 'after' the neutral CT allows the module to read earth faults 'before' the CT only (Restricted to generator / upstream of the CT)

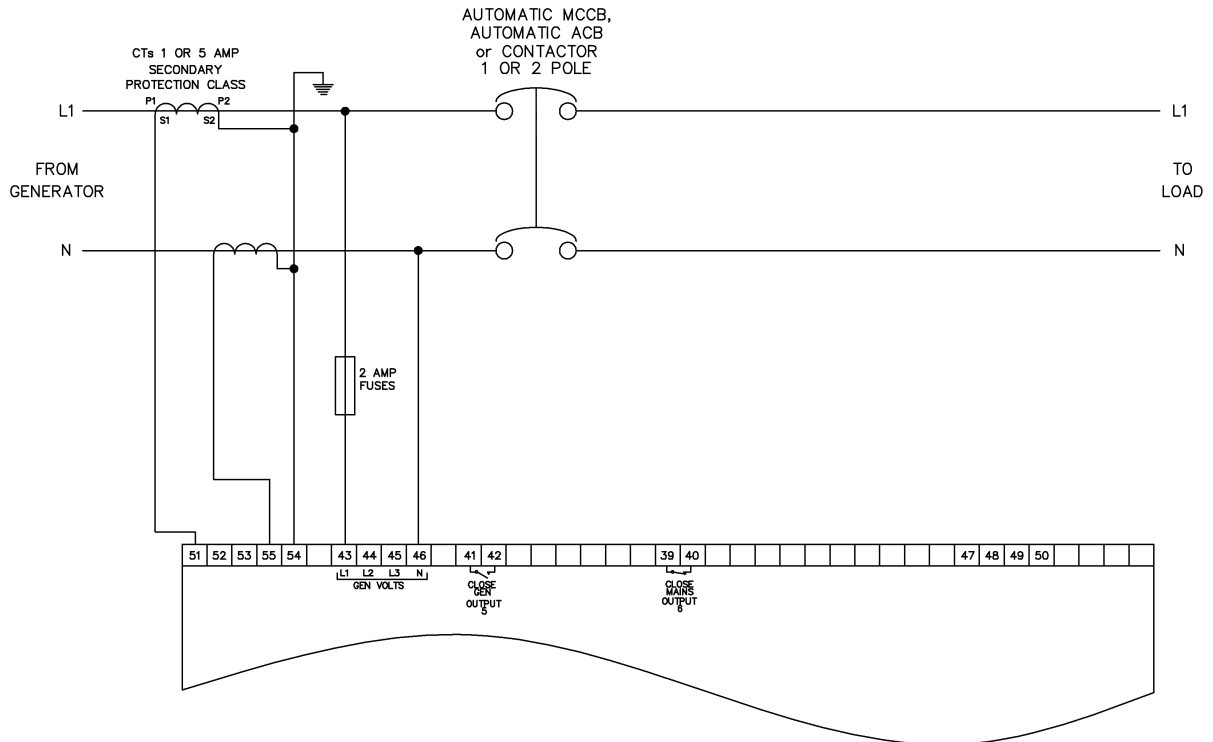

4.3.2 SINGLE PHASE WITHOUT EARTH FAULT

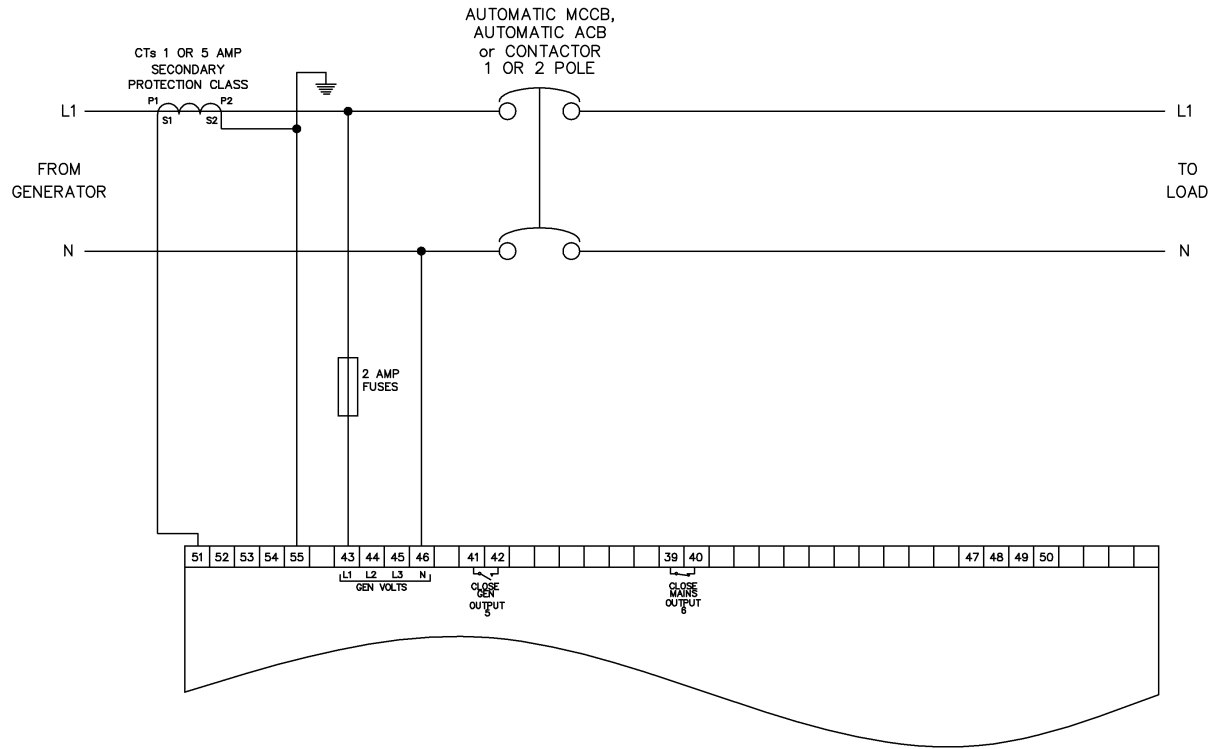

4.3.3 2 PHASE (L1 & L2) 3 WIRE WITH RESTRICTED EARTH FAULT

NOTE: Earthing the neutral conductor 'before' the neutral CT allows the module to read earth faults 'after' the CT only (Restricted to load / downstream of the CT)
 Earthing the neutral conductor 'after' the neutral CT allows the module to read earth faults 'before' the CT only (Restricted to generator / upstream of the CT)

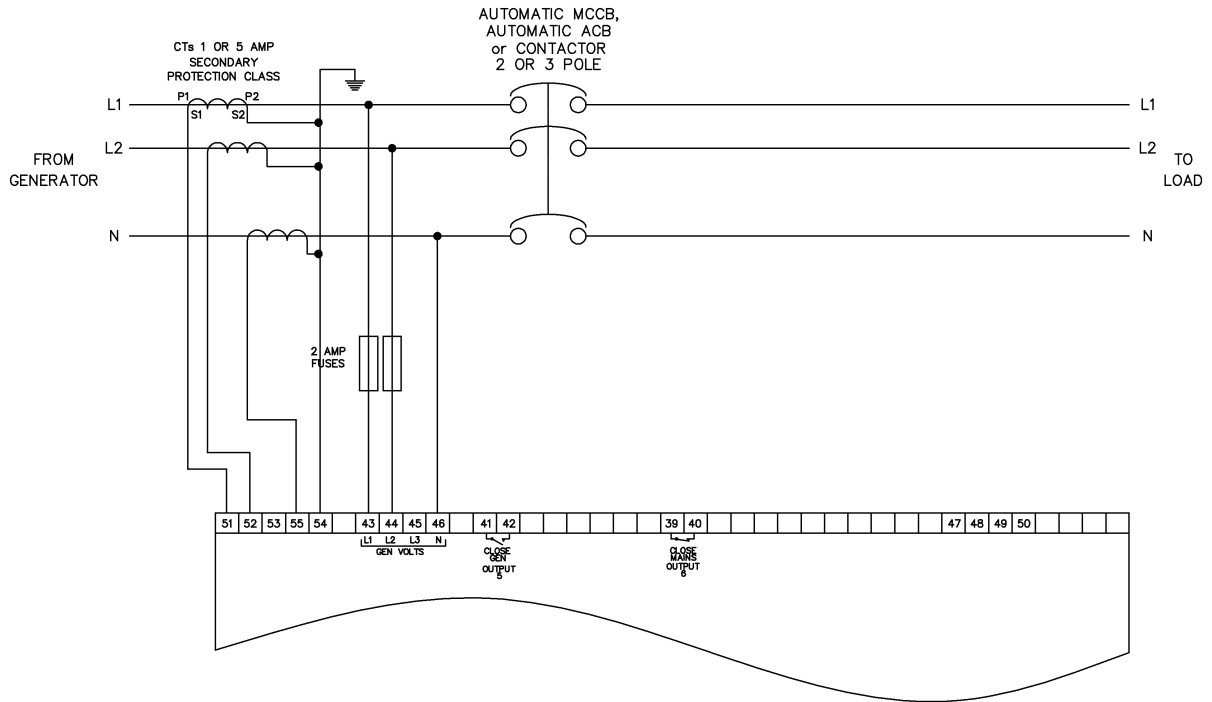

4.3.4 2 PHASE (L1 & L2) 3 WIRE WITHOUT EARTH FAULT

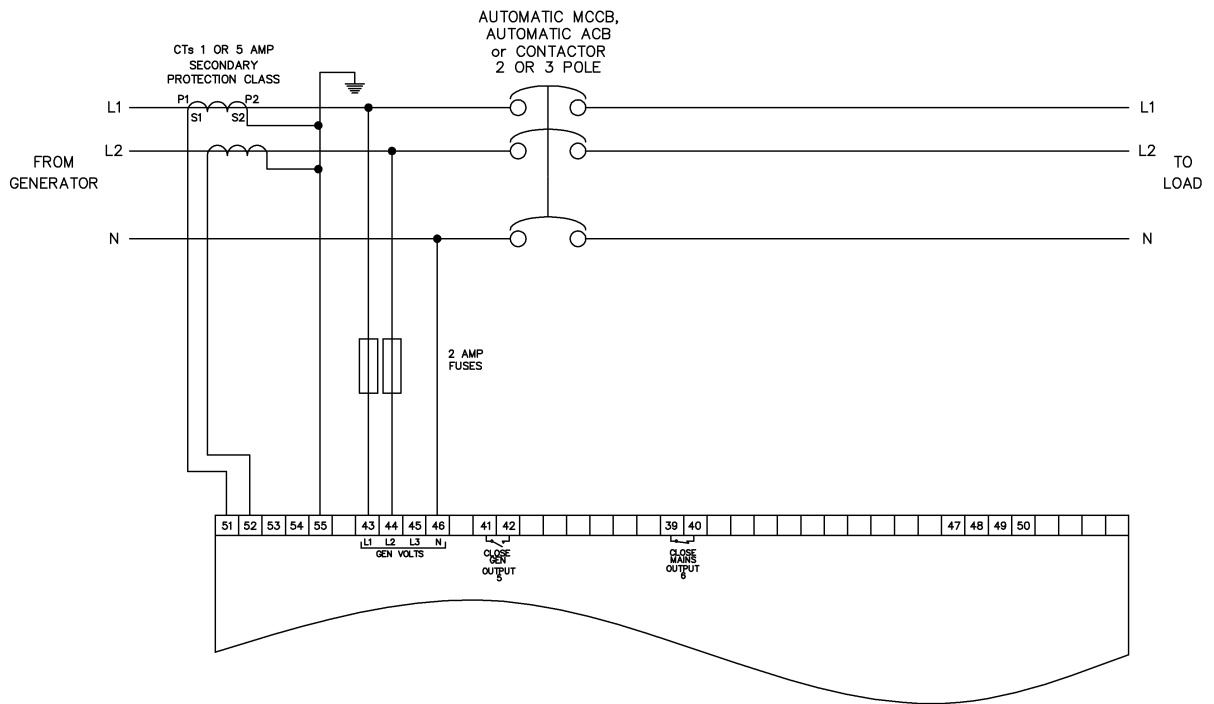

4.3.5 2 PHASE (L1 & L3) 3 WIRE WITH RESTRICTED EARTH FAULT

NOTE: Earthing the neutral conductor 'before' the neutral CT allows the module to read earth faults 'after' the CT only (Restricted to load / downstream of the CT)
 Earthing the neutral conductor 'after' the neutral CT allows the module to read earth faults 'before' the CT only (Restricted to generator / upstream of the CT)

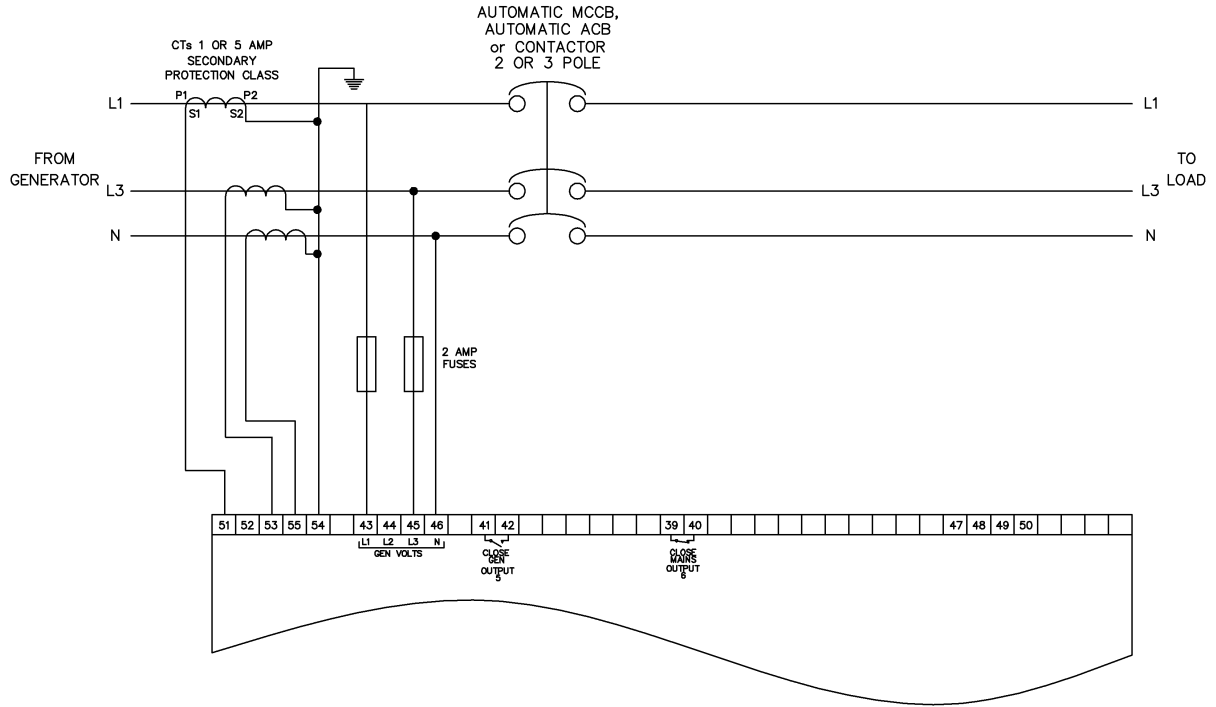

4.3.6 2 PHASE (L1 & L3) 3 WIRE WITHOUT EARTH FAULT MEASURING

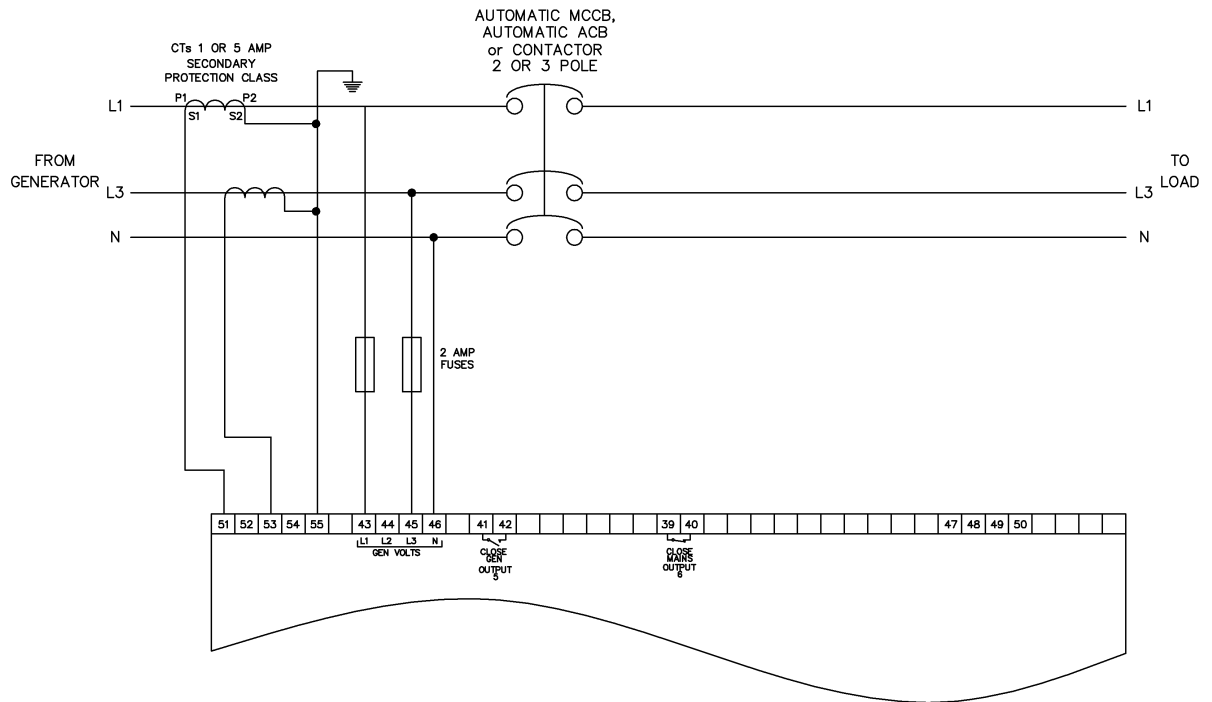

4.4 TYPICAL ARRANGEMENT OF DSENET®

Twenty (20) devices can be connected to the DSENet®, made up of the following devices :

Device	Max number supported
DSE2130 Input Expansion	4
DSE2131 Input Expansion	4
DSE2133 Input Expansion	4
DSE2152 Output Expansion	4
DSE2157 Output Expansion	10
DSE2548 LED Expansion	10

For part numbers of the expansion modules and their documentation, see section entitled *DSENet Expansion Modules* elsewhere in this manual.

NOTE : DSE8600 series does not support the 2510/2520 display modules.

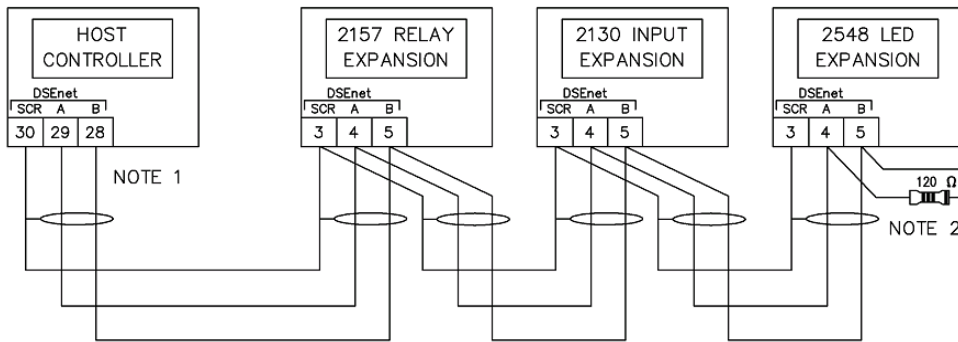

NOTE 1
 AS A TERMINATING RESISTOR IS INTERNALLY FITTED TO THE HOST CONTROLLER, THE HOST CONTROLLER MUST BE THE FIRST UNIT ON THE DSEnet

NOTE 2
 A 120 OHM TERMINATION RESISTOR MUST BE FITTED TO THE LAST UNIT ON THE DSEnet

5 DESCRIPTION OF CONTROLS

The following section details the function and meaning of the various controls on the module.

5.1 DSE8610 AUTOSTART CONTROL MODULE

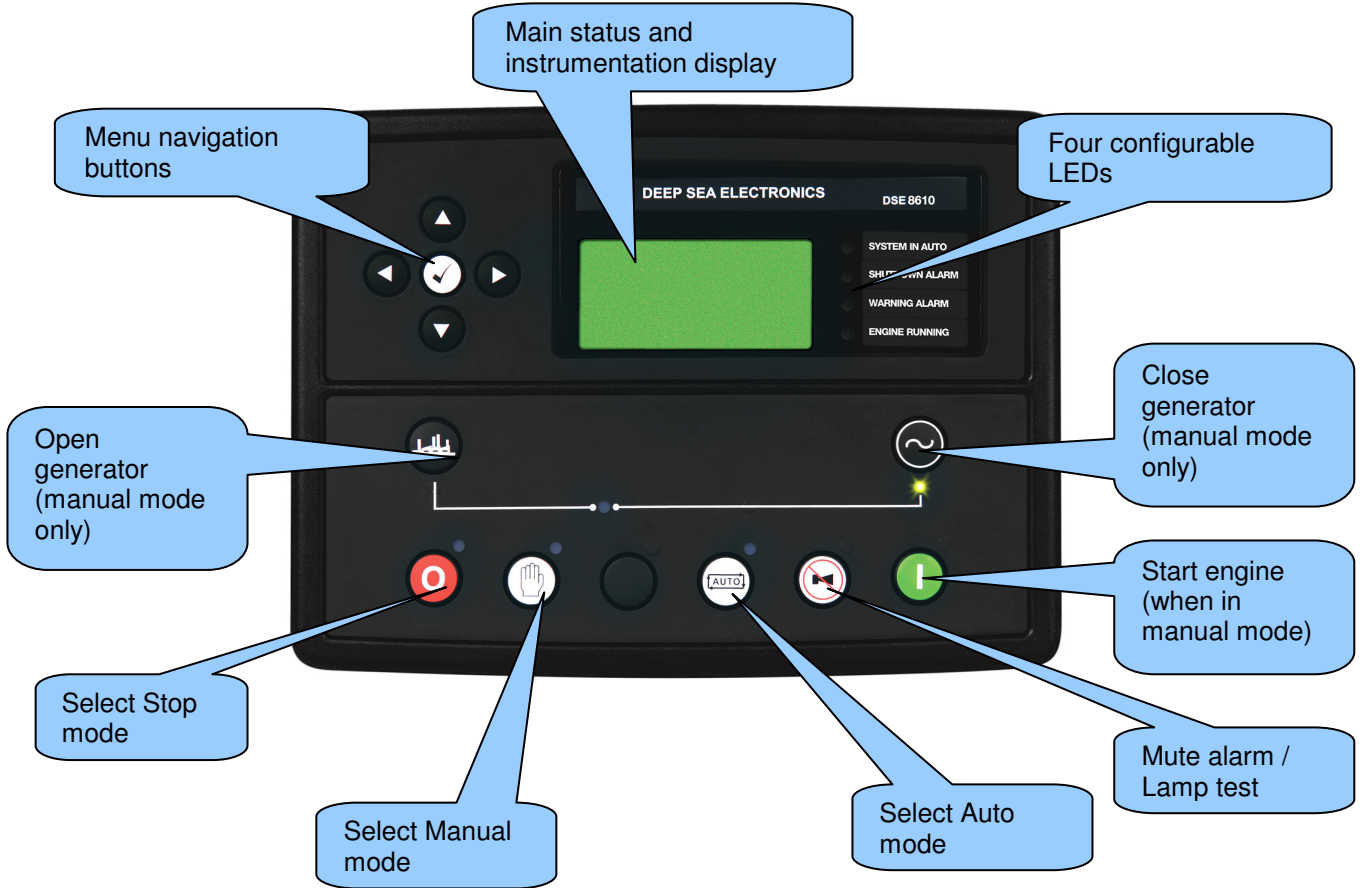

Description Of Controls

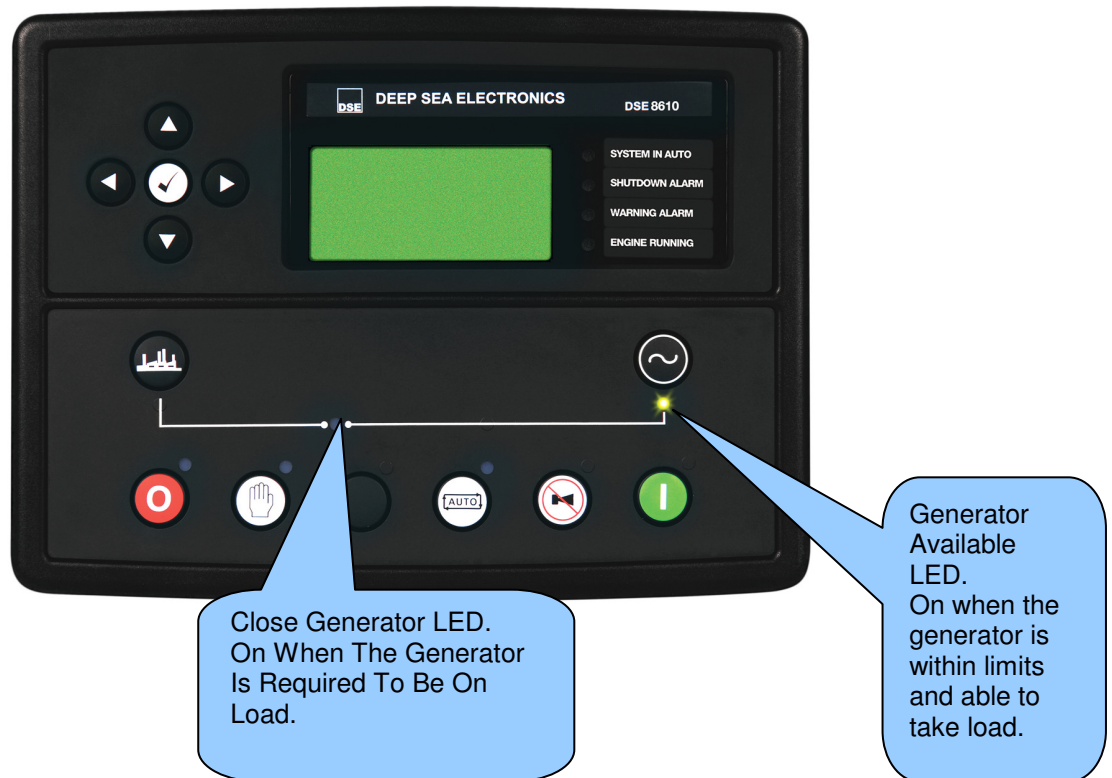

- NOTE:** “Generator on load” LED has two modes of operation depending upon the configuration of the controllers digital inputs.
- 1) Digital input configured for “Generator closed auxiliary” – The LED illuminates when the generator closed auxiliary input is active – The LED shows the state of the auxiliary contact.
 - 2) There is NO input configured for “Generator closed auxiliary” (factory default setting) – The LED illuminates when the DSE8610 gives the loading signal to the generator – The LED shows the state of the DSE8610s loading request.

5.2 QUICKSTART GUIDE

This section provides a quick start guide to the module's operation.

5.2.1 STARTING THE ENGINE



NOTE: For further details, see the section entitled 'OPERATION' elsewhere in this manual.

5.2.2 STOPPING THE ENGINE



NOTE: For further details, see the section entitled 'OPERATION' elsewhere in this manual.

5.3 VIEWING THE INSTRUMENT PAGES

It is possible to scroll to display the different pages of information by repeatedly operating the next /

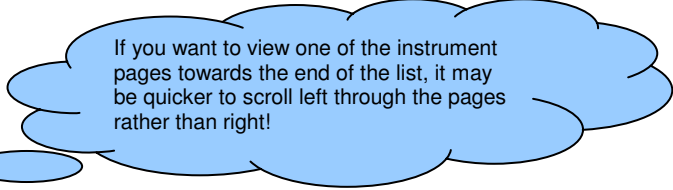
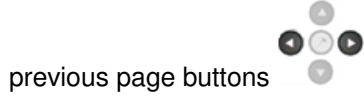

Example



And so on until the last page is reached. A Further press of the scroll right button returns the display to the Status page.

The complete order and contents of each information page are given in the following sections

Once selected the page will remain on the LCD display until the user selects a different page, or after an extended period of inactivity (*LCD Page Timer*), the module will revert to the status display.

If no buttons are pressed upon entering an instrumentation page, the instruments will be displayed automatically subject to the setting of the *LCD Scroll Timer*.

The *LCD Page* and *LCD Scroll* timers are configurable using the DSE Configuration Suite Software or by using the Front Panel Editor.

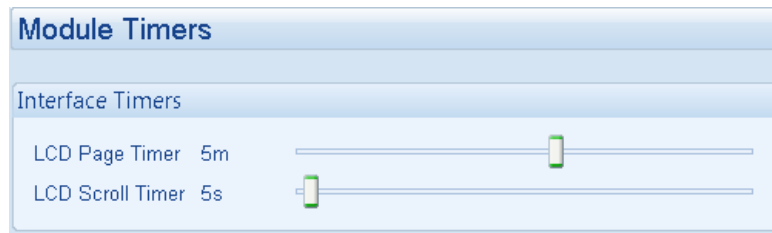

The screenshot shows the factory settings for the timers, taken from the DSE Configuration Suite Software.

Alternatively, to scroll manually through all instruments on the currently selected page, press the scroll



buttons. The 'autoscroll' is disabled.

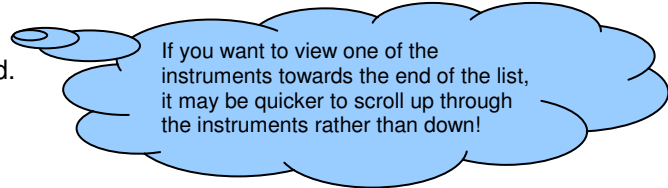

To re-enable 'autoscroll' press the scroll buttons to scroll to the 'title' of the instrumentation page (ie Engine). A short time later (the duration of the *LCD Scroll Timer*), the instrumentation display will begin to autoscroll.

When scrolling manually, the display will automatically return to the Status page if no buttons are pressed for the duration of the configurable *LCD Page Timer*.

If an alarm becomes active while viewing the status page, the display shows the Alarms page to draw the operator's attention to the alarm condition.

5.3.1 STATUS

This is the 'home' page, the page that is displayed when no other page has been selected, and the page that is automatically displayed after a period of inactivity (*LCD Page Timer*) of the module control buttons.

This page is configurable using the DSE Configuration Suite Software.

Status	22:31
Generator at Rest	
Stop Mode	

Factory setting of Status screen showing engine stopped...

Safety on Delay	00:04
L-N	215V 43A
L-L	373v 47.5Hz
	0kw 0.0pf

...and engine running

The contents of this display may vary depending upon configuration by the generator manufacturer / supplier.

The display above is achieved with the factory settings, shown below in the DSE Configuration suite software:

The screenshot shows the 'Configurable Status Screens' interface. It has two main sections: 'Home Page' and 'Displayed Pages'.

- Home Page:** A dropdown menu is set to 'Mode'. A callout bubble points to this dropdown, stating: "'Stop Mode' etc is displayed on the Home Page".
- Displayed Pages:** A table with 10 rows (Page 1 to Page 10) and 2 columns. Page 1 is set to 'Summary screen'. A callout bubble points to this dropdown, stating: "With a summary of the instrumentation shown when the engine is running." Pages 2 through 10 are set to 'Not Used'. A callout bubble points to the 'Not Used' dropdowns, stating: "Other pages can be configured to be shown, automatically scrolling when the set is running."

5.3.2 CONFIGURABLE EDITOR SCREENS

This is the “Editor” Page which can be configured in the “Advanced “, Section of the PC software. The “Editor” page can be seen once an item has been configured and written back to the module.

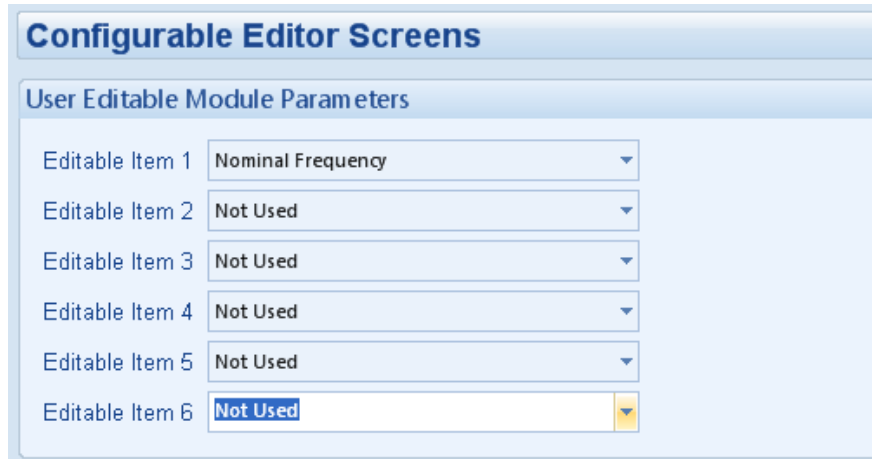

Example – Editor Page

Editor-Generator

Nominal Frequency 50HZ

Press Tick icon button and the parameter will flash.

Press buttons to increase or decrease the value..

Press Tick icon button to save.

NOTE: The following sections detail instrumentation pages, accessible using the scroll left and right buttons, regardless of what pages are configured to be displayed on the ‘status’ screen.

5.3.3 ENGINE

Contains instrumentation gathered about the engine itself, some of which may be obtained using the CAN or other electronic engine link.

- Engine Speed
- Oil Pressure
- Coolant Temperature
- Engine Battery Volts
- Run Time
- Oil Temperature*
- Coolant Pressure*
- Inlet Temperature*
- Exhaust Temperature*
- Fuel Temperature*
- Turbo Pressure*
- Fuel Pressure*
- Fuel Consumption*
- Fuel Used*
- Fuel Level*
- Auxiliary Sensors (If fitted and configured)
- Engine Maintenance Due (If configured)
- Engine ECU Link*

*When connected to suitably configured and compatible engine ECU. For details of supported engines see 'Electronic Engines and DSE wiring' (DSE Part number 057-004).

Depending upon configuration and instrument function, some of the instrumentation items may include a tick  icon beside them. This denotes a further function is available, detailed in the 'operation' section of this document.

Example:

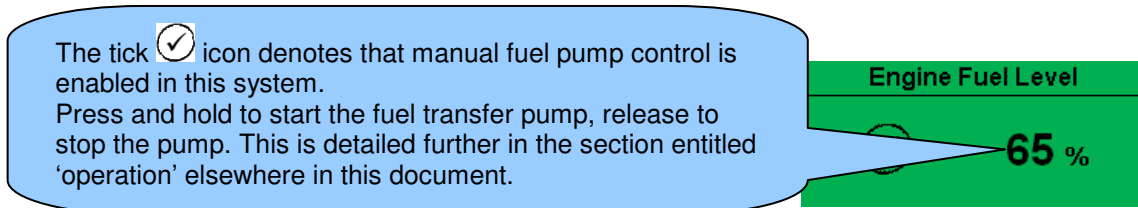

The tick  icon denotes that manual fuel pump control is enabled in this system. Press and hold to start the fuel transfer pump, release to stop the pump. This is detailed further in the section entitled 'operation' elsewhere in this document.

Engine Fuel Level

65 %

5.3.4 GENERATOR

Contains electrical values of the generator (alternator), measured or derived from the module's voltage and current inputs.

- Generator Voltage (ph-N)
- Generator Voltage (ph-ph)
- Generator Frequency
- Generator Current
- Generator Earth Current
- Generator Load (kW)
- Generator Load (kVA)
- Generator Power Factor
- Generator Load (kVAr)
- Generator Load (kWh, kVAh, kVArh)
- Load Demand Priority
- Generator Phase Sequence
- Active Config
- Synchroscope display

5.3.5 BUS

Contains electrical values of the common generator bus measured or derived from the module's bus inputs.

- Bus Voltage (ph-N)
- Bus Voltage (ph-ph)
- Bus Frequency
- Bus Load kW
- Bus Load kVAr
- Bus Phase Sequence

5.3.6 RS232 SERIAL PORT

This section is included to give information about the RS232 serial port and external modem (if connected).

The items displayed on this page will change depending upon configuration of the module. You are referred to your system supplier for further details.

▲NOTE: Factory Default settings are for the RS232 port to be enabled with no modem connected, operating at 19200 baud, modbus slave address 10.

Example 1 – Module connected to an RS232 telephone modem.

When the DSE8610 series module is power up, it will send 'initialisation strings' to the connected modem. It is important therefore that the modem is already powered, or is powered up at the same time as the DSE86xx series module. At regular intervals after power up, the modem is reset, and reinitialised, to ensure the modem does not 'hang up'.

If the DSE8610 series module does not correctly communicate with the modem, "Modem initialising" appears on the Serial Port instrument screen as shown overleaf.

If the module is set for "incoming calls" or for "incoming and outgoing calls", then if the modem is dialled, it will answer after two rings (using the factory setting 'initialisation strings'). Once the call is established, all data is passed from the dialling PC and the DSE8610 series module.

If the module is set for "outgoing calls" or for "incoming and outgoing calls", then the module will dial out whenever an alarm is generated. Note that not all alarms will generate a dial out; this is dependant upon module configuration of the event log. Any item configured to appear in the event log will cause a dial out.

Serial Port	
Baud	9600
SlaveID	10
Modem	



Press down  to view the modem status....

Indicates that a modem is configured. Shows 'RS232' if no modem is configured.

Example 1 continued – Modem diagnostics



Modem diagnostic screens are included; press  when viewing the *RS232 Serial Port* instrument to cycle the available screens. If you are experiencing modem communication problems, this information will aid troubleshooting.

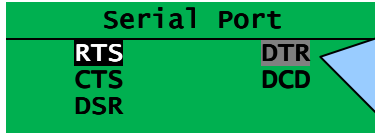

Shows the state of the modem communication lines. These can help diagnose connection problems.

Example:

RTS A dark background shows the line is active.
CTS a grey background shows that the line is toggling high and low.
DSR No background indicates that the line is inactive

Line	Description	
RTS	Request To Send	Flow control
CTS	Clear To Send	Flow control
DSR	Data Set Ready	Ready to communicate
DTR	Data Terminal Ready	Ready to communicate
DCD	Data Carrier Detect	Modem is connected

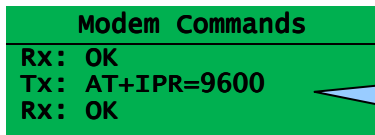

Shows the last command sent to the modem and the result of the command.

Modem Setup Sequence

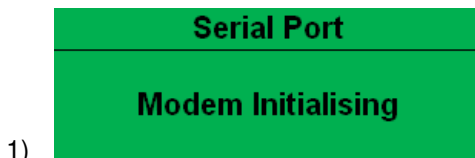

If the Modem and DSE8600 series communicate successfully:

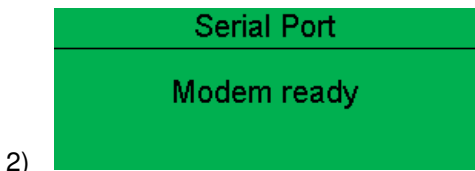

In case of communication failure between the modem and DSE8600 series module, the modem is automatically reset and initialisation is attempted once more:

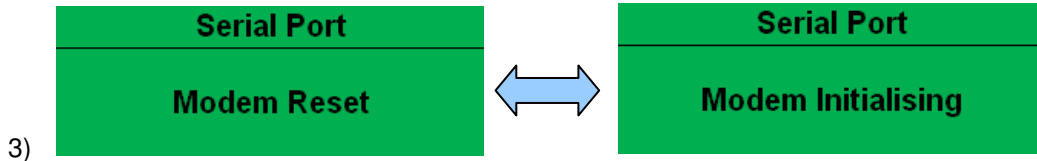

In the case of a module that is unable to communicate with the modem, the display will continuously cycle between 'Modem Reset' and 'Modem Initialising' as the module resets the modem and attempts to communicate with it again, this will continue until correct communication is established with the modem.

In this instance, you should check connections and verify the modem operation.

Example 2 – Module connected to a modem.

Serial Port	
Baud	9600
SlaveID	10
Modem	

Example 3 – Modem status of a GSM modem

Currently connected GSM operator and signal strength.

Serial Port	
Orange	Modem Ready

Many GSM modems are fitted with a status LED to show operator cell status and ringing indicator. These can be a useful troubleshooting tool.

In the case of GSM connection problems, try calling the DATA number of the SIMCARD with an ordinary telephone. There should be two rings, followed by the modem answering the call and then 'squealing'. If this does not happen, you should check all modem connections and double check with the SIM provider that it is a DATA SIM and can operate as a data modem. DATA is NOT the same as FAX or GPRS and is often called Circuit Switched Data (CSD) by the SIM provider.

NOTE: In the case of GSM modems, it is important that a **DATA ENABLED SIM** is used. This is often a different number than the 'voice number' and is often called **Circuit Switched Data (CSD)** by the SIM provider.

If the GSM modem is not purchased from DSE, ensure that it has been correctly set to operate at 9600 baud. You may need to install a terminal program on your PC and consult your modem supplier to do this. GSM modems purchased from DSE are already configured to work with the DSE86xx series module.

5.3.7 RS485 SERIAL PORT

This section is included to give information about the currently selected serial port and external modem (if connected).

The items displayed on this page will change depending upon configuration of the module. You are referred to your system supplier for further details.

NOTE: Factory Default settings are for the RS485 port to operating at 19200 baud, modbus slave address 10.

Module RS485 port configured for connection to a modbus master.

DSE86xx series modules operate as a modbus RTU slave device.

In a modbus system, there can be only one Master, typically a PLC, HMI system or PC SCADA system.

This master requests for information from the modbus slave (DSE86xx series module) and may (in control systems) also send request to change operating modes etc. Unless the Master makes a request, the slave is 'quiet' on the data link.

The factory settings are for the module to communicate at 19200 baud, modbus slave address 10.

Serial Port	
Baud	19200
SlaveID	1
RS485	

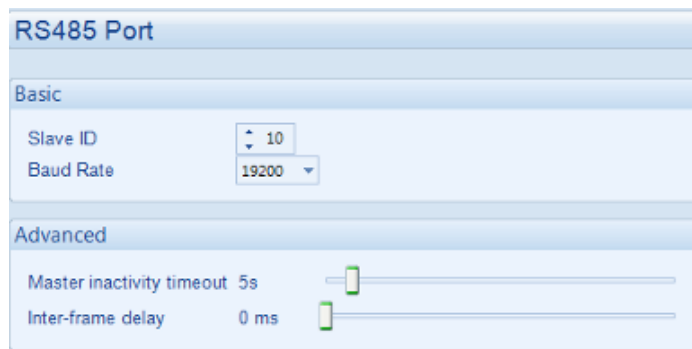

'Master inactivity timeout' should be set to at least twice the value of the system scan time. For example if a modbus master PLC requests data from the DSE86xx modbus slave once per second, the timeout should be set to at least 2 seconds.

The DSE Modbus Gencomm document containing register mappings inside the DSE module is available upon request from support@deepseapl.com. Email your request along with the serial number of your DSE module to ensure the correct information is sent to you.

Typical requests (using Pseudo code)

BatteryVoltage=ReadRegister(10,0405,1) : reads register (hex) 0405 as a single register (battery volts) from slave address 10.

WriteRegister(10,1008,2,35701, 65535-35701) : Puts the module into AUTO mode by writing to (hex) register 1008, the values 35701 (auto mode) and register 1009 the value 65535-35701 (the bitwise opposite of auto mode)

Shutdown=(ReadRegister(10,0306,1) >> 12) & 1) : reads (hex) 0306 and looks at bit 13 (shutdown alarm present)

Warning=(ReadRegister(10,0306,1) >> 11) & 1) : reads (hex) 0306 and looks at bit 12 (Warning alarm present)

ElectricalTrip=(ReadRegister(10,0306,1) >> 10) & 1) : reads (hex) 0306 and looks at bit 11 (Electrical Trip alarm present)

ControlMode=ReadRegister(10,0304,2); reads (hex) register 0304 (control mode).

5.3.8 ABOUT

Contains important information about the module and the firmware versions. This information may be asked for when contacting DSE Technical Support Department for advice.

- Module Type (i.e. 8610)
- Application Version – The version of the module’s main firmware file – Updatable using the Firmware Update Wizard in the DSE Configuration Suite Software.
- USB ID – unique identifier for PC USB connection
- Analogue Measurements software version
- Firmware Update Boot loader software version.

5.3.8.1 ETHERNET PAGES

- Update Network settings using DSE Configuration Suite Software+ 1 Power cycle off/on before the editor pages are updated..

Network
IP address
192.xxx.xx.xx
DHCP Disabled

Network
Subnet mask
255.255.255.0

Network
Gateway address
192.xxx.xx.xxx

Network
DNS address
192.xxx.xx.xx

Network
MAC address
E8.A4.C1.0.A.C2

Unique setting for each module

DHCP
HOST
DOMAIN
Vendor

MODBUS over IP
TCP Port 502
Pref IP 0.0.0.0

Pages available in the “ABOUT” screen to confirm Network settings.

5.3.8.2 DATA LOGGING PAGES

The DSE data logging pages show information depending on the configuration in the module.

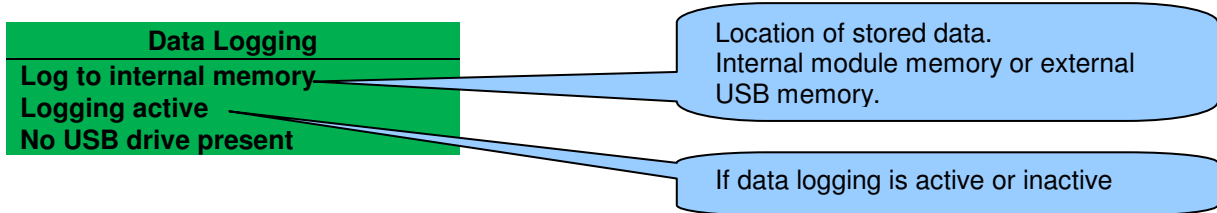

The screenshot shows a green box with the following text: **Data Logging**, **Log to internal memory**, **Logging active**, and **No USB drive present**. Two callout boxes are present: one pointing to the first two lines with the text "Location of stored data. Internal module memory or external USB memory.", and another pointing to the last two lines with the text "If data logging is active or inactive".

Inserting a USB drive to the host USB will display the following change to the page.

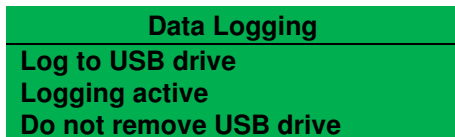

The screenshot shows a green box with the following text: **Data Logging**, **Log to USB drive**, **Logging active**, and **Do not remove USB drive**.

NOTE: Removal of the USB drive should only be carried out using the following method.

Press and hold the  tick button until "Ok to remove USB drive" is displayed.

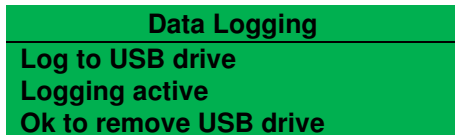

The screenshot shows a green box with the following text: **Data Logging**, **Log to USB drive**, **Logging active**, and **Ok to remove USB drive**.

It is now safe to remove the USB drive.
This ensures the logging data file will save to memory complete and will not become corrupt.

Press down  to view the next page.

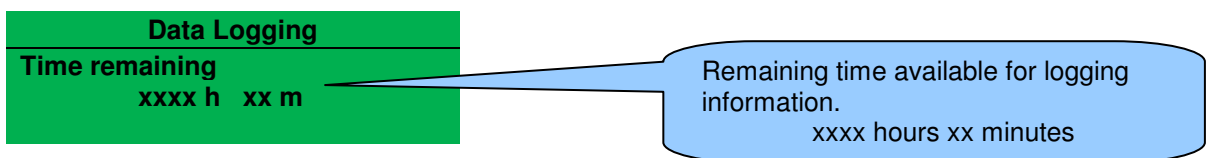

The screenshot shows a green box with the following text: **Data Logging**, **Time remaining**, and **xxxx h xx m**. A callout box points to the time remaining text with the text: "Remaining time available for logging information. xxxx hours xx minutes".

Press down  to view the next page.

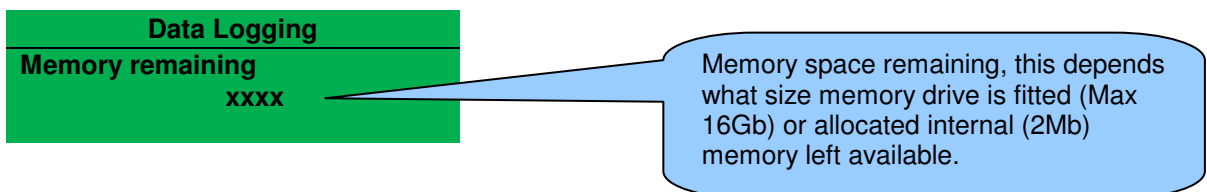

The screenshot shows a green box with the following text: **Data Logging**, **Memory remaining**, and **xxxx**. A callout box points to the memory remaining text with the text: "Memory space remaining, this depends what size memory drive is fitted (Max 16Gb) or allocated internal (2Mb) memory left available."

5.3.9 CAN ERROR MESSAGES

When connected to a suitable CAN engine the 8600 series controller displays alarm status messages from the ECU.

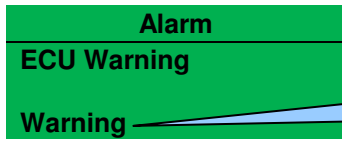

Type of alarm that is triggered in the DSE module (i.e. Warning or Shutdown)



Press  to access the list of current active Engine DTCs (Diagnostic Trouble Codes).

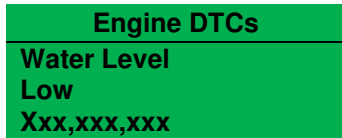

The code interpreted by the module shows on the display as a text message. Additionally, the manufacturer's code is shown.

 **NOTE:** For details on these code meanings, refer to the ECU instructions provided by the engine manufacturer, or contact the engine manufacturer for further assistance.

 **NOTE:** For further details on connection to electronic engines please refer to *Electronic engines and DSE wiring*. Part No. 057-004

5.4 VIEWING THE EVENT LOG

The module maintains a log of past alarms and/or selected status changes.

The log size has been increased in the module over past module updates and is always subject to change. At the time of writing, the 86xx series log is capable of storing the last 250 log entries.

Under default factory settings, the event log only includes shutdown and electrical trip alarms logged (The event log does not contain Warning alarms); however, this is configurable by the system designer using the DSE Configuration Suite software.

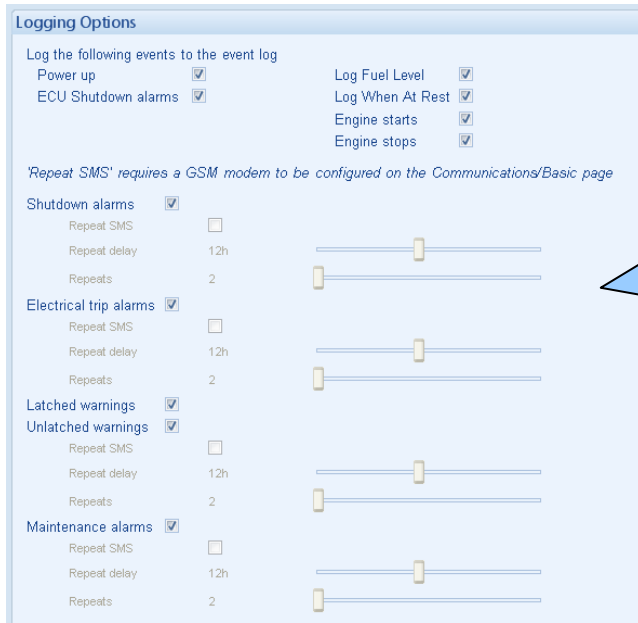

Example showing the possible configuration of the DSE8600 series event log (DSE Configuration Suite Software)

This also shows the factory settings of the module (Only shutdown alarms and the mains status are logged).

Once the log is full, any subsequent shutdown alarms will overwrite the oldest entry in the log. Hence, the log will always contain the most recent shutdown alarms.

The module logs the alarm, along with the date and time of the event (or engine running hours if configured to do so).

If the module is configured and connected to send SMS text



To view the event log, repeatedly press the next page button until the LCD screen displays the Event log :

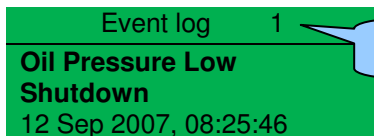

This is event 1.

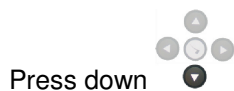

Press down to view the next most recent shutdown alarm:



Continuing to press down cycles through the past alarms after which the display shows the most recent alarm and the cycle begins again.



To exit the event log and return to viewing the instruments, press the next page button to select the next instrumentation page.













5.5 USER CONFIGURABLE INDICATORS

These LEDs can be configured by the user to indicate any one of **100+ different functions** based around the following:-

- **Indications** - Monitoring of a digital input and indicating associated functioning user's equipment - *Such as Battery Charger On or Louvres Open, etc.*
- **WARNINGS and SHUTDOWNS** - Specific indication of a particular warning or shutdown condition, backed up by LCD indication - *Such as Low Oil Pressure Shutdown, Low Coolant level, etc.*
- **Status Indications** - Indication of specific functions or sequences derived from the modules operating state - *Such as Safety On, Pre-heating, Panel Locked, Generator Available, etc.*



5.6 CONTROLS

<p>Stop / Reset This button places the module into its Stop/Reset mode. This will clear any alarm conditions for which the triggering criteria have been removed. If the engine is running and the module is in Stop mode, the module will automatically instruct the changeover device to unload the generator ('Close Generator' becomes inactive (if used)). The fuel supply de-energises and the engine comes to a standstill. Should a remote start signal be present while operating in this mode, a remote start will <u>not</u> occur.</p>	
<p>Manual This mode allows manual control of the generator functions. Once in Manual mode the module will respond to the start  button, start the engine, and run off load. If the engine is running off-load in the Manual mode and a remote start signal becomes present, the module will automatically instruct the changeover device to place the generator on load ('Close Generator' becomes active (if used)). Upon removal of the remote start signal, the generator remains on load until either selection of the 'STOP/RESET' or 'AUTO' modes. <i>For further details, please see the more detailed description of 'Manual operation' elsewhere in this manual.</i></p>	
<p>Auto This button places the module into its 'Automatic' mode. This mode allows the module to control the function of the generator automatically. The module will monitor the <i>remote start</i> input and mains supply status and once a start request is made, the set will be automatically started and placed on load. Upon removal of the starting signal, the module will automatically transfer the load from the generator and shut the set down observing the <i>stop delay</i> timer and <i>cooling</i> timer as necessary. The module will then await the next start event. <i>For further details, please see the more detailed description of 'Auto operation' elsewhere in this manual.</i></p>	
<p>Start This button is only active in STOP/RESET  or MANUAL  mode. Pressing this button in manual or test mode will start the engine and run off load (manual) or on load (test). Pressing this button in STOP/RESET mode will turn on the CAN engine ECU (when correctly configured and fitted to a compatible engine ECU)</p>	
<p>Mute / Lamp Test This button silences the audible alarm if it is sounding and illuminates all of the LEDs as a lamp test feature/ When correctly configured and fitted to a compatible engine ECU, pressing this button in STOP/RESET mode after pressing the START  button (to power the ECU) will cancel any "passive" alarms on the engine ECU.</p>	
<p>Transfer to generator Allows the operator to transfer the load to the generator, synchronising first if required. (when in Manual mode only)</p>	
<p>Open generator (DSE8610 only) Allows the operator to open the generator breaker (when in Manual mode only)</p>	
<p>Menu navigation Used for navigating the instrumentation, event log and configuration screens. For further details, please see the more detailed description of these items elsewhere in this manual.</p>	

6 OPERATION

The following description details the sequences followed by a module containing the standard 'factory configuration'.

Remember that if you have purchased a completed generator set or control panel from your supplier, the module's configuration will probably have been changed by them to suit their particular requirements.

Always refer to your configuration source for the exact sequences and timers observed by any particular module in the field.



6.1 ALTERNATIVE CONFIGURATIONS

Depending upon the configuration of your system by the generator supplier, the system may have selectable configurations (for example to select between 50Hz and 60Hz running). If this has been enabled your generator supplier will advise how this selection can be made (usually by externally operated selector switch or by selecting the required configuration file in the DSE8600 series front panel configuration editor).

6.2 DUMMY LOAD / LOAD SHEDDING CONTROL

This feature may be enabled by the system designer to ensure the loading on the generator is kept to a nominal amount. If the load is low, 'dummy loads' (typically static load banks) can be introduced to ensure the engine is not too lightly loaded. Conversely, as the load increases towards the maximum rating of the set, non-essential loads can be shed to prevent overload of the generator.

6.2.1 DUMMY LOAD CONTROL

The *dummy load control* feature (if enabled) allows for a maximum of five dummy load steps. When the set is first started, all configured *Dummy Load Control* outputs are de-energised. Once the generator is placed onto load, the generator loading is monitored by the *Dummy Load Control* scheme.

If the generator loading falls below the *Dummy Load Control Trip* setting (kW), the *Dummy Load Control Trip Delay* is displayed on the module display. If the generator loading remains at this low level for the duration of the timer, the first *Dummy Load Control* output is energised. This is used to energise external circuits to switch in (for instance) a static load bank.

The generator loading has now been increased by the first dummy load. Again, the generator loading is monitored.

This continues until all configured *Dummy Load Control* outputs are energised.

Should the generator loading rise above the *Dummy Load Return* level, the *Dummy Load Return Delay* begins.

If the loading remains at these levels after the completion of the timer, the 'highest' active *Dummy Load Control* output is de-energised. This continues until all *Dummy Load Control* outputs have been de-energised.

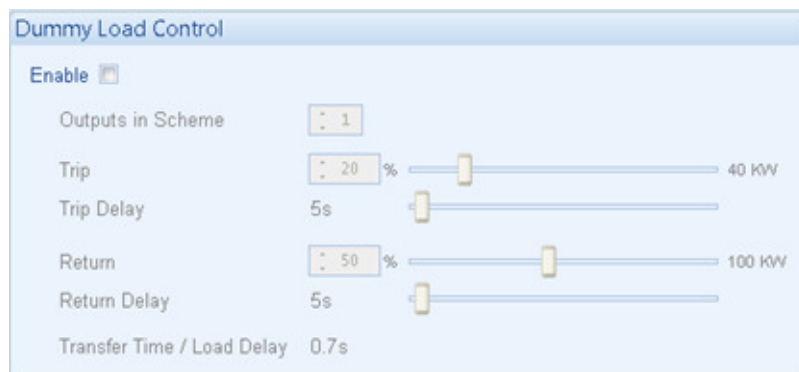

Example screen shot of *Dummy Load Control* setup in the DSE Configuration Suite

6.2.2 LOAD SHEDDING CONTROL

The *Load Shedding Control* feature (if enabled) allows for a maximum of five load-shedding steps. When the generator is about to take load, the configured number of *Load Shedding Control Outputs at Startup* will energise. This configurable setting allows (for instance) certain loads to be removed from the generator prior to the set's load switch being closed. This can be used to ensure the initial loading of the set is kept to a minimum, below the *Load Acceptance* specification of the generating set.

The generator is then placed on load. The *Load Shedding Control* scheme begins.

When the load reaches the *Load Shedding Trip* level, the *Trip Delay* timer will start. If the generator loading is still high when the timer expires, the first *Load shedding Control* output will energise. When the load has been above the trip level for the duration of the timer the 'next' *Load shedding Control* output will energise and so on until all *Load Shedding Control* outputs are energised.

If at any time the load falls back below the *Load Shedding Return* level, the *Return Time* will start. If the load remains below the return level when the timer has expired the 'highest' *Load Shedding Control* output that has been energised will be de-energised. This process will continue until all outputs have been de-energised.

When the set enters a stopping sequence for any reason the *Load Shedding control* outputs will de-energise at the same time as the generator load switch is signalled to open.

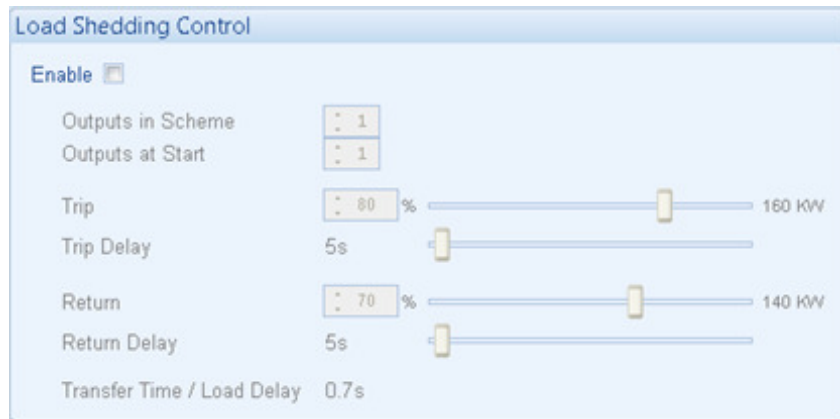

Example screen shot of *Load Shedding Control* setup in the DSE Configuration Suite

6.3 SMS CONTROL

NOTE: Only available in version DSE86xx version 5.1+ modules with a suitable GSM modem connected to the RS232 port and configured to receive the control commands.

The *SMS Control* feature (if enabled) allows the user to send control commands to a DSE86xx via SMS message. There are five control commands that the user can send to the module, these control commands are in the table below.

NOTE: Multiple SMS Control Commands CANNOT be sent in a single SMS message.

Control Command Number	Module Action
1	Start the generator off load if in the 'Auto' position.
2	Start the generator on load if in the 'Auto' position..
3	Cancel an SMS start request.
4	Put the module into the 'STOP' position.
5	Put the module into the 'AUTO' position.

To send an SMS command, the user will need (if configured) the *SMS Control Pin Number* and the *Control Command Number*. Only these numbers must be included in the SMS, the module will not respond to any SMS with extra characters or missing PIN number (if configured). Below is an example how to start and run the generator on load by SMS message.

NOTE: There must be a space between the *SMS PIN Number* and the *Control Command Number*

The diagram illustrates four SMS messages with callouts identifying the Pin Number and Control Command Number components. Callout boxes are labeled 'Pin Number' and 'Control Command Number'.

- SMS Message 1:** 0123 5. This SMS message will place the module into the AUTO position.
- SMS Message 2:** 0123 2. This SMS message will start and run the generator on load..
- SMS Message3:** 0123 3. This SMS message will remove the start and run command given by the previous SMS message and leave the module in the AUTO position
- SMS Message 4:** 0123 4. This SMS message will place the module into the STOP position.

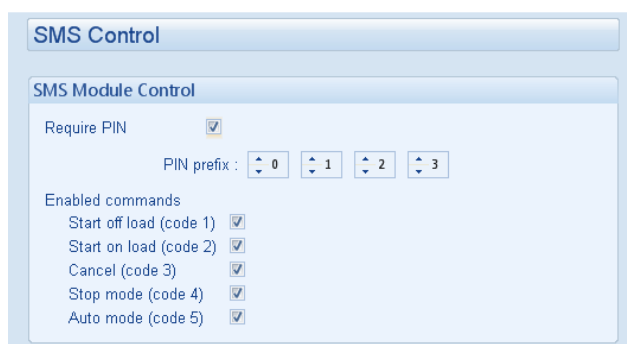

Example screen shot of *SMS Control* setup in the DSE Configuration Suite

6.4 STOP MODE

STOP mode is activated by pressing the  button.

NOTE: *Enable Cool Down in Stop Mode* option has been added to version 6.0

In STOP mode, the module will immediately remove the generator from load (if necessary) before stopping the engine if it is already running.

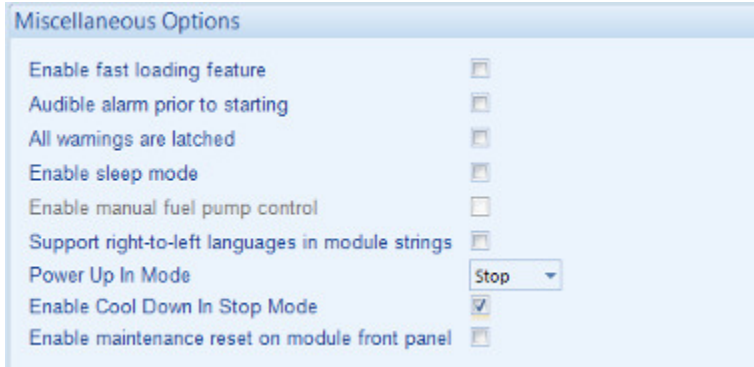

- If *Cool Down in Stop Mode* not enabled, no cooling run is provided for this operation. Where a cooling run is required, switch to MANUAL mode and open the breaker manually. Allow the set to cool off load, before pressing the STOP button to stop the engine.
- If *Cool Down in Stop Mode* enabled, cooling run is provided for this operation. The set will run off load for the amount of time configured in *Load/Stopping Timers, Cooling Time* before the set is stopped.

If the engine does not stop when requested, the FAIL TO STOP alarm is activated (subject to the setting of the *Fail to Stop* timer). To detect the engine at rest the following must occur:

- Engine speed is zero as detected by the Magnetic Pickup or CANbus ECU (depending upon module variant).
- Generator frequency must be zero.
- Oil pressure switch must be closed to indicate low oil pressure (MPU version only)

When the engine has stopped, it is possible to send configuration files to the module from DSE Configuration Suite PC software and to enter the Front Panel Editor to change parameters.

Any latched alarms that have been cleared will be reset when STOP mode is entered.

The engine will not be started when in STOP mode. If remote start signals are given, the input is ignored until AUTO mode is entered.

When configured to do so, when left in STOP mode for five minutes with no presses of the fascia buttons, the module enters low power mode. To 'wake' the module, press the  button or any other fascia control button.

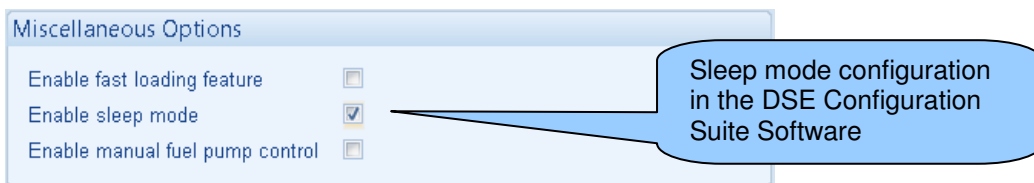



6.4.1 ECU OVERRIDE

▲NOTE: Depending upon system design, the ECU may be powered or unpowered when the module is in STOP mode. ECU override is only applicable if the ECU is unpowered when in STOP mode.

When the ECU is powered down (as is normal when in STOP mode), it is not possible to read the diagnostic trouble codes or instrumentation. Additionally, it is not possible to use the engine manufacturers' configuration tools.

As the ECU is usually unpowered when the engine is not running, it must be turned on manually as follows:

- Select STOP  mode on the DSE controller.
- Press and hold the START  button to power the ECU. As the controller is in STOP mode, the engine will not be started.
- Continue to hold the start button for as long as you need the ECU to be powered.
- The ECU will remain powered until a few seconds after the START button is released.

This is also useful if the engine manufacturer's tools need to be connected to the engine, for instance to configure the engine as the ECU needs to be powered up to perform this operation.

6.5 AUTOMATIC MODE

 **NOTE: If a digital input configured to *panel lock* is active, changing module modes will not be possible. Viewing the instruments and event logs is NOT affected by panel lock.**

Activate auto mode by pressing the  pushbutton. An LED indicator beside the button confirms this action.

Auto mode will allow the generator to operate fully automatically, starting and stopping as required with no user intervention.

6.5.1 WAITING IN AUTO MODE

If a starting request is made, the starting sequence will begin. Starting requests can be from the following sources:

- Activation of an auxiliary input that has been configured to *remote start on load* or *remote start off load*. or *Remote Start Dead Bus Synchronising* (see elsewhere in this manual)
- Request from DSE8660 mains controller or from another DSE8610 controller over the MSC link.
- Activation of the inbuilt exercise scheduler.
- Instruction from external remote telemetry devices using the RS232 or RS485 interface.

6.5.2 STARTING SEQUENCE

To allow for 'false' start requests such as mains brownouts, the *start delay* timer begins. There are individual start delay timers for each of the different start request types.

Should all start requests be removed during the *start delay* timer, the unit will return to a stand-by state.

If a start request is still present at the end of the *start delay* timer, the fuel relay is energised and the engine will be cranked.

 **NOTE: If the unit has been configured for CAN, compatible ECU's will receive the start command via CAN.**

If the engine fails to fire during this cranking attempt then the starter motor is disengaged for the *crank rest* duration after which the next start attempt begins. Should this sequence continue beyond the set number of attempts, the start sequence will be terminated and the display shows **Fail to Start**.

The starter motor is disengaged when the engine fires. Speed detection is factory configured to be derived from the main alternator output frequency, but can additionally be measured from a Magnetic Pickup mounted on the flywheel (Selected by PC using the 8600 series configuration software).

Additionally, rising oil pressure or charge alternator voltage can be used to disconnect the starter motor (but cannot detect underspeed or overspeed).

 **NOTE: If the unit has been configured for CAN, speed sensing is via CAN.**

After the starter motor has disengaged, the *Safety On* timer activates, allowing Oil Pressure, High Engine Temperature, Under-speed, Charge Fail and any delayed Auxiliary fault inputs to stabilise without triggering the fault.

6.5.3 ENGINE RUNNING

Once the engine is running, the *Warm Up* timer, if selected, begins, allowing the engine to stabilise before accepting the load.

If the common bus is measured to be 'dead bus', the load breaker is closed.

If the bus is measured to be 'live bus', synchronising takes place before the breaker is closed.

 **NOTE: The load transfer signal remains inactive until the Oil Pressure has risen. This prevents excessive wear on the engine.**

As the load increases and decreases, the DSE86xx series module (may (depending upon configuration) add dummy loads or remove non-essential loads. This is configured as part of the *Load Shedding* and *Dummy Load* control settings in the DSE Configuration Suite Software. See section entitled *Dummy Load / Load Shedding* elsewhere in this document for further details.

Additionally, when configured as part of a multiset package, the generator may be automatically started and stopped depending upon load requirements.

If in doubt, consult your system supplier for details of how your particular system has been configured.

If all start requests are removed, the *stopping sequence* will begin.

6.5.4 STOPPING SEQUENCE

The *return delay* timer operates to ensure that the starting request has been permanently removed and is not just a short-term removal. Should another start request be made during the cooling down period, the set will return on load.

If there are no starting requests at the end of the *return delay* timer, the load is ramped off the generator being the breaker is opened and the *cooling* timer is initiated.

The *cooling* timer allows the set to run off load and cool sufficiently before being stopped. This is particularly important where turbo chargers are fitted to the engine.

If the set is called to return to load before the *cooling timer* has expired, the *Engine Running* operation is again followed.

After the *cooling* timer has expired, the set is stopped.

6.6 MANUAL MODE

▲ NOTE: If a digital input configured to *panel lock* is active, changing module modes will not be possible. Viewing the instruments and event logs is NOT affected by panel lock.

Activate Manual mode by pressing the  pushbutton. An LED indicator beside the button confirms this action.

Manual mode allows the operator to start and stop the set manually, and if required change the state of the load switching devices.

6.6.1 WAITING IN MANUAL MODE

When in manual mode, the set will not start automatically.

To begin the starting sequence, press the  button.

6.6.2 STARTING SEQUENCE

▲ NOTE: There is no *start delay* in this mode of operation.

The fuel relay is energised and the engine is cranked.

▲ NOTE: If the unit has been configured for CAN, compatible ECU's will receive the start command via CAN.

If the engine fails to fire during this cranking attempt then the starter motor is disengaged for the *crank rest* duration after which the next start attempt is made. Should this sequence continue beyond the set number of attempts, the start sequence will be terminated and the display shows **Fail to Start**.

When the engine fires, the starter motor is disengaged. Speed detection is factory configured to be derived from the main alternator output frequency but can additionally be measured from a Magnetic Pickup mounted on the flywheel (Selected by PC using the 8600 series configuration software).

Additionally, rising oil pressure or charge alternator voltage can be used to disconnect the starter motor (but cannot detect underspeed or overspeed).

▲ NOTE: If the unit has been configured for CAN, speed sensing is via CAN.

After the starter motor has disengaged, the *Safety On* timer activates, allowing Oil Pressure, High Engine Temperature, Under-speed, Charge Fail and any delayed Auxiliary fault inputs to stabilise without triggering the fault.

6.6.3 ENGINE RUNNING

In manual mode, the load is not transferred to the generator unless a 'loading request' is made. A loading request can come from a number of sources.

- Pressing the *transfer to generator*  button.
- Request from DSE8660 mains controller or from another DSE8610 controller over the MSC link.
- Activation of an auxiliary input that has been configured to *remote start on load*
- Activation of the inbuilt exercise scheduler if configured for 'on load' runs.

▲NOTE: The load transfer signal remains inactive until the Oil Pressure has risen. This prevents excessive wear on the engine.





If the common bus is measured to be 'dead bus', the load breaker is closed.

If the bus is measured to be 'live bus', synchronising takes place before the breaker is closed.





Once the load has been transferred to the generator, the load switch will not be automatically opened unless:

- Press the *Open Generator* button (DSE8610/DSE8610 only)
- Press the *auto mode*  button to return to automatic mode.

6.6.4 MANUAL FUEL PUMP CONTROL



- Navigate to the instruments page using the  buttons and locate FUEL LEVEL.  is shown on the module display to indicate that this feature is available.
- Press and hold the  button to energise the transfer pump. The pump starts two seconds after the button is pressed.
- Release the  button to de-energise the transfer pump.

6.6.5 MANUAL SPEED CONTROL

- Navigate to the instruments page using the  buttons and locate ENGINE SPEED.  is shown on the module display to indicate that this feature is available.
- Press the  button to enter edit mode
- Press  (up or down) to change the engine speed.
- Press the  button again to exit the editor and leave the engine running at the newly selected speed.

6.6.6 STOPPING SEQUENCE

In manual mode the set will continue to run until either :

- The *stop button*  is pressed – The set will immediately stop if *Coolddown in Stop Mode* is disabled, or the set will go to *cooldown* if *Coolddown in Stop Mode* is enabled and will stop until the *Cooling Time* timer expires.
- The *auto button*  is pressed. The set will observe all auto mode start requests and stopping timers before beginning the *Auto mode stopping sequence*.

7 DEAD BUS SYNCHRONISING (AUTO MODE)

Generator set specifications often contain the requirement for the set to be on load within 15 seconds of a mains supply failure. This is easily achievable in single set applications. However in the current era of fuel conservation, multiple sets are often used to provide the backup power solution for many applications. This gives challenges in starting and synchronising the required sets before they can be used to power the load.

The solution to this is a longstanding one, having being used for many decades. However modern digital communications such as the DSE MSC link has vastly improved the control and hence safety of the system operation. The solution is called “Dead Bus Synchronising”

7.1 OPERATION

Before the generator sets are started, the load switches are closed. This requires DC controlled breakers. Next, the alternator excitation field is disconnected from the AVR and the engines are started.

Once running satisfactorily, the AVR is reconnected to the excitation field and load sharing begins. The MSC link is used to ensure all sets excite the alternator at exactly the same time. Any sets not up to speed before the end of the “Excitation Delay” timer are instructed to open their breakers. A short time later, these sets synchronise to the bus in the traditional manner.

7.2 DEAD BUS SYNCHRONISING

During Dead bus synchronising a Start is issued from Mains control panel

Status	
Start Delay	00:00 s

The Generator Breaker is closed ,
Excitation is switched off, start delay if
configured.

Status	
Fuel	

Fuel Output Activated

Status	
Crank Attempt	

Engine Cranked

Status		
Excitation Delay	00:03	
L-N	V	A
L-L	V	50 Hz
	kW	Pf

Excitation delay before excitation output
is activated. Generators run up to speed
if any on the MSC are out of limits they
are instructed to open their breaker and
synchronise in the normal manner.

Status		
Excitation Ramp		
L-N	V	A
L-L	V	Hz
	kW	Pf

Excitation output closed voltage
rises to nominal settings.

Status	
On Load	

Once the voltage and frequency
are within configurable limits the
set(s) can take load.

7.3 HARDWARE REQUIREMENTS

- DSE8610 V5.0 controller or higher.
- DC controlled generator breaker.
- Auxiliary contact to feed back generator breaker status to the DSE controller.
- External relay driven by the DSE module to control the excitation of the alternator.

8 PROTECTIONS

When an alarm is present, the Audible Alarm will sound and the Common alarm LED if configured will illuminate.

The audible alarm can be silenced by pressing the *Mute button* 

The LCD display will jump from the 'Information page' to display the Alarm Page

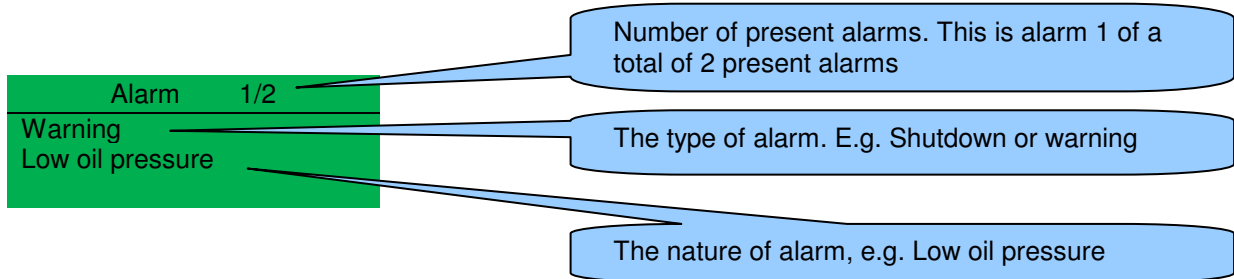

The LCD will display multiple alarms E.g. "High Engine Temperature shutdown", "Emergency Stop" and "Low Coolant Warning". These will automatically scroll in the order that they occurred.

In the event of a warning alarm, the LCD will display the appropriate text. If a shutdown then occurs, the module will again display the appropriate text.

Example:-

Alarm	1/2
Warning	Oil pressure Low

Alarm	2/2
Shutdown	Coolant Temperature High

8.1 PROTECTIONS DISABLED

User configuration is possible to prevent Shutdown / Electrical Trip alarms from stopping the engine. Under such conditions, *Protections Disabled* will appear on the module display to inform the operator of this status.

This feature is provided to assist the system designer in meeting specifications for “Warning only”, “Protections Disabled”, “Run to Destruction”, “War mode” or other similar wording.

When configuring this feature in the PC software, the system designer chooses to make the feature either permanently active, or only active upon operation of an external switch. The system designer provides this switch (not DSE) so its location will vary depending upon manufacturer, however it normally takes the form of a key operated switch to prevent inadvertent activation. Depending upon configuration, a warning alarm may be generated when the switch is operated.

The feature is configurable in the PC configuration software for the module. Writing a configuration to the controller that has “Protections Disabled” configured, results in a warning message appearing on the PC screen for the user to acknowledge before the controller’s configuration is changed. This prevents inadvertent activation of the feature.

8.1.1 INDICATION / WARNING ALARMS

Under Indication or Warning alarms:

- The module operation is unaffected by the *Protections Disabled* feature. See sections entitled *Indications* and *Warnings* elsewhere in this document.

8.1.2 SHUTDOWN / ELECTRICAL TRIP ALARMS

 **NOTE: The EMERGENCY STOP input and shutdown alarm continues to operate even when *Protections Disabled* has been activated.**

Under Shutdown or Electrical Trip alarm conditions (excluding Emergency Stop):

- The alarm is displayed on the screen as detailed in the section entitled *Shutdown alarms* elsewhere in this document.
- The set continues to run.
- The load switch maintains its current position (it is not opened if already closed)
- **Shutdown Blocked** also appears on the LCD screen to inform the operator that the Protections Disabled feature has blocked the shutdown of the engine under the normally critical fault.
- The ‘shutdown’ alarm is logged by the controllers *Event Log* (if configured to log shutdown alarms) and logs that the Shutdown was prevented.

8.2 INDICATIONS

Indications are non-critical and often status conditions. They do not appear on the LCD of the module as a text message. However, an output or LED indicator can be configured to draw the operator's attention to the event.

Example

- Input configured for indication.
- The LCD text will not appear on the module display but can be added in the configuration to remind the system designer what the input is used for.
- As the input is configured to *Indication* there is no alarm generated.
- LED Indicator to make LED1 illuminate when Digital Input A is active.
- The Insert Card Text allows the system designer to print an insert card detailing the LED function.
- Sample showing operation of the LED.

Digital Input A

Function: User Configured

Polarity: Close to Activate

Action: Indication

Arming: Always

LCD Display: Battery Charger On

Activation Delay: 0s

LED Indicators

ID	Input	Status	Insert Card Text
1	Digital Input A	Lit	Battery Charger On



8.3 WARNINGS

Warnings are non-critical alarm conditions and do not affect the operation of the generator system, they serve to draw the operators attention to an undesirable condition.

Example

Alarm 1/1
Charge Failure Warning

In the event of an alarm the LCD will jump to the alarms page, and scroll through all active warnings and shutdowns.

By default, warning alarms are self-resetting when the fault condition is removed. However enabling 'all warnings are latched' will cause warning alarms to latch until reset manually. This is enabled using the 8600 series configuration suite in conjunction with a compatible PC.

Display	Reason
CHARGE FAILURE	The auxiliary charge alternator voltage is low as measured from the W/L terminal.
BATTERY UNDER VOLTAGE	The DC supply has fallen below the low volts setting level for the duration of the low battery volts timer
BATTERY OVER VOLTAGE	The DC supply has risen above the high volts setting level for the duration of the high battery volts timer
FAIL TO STOP	The module has detected a condition that indicates that the engine is running when it has been instructed to stop. <div style="border: 1px solid black; padding: 5px; margin-top: 10px;">  NOTE:- 'Fail to Stop' could indicate a faulty oil pressure sensor or switch - If the engine is at rest check oil sensor wiring and configuration. </div>
FUEL USAGE	Indicates the amount of fuel measured by the fuel level sensor is in excess of the <i>Fuel Usage</i> alarm settings. This often indicates a fuel leak or potential fuel theft.
AUXILIARY INPUTS	Auxiliary inputs can be user configured and will display the message as written by the user.
LOW FUEL LEVEL	The level detected by the fuel level sensor is below the low fuel level setting.
CAN ECU ERROR	The engine ECU has detected a warning alarm and has informed the DSE module of this situation. The exact error is also indicated on the module's display.
KW OVERLOAD	The measured Total kW is above the setting of the kW overload warning alarm
EARTH FAULT	The measured Earth Fault Current has been in excess of the earth fault trip and has surpassed the IDMT curve of the Earth Fault alarm.
NEGATIVE PHASE SEQUENCE	Indicates 'out of balance' current loading of the generator. Sometimes also called Negative Sequence Current or Symmetry Fault
MAINTENANCE DUE	Indicates that the maintenance alarm has triggered. A visit is required by the Generator service company.
LOADING VOLTAGE NOT REACHED	Indicates that the generator voltage is not above the configured <i>loading voltage</i> . The generator will not take load when the alarm is present after the safety timer.
LOADING FREQUENCY NOT REACHED	Indicates that the generator frequency is not above the configured <i>loading frequency</i> . The generator will not take load when the alarm is present after the safety timer.

Display	Reason
PROTECTIONS DISABLED	Shutdown and electrical trip alarms can be disabled by user configuration. In this case, Protections Disabled will appear on the module display; The alarm text is displayed but the engine will continue to run. This is 'logged' by the module to allow DSE Technical Staff to check if the protections have been disabled on the module at any time. This feature is available from V4 onwards.
LOW OIL PRESSURE	The module detects that the engine oil pressure has fallen below the low oil pressure pre-alarm setting level after the <i>Safety On</i> timer has expired.
ENGINE HIGH TEMPERATURE	The module detects that the engine coolant temperature has exceeded the high engine temperature pre-alarm setting level after the <i>Safety On</i> timer has expired.
ENGINE LOW TEMPERATURE	The module detects that the engine coolant temperature has fallen below the high engine temperature pre-alarm setting level.
OVERSPEED	The engine speed has risen above the overspeed pre alarm setting
UNDERSPEED	The engine speed has fallen below the underspeed pre alarm setting
GENERATOR OVER FREQUENCY	The generator output frequency has risen above the pre-set pre-alarm setting.
GENERATOR UNDER FREQUENCY	The generator output frequency has fallen below the pre-set pre-alarm setting after the <i>Safety On</i> timer has expired.
GENERATOR OVER VOLTAGE	The generator output voltage has risen above the pre-set pre-alarm setting.
GENERATOR UNDER VOLTAGE	The generator output voltage has fallen below the pre-set pre-alarm setting after the <i>Safety On</i> timer has expired.
ECU WARNING	The engine ECU has detected a warning alarm and has informed the DSE module of this situation. The exact error is also indicated on the module's display.

If the module is configured for, **CAN** and receives an "error" message from the engine control unit, 'Can ECU Warning' is shown on the module's display and a warning alarm is generated.

8.4 HIGH CURRENT WARNING ALARM

GENERATOR HIGH CURRENT, if the module detects a generator output current in excess of the pre-set trip a warning alarm initiates. The module shows Alarm Warning High Current. If this high current condition continues for an excess period, then the alarm escalates to a shutdown condition. For further details of the high current alarm, please see High Current Shutdown Alarm.

By default, High Current Warning Alarm is self-resetting when the overcurrent condition is removed. However enabling 'all warnings are latched' will cause the alarm to latch until reset manually. This is enabled using the 8600 series configuration suite in conjunction with a compatible PC.

8.5 SHUTDOWNS

NOTE: Shutdown and Electrical Trip alarms can be disabled by user configuration. See the section entitled *Protections Disabled* elsewhere in this document.

Shutdowns are latching alarms and stop the Generator. Clear the alarm and remove the fault then press Stop/Reset  to reset the module.

Example

Alarm	1/1
Oil Pressure Low Shutdown	

NOTE: The alarm condition must be rectified before a reset will take place. If the alarm condition remains, it will not be possible to reset the unit (The exception to this is the Low Oil Pressure alarm and similar 'active from safety on' alarms, as the oil pressure will be low with the engine at rest).

Display	Reason
EARTH FAULT	The measured Earth Fault Current has been in excess of the earth fault trip and has surpassed the IDMT curve of the Earth Fault alarm.
FAIL TO START	The engine has not fired after the preset number of start attempts
EMERGENCY STOP	The emergency stop button has been depressed. This is a failsafe (normally closed to battery positive) input and will immediately stop the set should the signal be removed. Removal of the battery positive supply from the emergency stop input will also remove DC supply from the Fuel and Start outputs of the controller. NOTE: The Emergency Stop Positive signal must be present otherwise the unit will shutdown.
LOW OIL PRESSURE	The engine oil pressure has fallen below the low oil pressure trip setting level after the <i>Safety On</i> timer has expired.
ENGINE HIGH TEMPERATURE	The engine coolant temperature has exceeded the high engine temperature trip setting level after the <i>Safety On</i> timer has expired.
FUEL USAGE	Indicates the amount of fuel measured by the fuel level sensor is in excess of the <i>Fuel Usage</i> alarm settings. This often indicates a fuel leak or potential fuel theft.
PHASE ROTATION	The phase rotation is measured as being different to the configured direction.
OVERSPEED	The engine speed has exceeded the pre-set trip NOTE: During the start-up sequence, the overspeed trip logic can be configured to allow an extra trip level margin. This is used to prevent nuisance tripping on start-up - Refer to the 8600 series configuration software manual under heading 'Overspeed Overshoot' for details.

Protections

Display	Reason
UNDERSPEED	The engine speed has fallen below the pre-set trip after the Safety On timer has expired.
GENERATOR OVER FREQUENCY	The generator output frequency has risen above the preset level
GENERATOR UNDER FREQUENCY	The generator output frequency has fallen below the preset level
GENERATOR OVER VOLTAGE	The generator output voltage has risen above the preset level
GENERATOR UNDER VOLTAGE	The generator output voltage has fallen below the preset level
OIL PRESSURE SENSOR OPEN CIRCUIT	The oil pressure sensor is detected as not being present (open circuit)
AUXILIARY INPUTS	An active auxiliary input configured as a shutdown will cause the engine to shut down. The display shows the text as configured by the user.
LOSS OF SPEED SIGNAL	The DSE controller is not receiving the speed signal from the magnetic pickup.
ECU DATA FAIL	The module is configured for CAN operation and does not detect data on the engine Can data link, the engine shuts down.
ECU SHUTDOWN	The engine ECU has detected a shutdown alarm and has informed the DSE module of this situation. The exact error is also indicated on the module's display.
KW OVERLOAD	The measured Total kW is above the setting of the kW overload shutdown alarm
NEGATIVE PHASE SEQUENCE	Indicates 'out of balance' current loading of the generator. Sometimes also called Negative Sequence Current or Symmetry Fault
MAINTENANCE DUE	Indicates that the maintenance alarm has triggered. A visit is required by the Generator service company.
GENERATOR HIGH CURRENT	A High Current condition has continued for an excess period, then the alarm escalates to either a shutdown or electrical trip condition (depending upon module configuration). For further details of the high current alarm, please see High Current Shutdown / Electrical Trip Alarm.
LOADING VOLTAGE NOT REACHED	Indicates that the generator voltage is not above the configured <i>loading voltage</i> after the safety timer. The generator will shutdown.
LOADING FREQUENCY NOT REACHED	Indicates that the generator frequency is not above the configured <i>loading frequency</i> after the safety timer. The generator will shutdown.
PROTECTIONS DISABLED	Shutdown and electrical trip alarms can be disabled by user configuration. In this case, Protections Disabled will appear on the module display; The alarm text will be displayed but the engine will continue to run. This is 'logged' by the module to allow DSE Technical Staff to check if the protections have been disabled on the module at any time. This feature is available from V4 onwards.

8.6 ELECTRICAL TRIPS

NOTE: Shutdown and Electrical Trip alarms can be disabled by user configuration. See the section entitled *Protections Disabled* elsewhere in this document.

Electrical trips are latching and stop the Generator but in a controlled manner. On initiation of the electrical trip condition the module will de-energise the ‘Close Generator’ Output to remove the load from the generator. Once this has occurred the module will start the Cooling timer and allow the engine to cool off-load before shutting down the engine. The alarm must be accepted and cleared, and the fault removed to reset the module.

Example

Alarm	1/1
Generator Current High Electrical Trip	

Electrical trips are latching alarms and stop the Generator. Remove the fault then press Stop/Reset  to reset the module.

Display	Reason
GENERATOR HIGH CURRENT	If a generator output in excess of the high current alarm point, a warning alarm occurs. If this high current condition continues for an excess period, then the alarm escalates to either a shutdown or electrical trip condition (depending upon module configuration). For further details of the high current alarm, please see High Current Shutdown / Electrical Trip Alarm.
AUXILIARY INPUTS	If an auxiliary input configured as an electrical trip is active, the user configured message shows on the display.
kW OVERLOAD	The measured Total kW is above the setting of the kW overload Electrical Trip alarm
EARTH FAULT	The measured Earth Current is above the setting of the Earth fault alarm.
NEGATIVE PHASE SEQUENCE	Indicates ‘out of balance’ current loading of the generator. Sometimes also called Negative Sequence Current or Symmetry Fault
FUEL USAGE	Indicates the amount of fuel used is in excess of the <i>Fuel Usage</i> alarm settings. This often indicates a fuel leak or potential fuel theft.
LOADING VOLTAGE NOT REACHED	Indicates that the generator voltage is not above the configured loading voltage after the safety timer. The generator will shutdown.
LOADING FREQUENCY NOT REACHED	Indicates that the generator frequency is not above the configured loading frequency after the safety timer. The generator will shutdown.
PROTECTIONS DISABLED	Shutdown and electrical trip alarms is disabled by user configuration. In this case, Protections Disabled will appear on the module display; The alarm text is displayed but the engine will continue to run. This is ‘logged’ by the module to allow DSE Technical Staff to check if the protections have been disabled on the module at any time. This feature is available from V4 onwards.
GENERATOR UNDER FREQUENCY	The generator output frequency has fallen below the preset level
GENERATOR UNDER VOLTAGE	The generator output voltage has fallen below the preset level

Protections

Display	Reason
MSC OLD UNITS ON BUS	If the module detects a module on the MSC link which is incompatible with the current module, then the MSC Compatibility alarm will be triggered. Check all the modules' version numbers (under <i>About Application Number</i> on the modules' displays), modules pre V3 cannot communicate with modules V4 and onwards. Use the DSE Configuration Suite Software to upgrade the firmware (<i>Tools Update Firmware</i>) of the older modules to V4 and onwards. V5.0 cannot communicate with older modules and V5.1 saw a change where Dse 55xx and 75xx series communicate with 86xx range of modules, therefore all 86xx need to be at V5.0+ to communicate on the same MSC link.
UNDERSPEED	The engine speed has fallen below the underspeed setting

8.7 OVER CURRENT ALARM

The overcurrent alarm combines a simple warning trip level with a fully functioning IDMT curve for thermal protection.

8.7.1 IMMEDIATE WARNING

If the *Immediate Warning* is enabled, the DSE8600 Series controller generates a *warning alarm* as soon as the *Trip* level is reached. The alarm automatically resets once the generator loading current falls below the *Trip* level (unless *All Warnings are latched* is enabled). For further advice, consult your generator supplier.

8.7.2 IDMT ALARM

If the *IDMT Alarm* is enabled, the DSE8600 Series controller begins following the IDMT 'curve' when the *trip* level is passed.

If the *Trip* is surpassed for an excess amount of time the *IDMT Alarm* triggers (*Shutdown* or *Electric trip* as selected in *Action*).

High current shutdown is a latching alarm and stops the Generator.

Remove the fault then press Stop/Reset  to reset the module.

High current electrical trip is a latching alarm and removes the generator from the load, before stopping the Generator after the off load *cooling* timer.

Remove the fault then press Stop/Reset  to reset the module.

The higher the overload, the faster the trip. The speed of the trip is dependent upon the fixed formula:

$$T = t / ((I_A / I_T) - 1)^2$$

Where: T is the tripping time in seconds

I_A is the actual current of the most highly loaded line (L1 or L2 or L3)

I_T is the delayed over-current trip point

t is the time multiplier setting and also represents the tripping time in seconds at twice full load (when $I_A / I_T = 2$).

Factory settings for the *IDMT Alarm* when used on a brushless alternator are as follows (screen capture from the DSE Configuration Suite PC software):

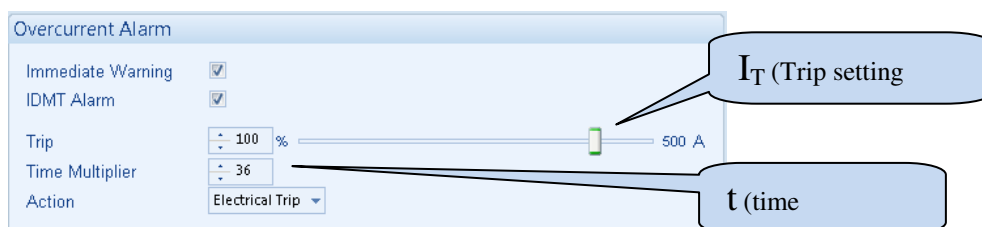

These settings provide for normal running of the generator up to 100% full load. If full load is surpassed, the *Immediate Warning* alarm is triggered, the set continues to run.

The effect of an overload on the generator is that the alternator windings begin to overheat; the aim of the *IDMT alarm* is to prevent the windings being overloaded (heated) too much. The amount of time that the set can be safely overloaded is governed by how high the overload condition is.

Protections

With typical settings as above, the tripping curve is followed as shown below.

This allows for overload of the set to the limits of the *Typical Brushless Alternator* whereby 110% overload is permitted for 1 hour.

If the set load reduces, the controller then *follows* a cooling curve. This means that a second overload condition may trip much sooner than the first as the controller *knows* if the windings have not cooled sufficiently.

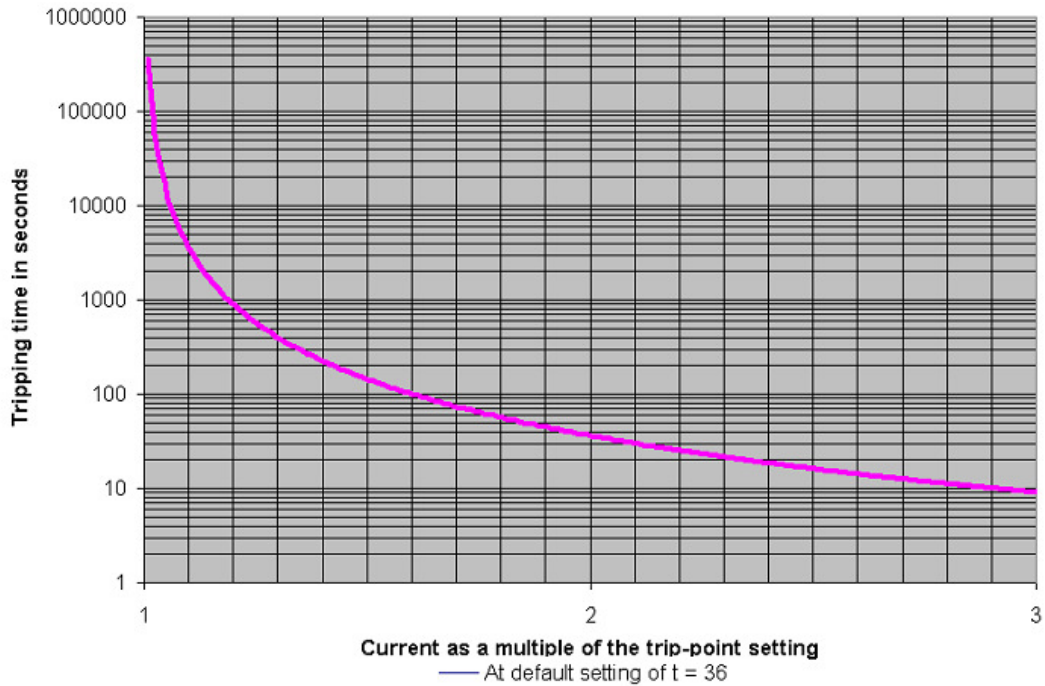

For further details on the *Thermal damage curve* of your alternator, you are referred to your alternator manufacturer and generator supplier.

8.8 SHORT CIRCUIT AND EARTH FAULT ALARM

When the module is suitably connected using the 'Earth Fault CT'. The module measures Earth Fault and can optionally be configured to generate an alarm condition (shutdown or electrical trip) when a specified level is surpassed.

Short Circuit alarm operates in the same way as the Earth Fault, using the same curve formula, but typically uses a lower value for K (time multiplier) to give a faster acting trip.

If the *Alarm* is enabled, the DSE8610 Series controller begins following the IDMT 'curve'. If the current surpasses the *Trip* for an excess of time, the Alarm triggers (*Shutdown* or *Electric trip* as selected in *Action*).

The higher the fault, the faster the trip. The speed of the trip is dependent upon the fixed formula:

$$T = K \times 0.14 / ((I / I_s)^{0.02} - 1)$$

Where: T is the tripping time in seconds (accurate to +/- 5% or +/- 50ms (whichever is the greater)
 K is the time multiplier setting
 I is the actual earth current measured
 I_s is the trip setting value

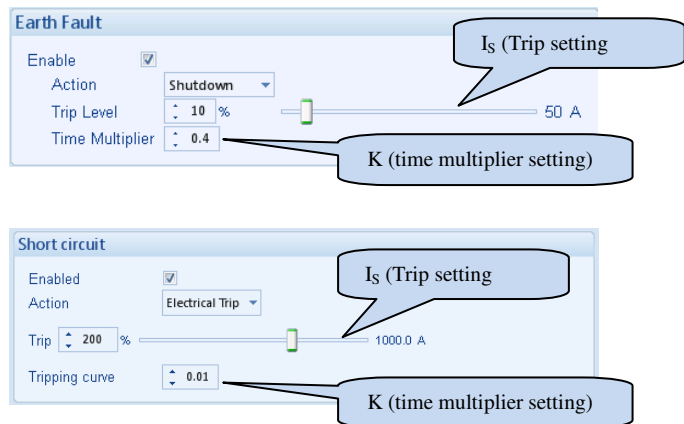

The settings shown in the example above are a screen capture of the DSE factory settings, taken from the DSE Configuration Suite software.

8.8.1 EARTH FAULT TRIPPING CURVES

NOTE: DSE Factory setting is time multiplier (K) = 0.4

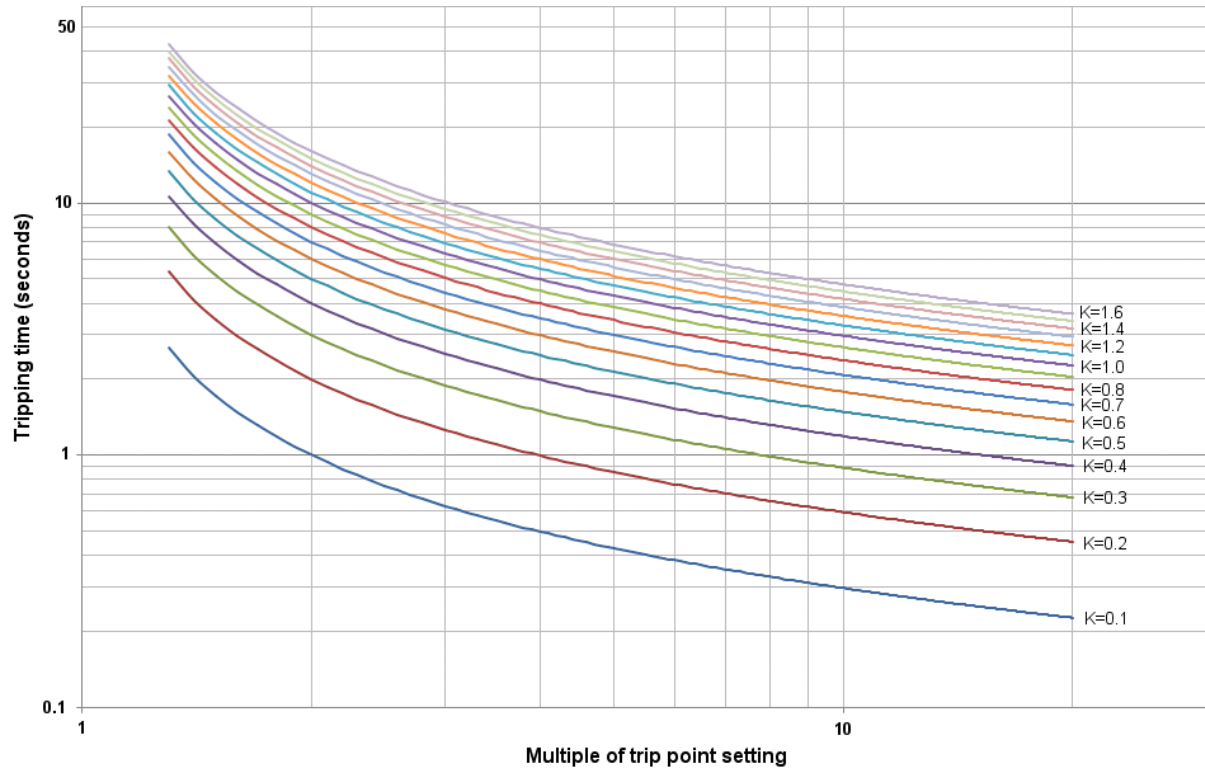

8.8.2 SHORT CIRCUIT TRIPPING CURVES

NOTE: DSE Factory setting is time multiplier (K) = 0.01

**Trip time
(mS)**

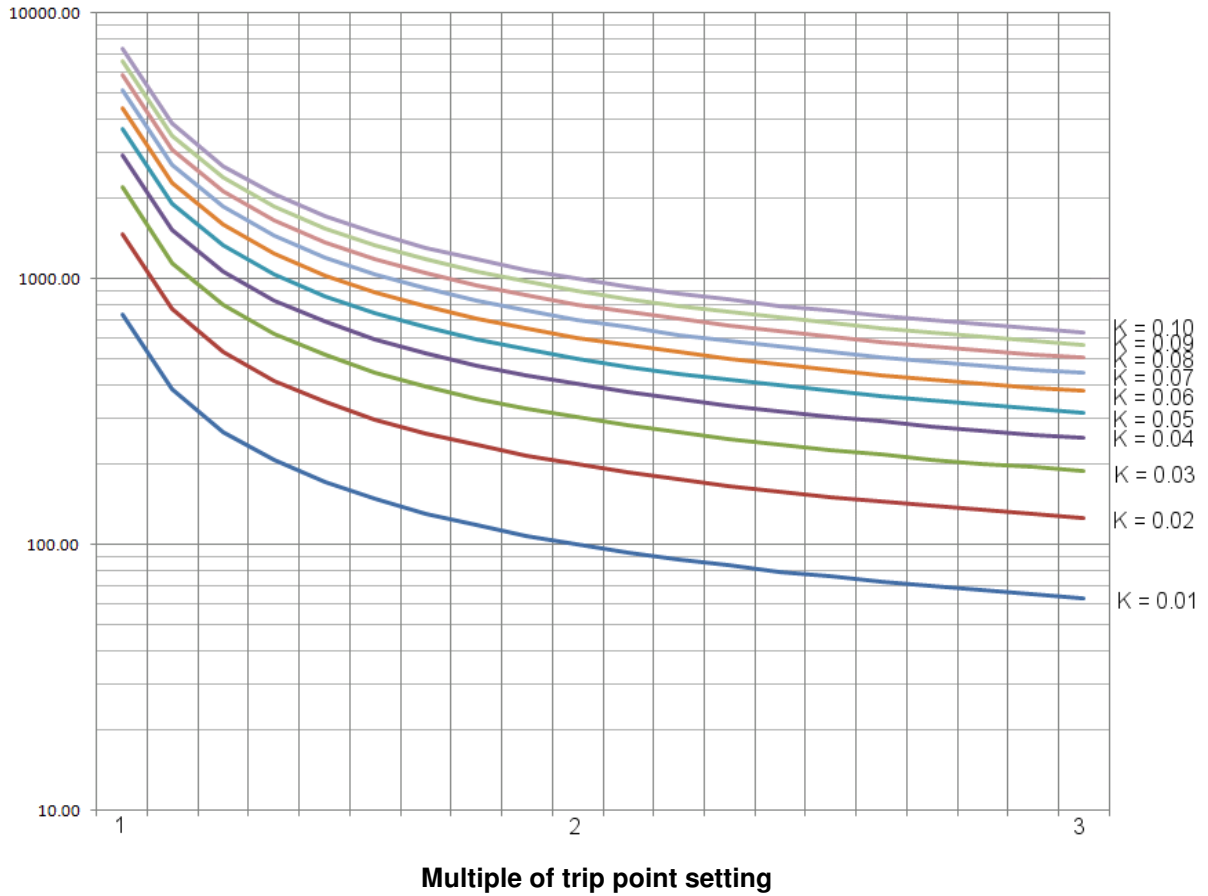



8.9 ROCOF / VECTOR SHIFT

When configured to run in parallel with the mains (utility) supply, the module monitors for ROCOF / Vector shift trips according to the module's configuration settings. This is included within the module and will detect failure of the mains supply during parallel operation with the generator.

▲ NOTE: This protection operates only when in parallel with the mains supply and is disabled at all other times.

Should either of these alarms operate, the module will perform a controlled shutdown (electrical trip) of the generator. This operation must be manually reset :

- 1) Press  button. The engine will stop if it is still running and the alarm is cleared.
- 2) Activate digital input configured to "Clear ROCOF/Vector shift" if this has been provided.
- 3) Press  and  button together and hold for 5 seconds. The ROCOF/Vector shift instrument is displayed and all 'peak hold' values are reset, clearing the ROCOF/Vector shift alarm.

For details on activating and configuring the ROCOF/Vector shift protection, you are referred to the 8600 configuration software manual.

9 MAINTENANCE ALARM

Depending upon module configuration one or more levels of maintenance alarm may occur based upon a configurable schedule.

There are three maintenance alarms in the DSE86xx/DSE86xx series V3 and above, and one level of maintenance alarm in prior versions.

Example 1

Screen capture from DSE Configuration Suite Software showing the configuration of Maintenance Alarm 1 and Maintenance Alarm 2.

When activated, the maintenance alarm can be either a **warning** (set continues to run) or **shutdown** (running the set is not possible).

The site service engineer normally performs resetting the maintenance alarm after performing the required maintenance.

The screenshot displays the 'Maintenance Alarm' configuration window. It is divided into two sections: 'Maintenance alarm 1' and 'Maintenance alarm 2'. Each section has the following fields:

- Enable:** A checked checkbox.
- Description:** A text box containing 'Maintenance alarm 1' (for alarm 1) and 'Maintenance alarm 2' (for alarm 2).
- Action:** A dropdown menu set to 'Warning'.
- Engine run hours:** A numeric input field with '10' (for alarm 1) and '250' (for alarm 2) and a unit of 'hrs'. A slider bar is visible to the right.
- Enable alarm on due date:** An unchecked checkbox.
- Maintenance interval:** A numeric input field with '1' and a unit of 'months'. A slider bar is visible to the right.

The method of reset is either by:

- Activating an input that has been configured to maintenance x reset, where x is the number of the maintenance alarm (1 to 3).
- Pressing the maintenance reset button in the DSE Configuration Suite, Maintenance section.
- Maintenance reset on module front panel, on the display Engine, maintenance alarm x, by pressing the Stop button till it resets.

Example 2

Screen capture from DSE Configuration Suite Software showing the configuration of a digital input for Reset Maintenance Alarm 1.

The screenshot displays the 'Digital Input A' configuration window. It has the following fields:

- Function:** A dropdown menu set to 'Reset maintenance alarm 1'.
- Polarity:** A dropdown menu set to 'Close to Activate'.
- Action:** A dropdown menu.
- Arming:** A dropdown menu.
- LCD Display:** A text box.
- Activation Delay:** A slider bar with '0s' indicated.

Maintenance Alarm

Example 3

Screen capture from DSE Configuration Suite Software showing the Maintenance Alarm Reset 'button' in the DSE Configuration Suite SCADA | MAINTENANCE section.



Example 4

Screen capture from DSE8610 Front Panel, Engine Display, Maintenance Alarm 1. Press the Stop button till the Maintenance Alarm is reset.



10 SCHEDULER

DSE8600 Series contains an inbuilt exercise run scheduler, capable of automatically starting and stopping the set. Up to 16 scheduled start/stop sequences can be configured to repeat on a 7-day or 28-day cycle.

Scheduled runs may be on load or off load depending upon module configuration.

Example

Screen capture from DSE Configuration Suite Software showing the configuration of the Exercise Scheduler.

In this example the set will start at 09:00 on Monday and run for 5 hours, then start at 13:30 on Tuesday and run for 30 minutes.

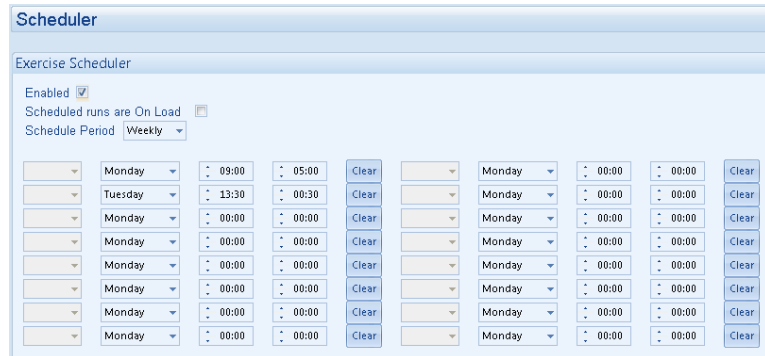

10.1 STOP MODE

- Scheduled runs will not occur when the module is in STOP/RESET mode.

10.2 MANUAL MODE

- Scheduled runs will not occur when the module is in MANUAL mode.
- Activation of a Scheduled Run 'On Load' when the module is operating OFF LOAD in Manual mode will have no effect, the set continues to run OFF LOAD

10.3 AUTO MODE

- Scheduled runs will operate ONLY if the module is in AUTO mode with no Shutdown or Electrical Trip alarm present.
- If the module is in STOP or MANUAL mode when a scheduled run begins, the engine is not started. However, if the module moves into AUTO mode during a scheduled run, the engine is called to start.
- Depending upon configuration by the system designer, an external input can be used to inhibit a scheduled run.
- If the engine is running OFF LOAD in AUTO mode and a scheduled run configured to 'On Load' begins, the set is placed ON LOAD for the duration of the Schedule.

11 FRONT PANEL CONFIGURATION

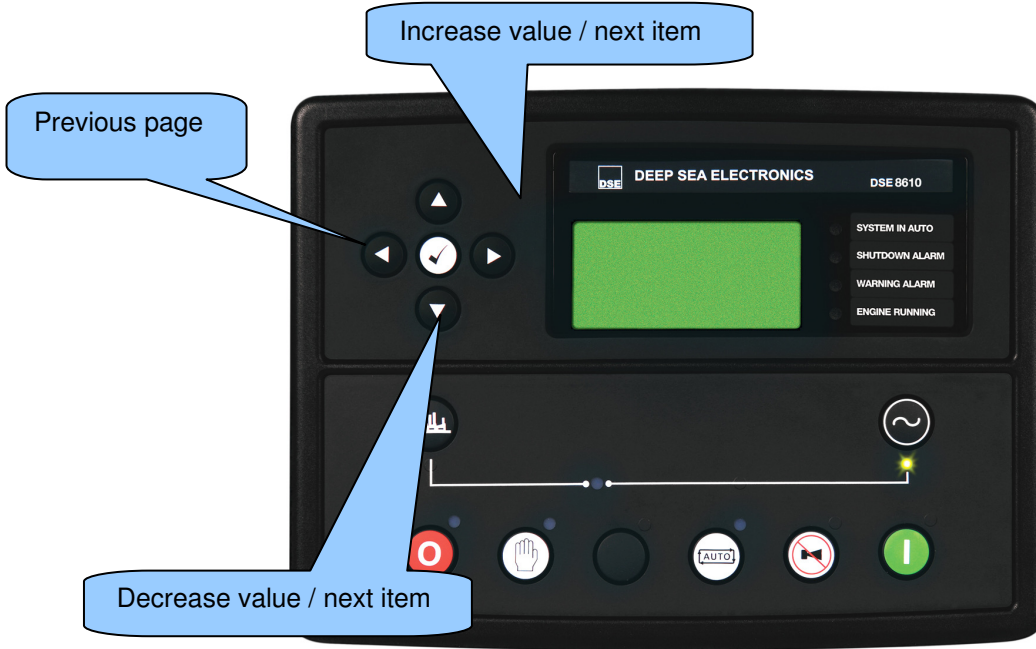

This configuration mode allows the operator limited customising of the way the module operates.

Use the module's navigation buttons to traverse the menu and make value changes to the parameters:



11.1 ACCESSING THE MAIN FRONT PANEL CONFIGURATION EDITOR

Ensure the engine is at rest and the module is in STOP mode by pressing the Stop/Reset  button.

Press the Stop/Reset  and Info  buttons simultaneously.
If a module security PIN has been set, the PIN number request is then shown :

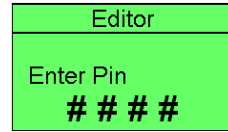

Press , the first '#' changes to '0'. Press  (up or down) to adjust it to the correct value.

Press  (right) when the first digit is correctly entered. The digit you have just entered will now show '#' for security.

Repeat this process for the other digits of the PIN number. You can press  (left) if you need to move back to adjust one of the previous digits.

When  is pressed after editing the final PIN digit, the PIN is checked for validity. If the number is not correct, you must re-enter the PIN.

If the PIN has been successfully entered (or the module PIN has not been enabled), the editor is displayed :

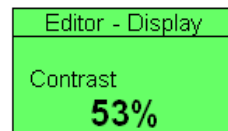



NOTE: The PIN number is not set by DSE when the module leaves the factory. If the module has a PIN code set, this has been affected by your generator supplier who should be contacted if you require the code. If the code has been 'lost' or 'forgotten', the module must be returned to the DSE factory to have the module's code removed. A charge will be made for this procedure.

NB - This procedure cannot be performed away from the DSE factory.

11.1.1 EDITING A PARAMETER

Enter the editor as described above.

Press the  (left) or  (right) buttons to cycle to the section you wish to view/change.

Press the  (up or down) buttons to select the parameter you wish to view/change within the currently selected section.

To edit the parameter, press  to enter edit mode. The parameter begins to flash to indicate that you are editing the value.

Press the  (up or down) buttons to change the parameter to the required value.

Press  to save the value. The parameter ceases flashing to indicate that it has been saved.

To exit the editor at any time, press and hold the  button.

▲NOTE: The editor automatically exits after 5 minutes of inactivity to ensure security.

▲NOTE: The PIN number is automatically reset when the editor is exited (manually or automatically) to ensure security.

▲ NOTE: More comprehensive module configuration is possible using the 86xx series PC configuration software. Please contact us for further details.

11.1.2 ADJUSTABLE PARAMETERS

Front Panel Configuration Editor. For descriptions of the parameters, you are referred to The DSE8600 series Configuration Suite Manual, DSE Part 057-119.

Section	Parameter as shown on display	Values	
Display	Contrast	53%	
	Language	English, others.	
	Current Date and Time	hh:mm	
Timers	LCD Page Timer	5m	
	Scroll Delay	2s	
	Engine Pre Heat Timer	0s	
	Engine Crank Duration	10s	
	Engine Crank Rest Time	10s	
	Engine Safety On Delay	10s	
	Engine Smoke Limiting	0s	
	Engine Smoke Limiting Off	0s	
	Engine warm Up Time	1s	
	Engine Cool Down Time	1m	
	Engine Speed Overshoot Delay	0s	
	Engine Failed To Stop	30s	
	Battery Under Voltage warning Delay	1m	
	Battery Over Voltage warning Delay	1m	
	Return Delay	30s	
	Generator Transient Delay	0s	
	Generator	Under Voltage Shutdown	184v
		Under Voltage Pre-Alarm	196v
		Loading Voltage	207
		Nominal Voltage	230v
Over Voltage Pre-Alarm		265v	
Over Voltage Shutdown		277v	
Under Frequency Shutdown		40Hz	
Under Frequency Pre-Alarm		42Hz	
Short Circuit Trip		200%	
Loading Frequency		45Hz	
Nominal Frequency		50Hz	
Over Frequency Pre-Alarm		54Hz	
Over Frequency Shutdown		57Hz	
Full Load Rating		500A	
KW Overload Trip		100%	
Delayed Over current		Active	
Gen Over Current Trip		100%	
AC System		3 Phase 4 wire	
CT Primary		600A	
CT Secondary		5A	
Short Circuit Trip		200%	
Earth CT Primary		500A	
Earth Fault Trip		Active	
Earth Fault Trip		10%	
Transient Delay		0s	
Gen Reverse Power Delay		2s	
Full kw rating		345kw	
Full kVAR rating		258kVAR	
Load Ramp Rate		3%	
Load Level For More Sets		80%	
Load Level For Less Sets		70%	
Load Demand Priority		1	
Gen Reverse Power Trip		35kw	
Gen Over Current		0%	
Insufficient Capacity Delay		1s	
Insufficient Capacity Action		None	
Reactive Load CTL Mode VAR Share		None	
Load Parallel Power		172kw when In Mains Parallel Mode	
Load Power factor		0% when In Mains Parallel Mode	
Enable 75/55 MSC Compatibility		Inactive	
Engine	Oil Pressure Low shutdown	1.03bar	
	Oil Pressure Low Pre-Alarm	1.17bar	
	Coolant Temp High Pre-Alarm	90°C	
	Coolant Temp High Electrical Trip	92°C	
	Coolant Temp High Shutdown	95°C	
	Start Delay Off load	5s	
	Start Delay on load	5s	
	Start Delay mains fail	0s	
	Start Delay Telemetry	5s	
	Pre Heat Timer	0s	
	Crank Duration	10s	
	Crank rest Time	10s	
	Safety On Delay	10s	
	Smoke Limiting	0s	
	Smoke limiting off	0s	
	warm Up Time	1s	
	Cool Down Time	1m	
	Speed Overshoot Delay	0s	
	Speed Overshoot	0%	
	Fail To Stop Delay	30s	
	Battery Under Volts warning	Active	
	Battery Under Volts warning Delay	1m	
	Battery Under Volts warning	19v	
	Battery Over Volts warning	Active	
	Battery Over Volts warning Delay	1m	
	Battery Over Volts warning	30v	
	Charge Alternator Failure warning	Active	
	Charge Alternator Failure warning	6.0v	
	Charge Alternator warning Delay	5s	
	Charge Alternator Failure Shutdown	Active	
Charge Alternator Failure Shutdown	4.0		
Charge Alternator Shutdown Delay	5s		
Scheduler	droop %	Active, Inactive. Electronic engines only when droop is enabled.	
	Scheduler	Active, Inactive	
	Schedule On Load	Active, Inactive (Only Available when Scheduler is Active)	
	Schedule Period	weekly, Monthly (Only Available when Scheduler is Active)	
	Schedule Time & Date Selection (1-16)	Press to begin editing then press or when selecting the different parameters in the scheduler.	



11.2 ACCESSING THE 'RUNNING' CONFIGURATION EDITOR

The 'running' editor can be entered while the engine is running. All protections remain active if the engine is running while the running editor is entered.

Press and hold the  button to enter the running editor.

11.2.1 EDITING A PARAMETER

Enter the editor as described above.

Press the  (left) or  (right) buttons to cycle to the section you wish to view/change.

Press the  (up or down) buttons to select the parameter you wish to view/change within the currently selected section.

To edit the parameter, press  to enter edit mode. The parameter begins to flash to indicate that you are editing the value.

Press the  (up or down) buttons to change the parameter to the required value.

Press  to save the value. The parameter ceases flashing to indicate that it has been saved.

To exit the editor at any time, press and hold the  button.

11.2.2 ADJUSTABLE PARAMETERS (RUNNING EDITOR)

Running Editor (Factory default settings are shown in bold italicised text)

Section	Parameter as shown on display	Factory Setting
DISPLAY	Contrast	53%
	Language	English
	Load Demand priority	(1)
	Load Power factor	0-100% (0)
	Load parallel power	0-100% (50)
	Enable commissioning screens	Inactive, Active
	Override starting alarms	Inactive, Active
	Voltage adjust (manual mode only engine running breaker open)	0-100 % (0)
	Frequency adjust (manual mode only engine running breaker open)	0-100 % (0)
	Enable mains decoupling test mode (stop mode only)	Inactive Active

12 COMMISSIONING

12.1 PRE-COMMISSIONING

Before the system is started, it is recommended that the following checks are made:-

- 10.1. The unit is adequately cooled and all the wiring to the module is of a standard and rating compatible with the system. Check all mechanical parts are fitted correctly and that all electrical connections (including earths) are sound.
- 10.2. The unit **DC** supply is fused and connected to the battery and that it is of the correct polarity.
- 10.3. The Emergency Stop input is wired to an external **normally closed** switch connected to **DC positive**.

 **NOTE: If Emergency Stop feature is not required, link this input to the DC Positive. The module will not operate unless either the Emergency Stop is fitted correctly OR terminal 3 is connected to DC positive.**

- 10.4. Make all checks on the engine and alternator as detailed by their respective manufacturer documentation.
- 10.5. Check all other parts in the system according to the manufacturer documentation.
- 10.6. Thoroughly review the configuration of the DSE controller and check that all parameters meet the requirements of your system.
- 10.7. To check the start cycle operation, take appropriate measures to prevent the engine from starting (disable the operation of the fuel solenoid). After a visual inspection to ensure it is safe to proceed, connect the battery supply. Select “**MANUAL**” and then press “**START**” the unit start sequence will commence.
- 10.8. The starter will engage and operate for the pre-set crank period. After the starter motor has attempted to start the engine for the pre-set number of attempts, the LCD will display ‘Failed to start’. Select the **STOP/RESET** position to reset the unit.
- 10.9. Restore the engine to operational status (reconnect the fuel solenoid). Select “**MANUAL**” and then press “**START**”. This time the engine will start and the starter motor will disengage automatically. If not then check the engine is fully operational (fuel available, etc.) and the fuel solenoid is operating. The engine will now run up to operating speed. If not, and an alarm is present, check the alarm condition for validity, and check input wiring. The engine will continue to run for an indefinite period. At this time to view the engine and alternator parameters - refer to the ‘Description of Controls’ section of this manual.
- 10.10. Fully commission the engine/alternator and any other parts in the system as detailed in the respective manufacturer documentation. This includes load bank testing, load acceptance, breaker control and more.
- 10.11. When building a synchronising system, follow the DSE “4 Steps To Synchronising” as detailed elsewhere in this document before attempting to parallel the set with another supply.
- 10.12. Set the modules internal clock/calendar to ensure correct operation of the scheduler and event logging functions. For details of this procedure see section entitled *Front Panel Configuration – Editing the date and time*.
- 10.13. If despite repeated checking of the connections between the **8600** series controller and the customer’s system, satisfactory operation cannot be achieved, then the customer is requested to contact the factory for further advice on:-

INTERNATIONAL TEL: +44 (0) 1723 890099

INTERNATIONAL FAX: +44 (0) 1723 893303

E-mail: support@deepseapl.com

Website : www.deepseapl.com

13 FAULT FINDING

SYMPTOM	POSSIBLE REMEDY
Unit is inoperative Read/Write configuration does not operate	Check the battery and wiring to the unit. Check the DC supply. Check the DC fuse.
Unit shuts down	Check DC supply voltage is not above 35 Volts or below 9 Volts Check the operating temperature is not above 70°C. Check the DC fuse.
Unit locks out on Emergency Stop	If no Emergency Stop Switch is fitted, ensure that a DC positive signal is connected to the Emergency Stop input. Check emergency stop switch is functioning correctly. Check Wiring is not open circuit.
Intermittent Magnetic Pick-up sensor fault	Ensure that Magnetic pick-up screen only connects to earth at one end, if connected at both ends, this enables the screen to act as an aerial and will pick up random voltages. Check pickup is correct distance from the flywheel teeth.
Low oil Pressure fault operates after engine has fired	Check engine oil pressure. Check oil pressure switch/sensor and wiring. Check configured polarity (if applicable) is correct (i.e. Normally Open or Normally Closed) or that sensor is compatible with the 73x0 Module and is correctly configured.
High engine temperature fault operates after engine has fired.	Check engine temperature. Check switch/sensor and wiring. Check configured polarity (if applicable) is correct (i.e. Normally Open or Normally Closed) or that sensor is compatible with the 8600 series module.
Shutdown fault operates	Check relevant switch and wiring of fault indicated on LCD display. Check configuration of input.
Warning fault operates	Check relevant switch and wiring of fault indicated on LCD display. Check configuration of input.
Fail to Start is activated after pre-set number of attempts to start	Check wiring of fuel solenoid. Check fuel. Check battery supply. Check battery supply is present on the Fuel output of the module. Check the speed-sensing signal is present on the 8600 series module's inputs. Refer to engine manual.
Continuous starting of generator when in AUTO	Check that there is no signal present on the "Remote Start" input. Check configured polarity is correct.
Generator fails to start on receipt of Remote Start signal.	Check Start Delay timer has timed out. Check signal is on "Remote Start" input. Confirm correct configuration of input Check that the oil pressure switch or sensor is indicating low oil pressure to the controller. Depending upon configuration, then set will not start if oil pressure is not low.
Pre-heat inoperative	Check wiring to engine heater plugs. Check battery supply. Check battery supply is present on the Pre-heat output of module. Check pre-heat configuration is correct.
Starter motor inoperative	Check wiring to starter solenoid. Check battery supply. Check battery supply is present on the Starter output of module. Ensure that the Emergency Stop input is at Positive. Ensure oil pressure switch or sensor is indicating the "low oil pressure" state to the 8610 series controller.
Engine runs but generator will not take load	Check Warm up timer has timed out. Ensure generator load inhibit signal is not present on the module inputs. Check connections to the switching device. Note that the set will not take load in manual mode unless there is an active remote start on load signal.
Synchronising or load sharing is not operating satisfactorily	Follow the DSE "4 Steps To Synchronising" as detailed in the following section.

SYMPTOM	POSSIBLE REMEDY
<p>Incorrect reading on Engine gauges</p> <p>Fail to stop alarm when engine is at rest</p>	<p>Check engine is operating correctly. Check sensor and wiring paying particular attention to the wiring to terminal 47 (refer to appendix). Check that sensor is compatible with the 8600 series module and that the module configuration is suited to the sensor.</p>
<p>Module appears to 'revert' to an earlier configuration</p>	<p>When editing a configuration using the PC software it is vital that the configuration is first 'read' from the controller before editing it. This edited configuration must then be "written" back to the controller for the changes to take effect.</p> <p>When editing a configuration using the fascia editor, be sure to press the Accept  button to save the change before moving to another item or exiting the fascia editor</p>
<p>Set will not take load</p>	<p>Ensure the generator available LED is lit</p> <p>Check that the output configuration is correct to drive the load switch device and that all connections are correct.</p> <p>Remember that the set will not take load in manual mode unless a remote start on load input is present or the close generator button is pressed.</p>
<p>Inaccurate generator measurements on controller display</p>	<p>Check that the CT primary, CT secondary and VT ratio settings are correct for the application.</p> <p>Check that the CTs are wired correctly with regards to the direction of current flow (p1,p2 and s1,s2) and additionally ensure that CTs are connected to the correct phase (errors will occur if CT1 is connected to phase 2).</p> <p>Remember to consider the power factor. I.e (kW = kVA x power factor)</p> <p>The 8600 series controller is true RMS measuring so gives more accurate display when compared with an 'averaging' meter such as an analogue panel meter or some lower specified digital multimeters.</p> <p>Accuracy of the controller is better than 1% of full scale. I.e. Gen volts full scale is 333V ph-n so accuracy is $\pm 3.33V$ (1% of 333V).</p>

 **NOTE: The above fault finding is provided as a guide check-list only. As the module is configurable for a range of different features, always refer to the source of your module configuration if in doubt.**

14 DSE 4 STEPS TO SUCCESSFUL SYNCHRONISING

Synchronising and load sharing is often considered to be a complex subject. In fact, it is very simple when broken down into smaller steps.

After following the *Commissioning* section of this manual, the *4 Steps* **must** be followed before any parallel operation is attempted.

The following information is a *short form* guide only, intended as a memory jogger once the steps are fully understood.

The full video presentation of the *4 Steps* is available on the DSE website. www.deepseapl.com. Registration on the website is required. This is free of charge, along with all other downloads.

This page is also available as a training document (handout style) from DSE. Part Number 056-001 Four Steps to Synchronising – included on the DSE website.

14.1 CONTROL

Check the control of the engine is working:

- Control of AVR
- Control of Governor
- Direction of Control

Failure of the above steps will result in poor control of the governor/AVR leading to problems during synchronising and/or load sharing if not corrected.

14.2 METERING

- CTs on the Right Phase
- CTs in the Right Direction

Failure of the above steps will result in incorrect power factor and kW calculations leading to problems load sharing if not corrected.

14.3 COMMUNICATIONS

- All Modules Connected on the MSC Link
- Re-Calibrate, Sync + Load Control, Multi-Set
- Remove One MSC Plug

Failure of the above steps will result in the controllers being unable to communicate leading to problems during synchronising and/or load sharing if not corrected.

14.4 SYNC CHECKS

- Use the Built in Sync Scope to Determine Correct Phase Wiring
- Phase Checks across the Breaker.

Failure of the above steps will result in serious damage to the system (breakers, bus bars, alternators, engines etc)

15 MAINTENANCE, SPARES, REPAIR AND SERVICING

The DSE8600 Series controller is *Fit and Forget*. As such, there are no user serviceable parts within the controller.

In the case of malfunction, you should contact your original equipment manufacturer (OEM).









15.1 PURCHASING ADDITIONAL CONNECTOR PLUGS FROM DSE

If you require additional plugs from DSE, please contact our Sales department using the part numbers below.

15.1.1 PACK OF PLUGS

Module type	Plug Pack Part Number
DSE8610	057-513

15.1.2 INDIVIDUAL PLUGS

8600 series terminal designation	Plug description	Part No.
1-13 	13 way 5.08mm	007-166
15-19 	5 way 5.08mm	007-445
22-38 	17 way 5.08mm	007-452
39-46 	8 way 7.62mm	007-454
47-50 	4 way 7.62mm	007-171
51-57 	7 way 5.08mm	007-447
60-70 	11 way 5.08mm	007-451
	PC Configuration interface lead (USB type A – USB type B)	016-125

 **NOTE:** Terminals 20, 21, 58 and 59 are not fitted to DSE8600 series controllers.

15.2 PURCHASING ADDITIONAL FIXING CLIPS FROM DSE

Item	Description	Part No.
	8600 series fixing clips (packet of 4)	020-294







15.3 PURCHASING ADDITIONAL SEALING GASKET FROM DSE

Item	Description	Part No.
	8600 series silicon sealing gasket	020-507

15.4 DSENET EXPANSION MODULES

NOTE: A maximum of twenty (20) expansion modules can be connected to the DSEnet®.

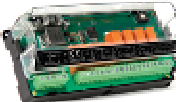
NOTE: DSEnet® utilises an RS485 connection. Using Belden 9841 (or equivalent) cable allows for the expansion cable to be extended to a maximum of 1.2km. DSE Stock and supply Belden 9841 cable. DSE Part Number 016-030.

Item	Max No. supported	Description	DSE Part numbers			
			Model order number	Sales literature	Operator manual	Installation Instructions
	4	Model DSE2130 expansion input module provides additional analogue and digital inputs for use with the DSE8600 series controller.	2130-001-00	055-060	057-082	053-033
	4	Model DSE2131 Ratio-metric input expansion module provides additional restive, digital, 0-10V and 4-20ma inputs for use with the controller.	2131-001-00	055-115	057-139	053-125
	4	Model DSE2133 RTD/Thermocouple input expansion module provides additional RTD and thermocouple inputs for use with the controller.	2133-001-00	055-114	057-140	053-126
	4	Model DSE2152 Ratio-metric output expansion module provides additional 0-10V and 4-20ma outputs for use with the controller.	2152-001-00	055-112	057-141	053-134
	10	Model DSE2157 expansion relay module provides eight additional voltage free relays for use with the DSE8600 series controller	2157-001-00	055-061	057-083	053-034
	10	Model DSE2548 expansion LED module provides additional LED indications, internal sounder and remote lamp test/alarm mute for use with the DSE8600 series controller.	2548-001-00	055-062	057-084	053-032

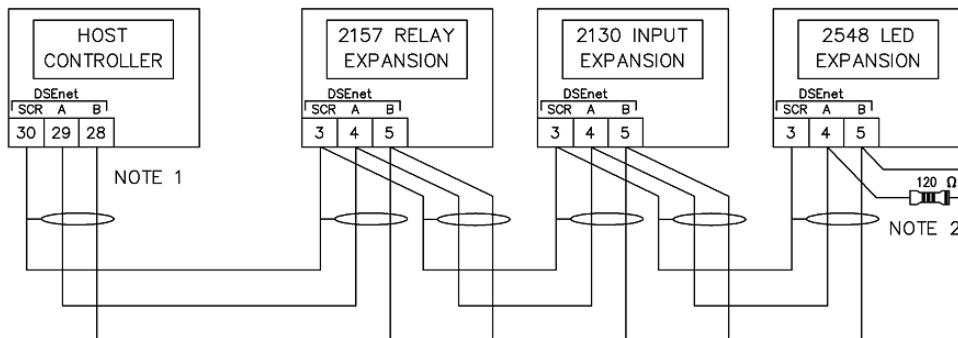

NOTE 1
AS A TERMINATING RESISTOR IS INTERNALLY FITTED TO THE HOST CONTROLLER, THE HOST CONTROLLER MUST BE THE FIRST UNIT ON THE DSEnet

NOTE 2
A 120 OHM TERMINATION RESISTOR MUST BE FITTED TO THE LAST UNIT ON THE DSEnet

16 WARRANTY

DSE provides limited warranty to the equipment purchaser at the point of sale. For full details of any applicable warranty, you are referred to your original equipment supplier (OEM).

17 DISPOSAL

17.1 WEEE (WASTE ELECTRICAL AND ELECTRONIC EQUIPMENT)

If you use electrical and electronic equipment you must store, collect, treat, recycle and dispose of WEEE separately from your other waste.



Intentionally Left Blank